

工程指示 / 要求簡箋(E.I.)

工程指示編號：EI/9366/18

修改版次：-

工程編號：J-836

工程名稱：日出康城7期

工程項目：WW2 鋁料模圖(19個)

收件人：Maggie

發件人：Pary

日期：16/05/2018

要求提供 / 確認 事項：

- | | | |
|------------------------------------|-------------------------------------|-------------------------------|
| <input type="checkbox"/> 初步鋁料 B.M. | <input type="checkbox"/> 加工拆圖，然後生產 | <input type="checkbox"/> 尺寸表 |
| <input type="checkbox"/> 正式鋁料 B.M. | <input type="checkbox"/> 技術上資料 / 指示 | <input type="checkbox"/> 報價 |
| <input type="checkbox"/> 配件 B.M. | <input type="checkbox"/> 樣辦或貨品說明書 | <input type="checkbox"/> 分判合約 |
| <input type="checkbox"/> 其他：_____ | | |

內容：

請開新模圖(X85516 - X85534)，共 19 個(WW2 用)

謝謝！！

請在 24 / 05 / 2018 前完成上列要求。

附：19 頁模圖，1頁

以上項目為：

- 原合約工程包 原合約工程加 / 減賬 新工程報價

原因：-

分發東莞各部門：

- () 生產技術總監 連附件 () 技術部 連附件 ^{永林} () 生產部 連附件 () 機械設計部 連附件
 () 採購部 連附件 () 生產統籌部 連附件
 () 質檢部 連附件 () 會計部 連附件 () 報關組 連附件 () 其他 楊榮輝 連附件

分發其他分判：() 王禮秋 連附件

分發香港各部門：

- () 行政部 連附件 () 會計部 連附件 () 統籌部 連附件 林哥 () 地盤科文 連附件
 () 採購部 連附件 () QS 部 連附件 () 維修部 連附件 () 其他 _____ 連附件

傳遞編號：

UK0845 / 18

發件人簽署：

項目經理簽署：

Ww 2

CUSTOMER	CUSTOMER APPROVAL	CUST PART NO. X85516
		SECTION NO.

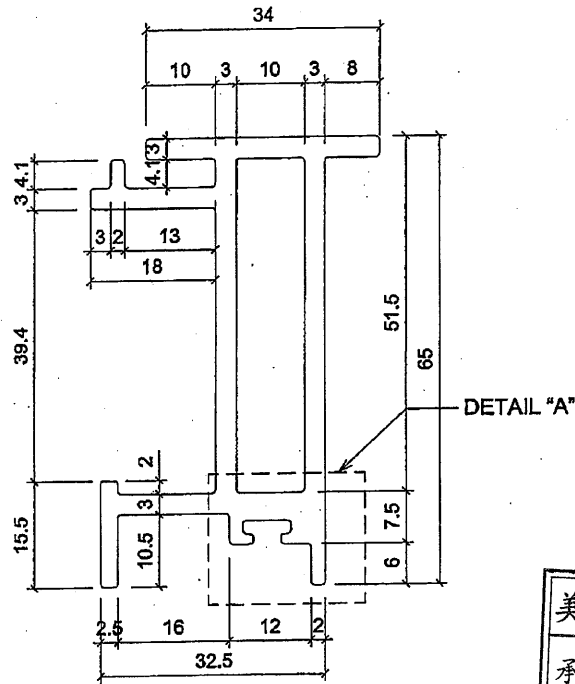

SF A
Sub Frame A

美特鋁質有限公司	
承認圖面	
日期	16/05/2018

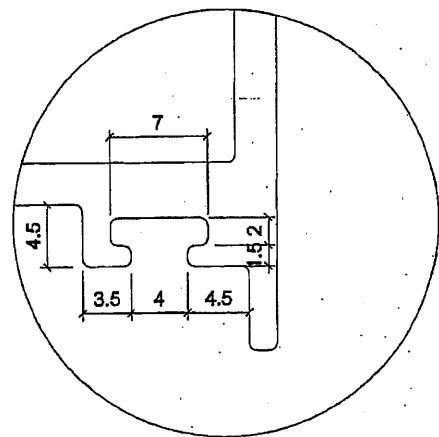
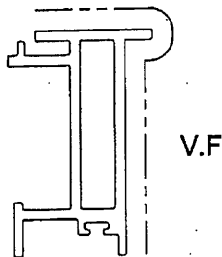

DETAIL "A" 2:1

SIGNATURE GRADEING	HIGH SIGNATURE GRADEING	C.C.DIA(MM)							
AREA (SQ MM)	638.95	UNSPECIFIED THICKNESS	3	PERIMETER (MM)	422.05	STANDARD		SCALE	1:1
MASS (KGM)	1.732	UNSPECIFIED CORNERS	R=0.5	SURFACE AREA	107	ALLOY	6063-T6	VERSION	
COMPANY ISSUE			DRAWA	Xan	DATE	18-04-26	APELLATION	PAGE OF	
			STANDA-RDIZATION		DATE		美特鋁質有限公司 MIDI Aluminium Fabricator Ltd.		
			TO SIGN		DATE				
			AUDITING		DATE				
MARKER	MODIFY	FILE NO	SIGNATURE	DATE	APPROV	DATE			

① A

CUSTOMER	CUSTOMER APPROVAL	CUST PART NO.	X85517
		SECTION NO.	

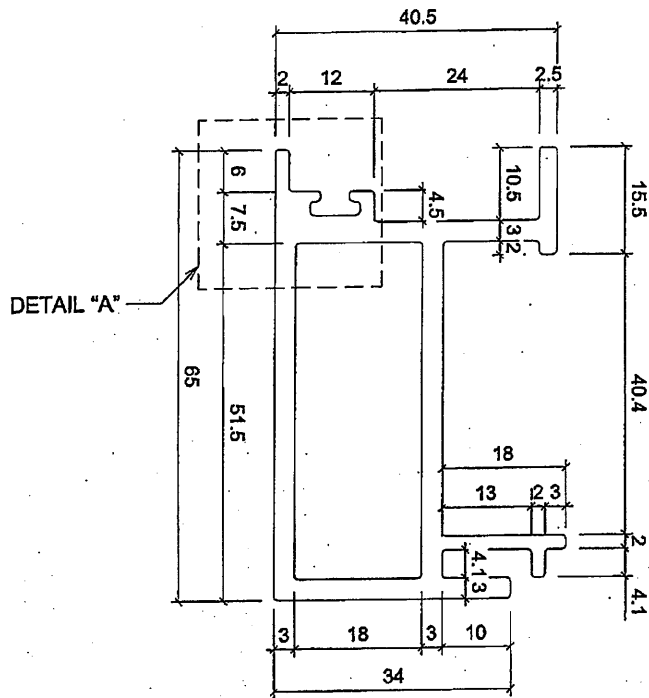

SFB
Spab FRONT
B

美特鋁質有限公司	
承認圖面	
日期	16/05/18

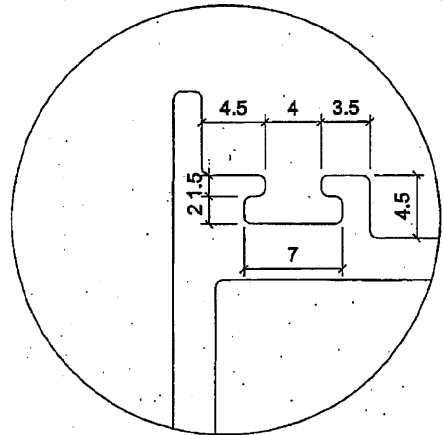
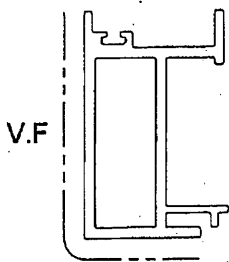

DETAIL "A" 2:1

SIGNATURE GRADEING	HIGH SIGNATURE GRADEING	C.C.DIA(MM)							
AREA (SQ MM)	644.95	UNSPECIFIED THICKNESS	3	PERIMETER (MM)	438.47	STANDARD	6063	SCALE	1:1
MASS (KGM)	1.748	UNSPECIFIED CORNERS	R=0.5	SURFACE AREA	99	ALLOY	6063-T6	VERSION	
COMPANY ISSUE			DRAWN	Xan	DATE	18-04-26	APPELLATION	PAGE OF	
			STANDARDIZATION		DATE				
			TO SIGN		DATE				
			AUDITING		DATE				
MARKER	MODIFY	FILE NO	SIGNATURE	DATE	APPROV				

美特鋁質有限公司
MIDI Aluminium Fabricator Ltd. 7

⑤ ②

CUSTOMER	CUSTOMER APPROVAL	CUST PART NO.	χ85518
		SECTION NO.	

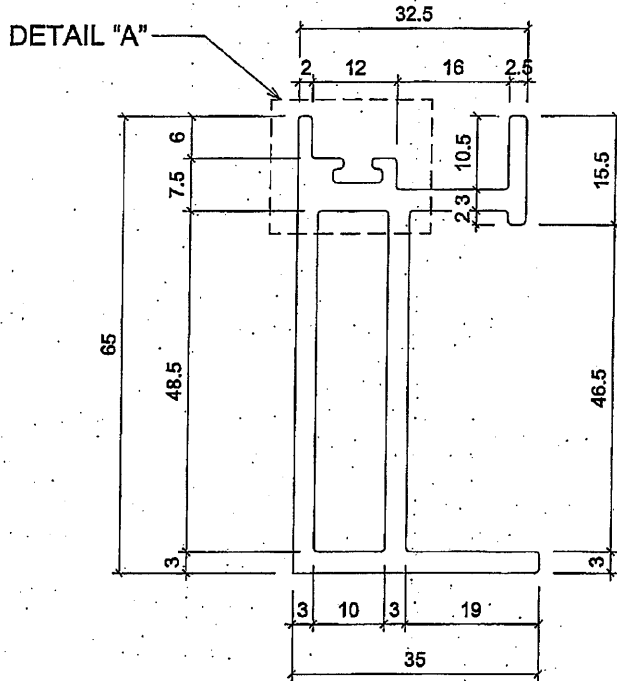

SFC

sub FRAME C

美特鋁質有限公司	
承認圖面	
日期	16.09.18

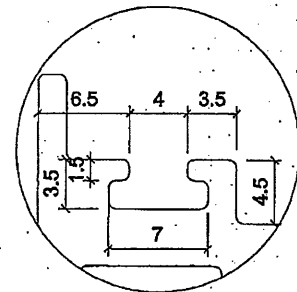
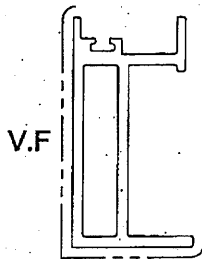

DETAIL "A" 2:1

SIGNATURE GRADEING	HIGH SIGNATURE GRADEING	C.C.DIA(MM)							
AREA (SQ MM)	579.8	UNSPECIFIED THICKNESS	3	PERIMETER (MM)	382.21	STANDARD		SCALE	1:1
MASS (KGM)	1.571	UNSPECIFIED CORNERS	R=0.5	SURFACE AREA	100.57	ALLOY	6063-T6	VERSION	
COMPANY ISSUE			DRAWN	Xan	DATE	18-04-26	APELLATION		PAGE OF
			STANDARDIZATION		DATE				
			TO SIGN		DATE				
			AUDITING		DATE				
MARKER	MODIFY	FILE NO	SIGNATURE	DATE	APPROV	DATE			

美特鋁質有限公司
MIDI Aluminium Fabricator Ltd.

③ ④

CUSTOMER	CUSTOMER APPROVAL	CUST PART NO.	X85519
		SECTION NO.	

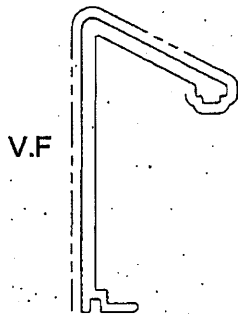
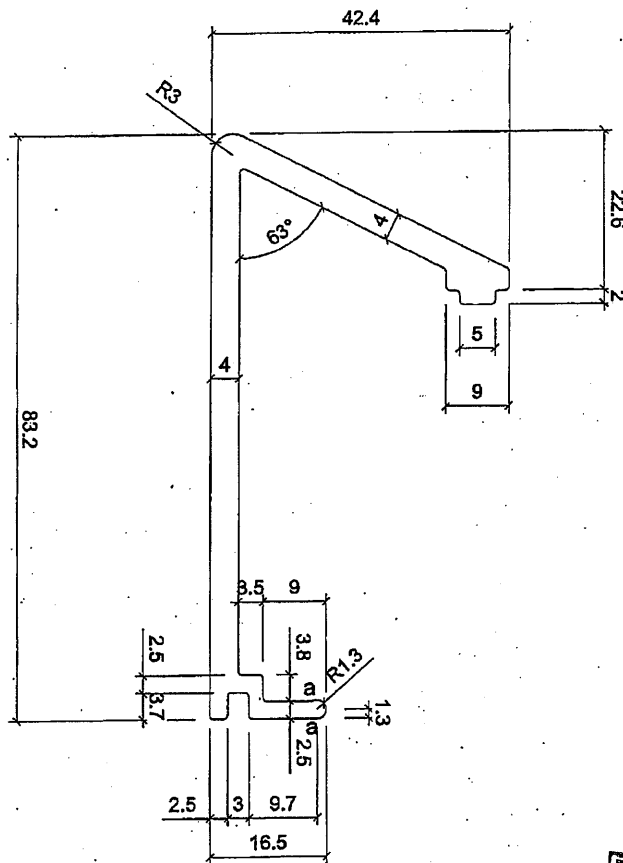

a=R 0.8

美特鋁質有限公司	
承認圖面	<i>[Signature]</i>
日期	16/05/18

SIGNATURE GRADEING	HIGH SIGNATURE GRADEING	C.C.DIA(MM)							
AREA (SQ MM)	553.19	UNSPECIFIED THICKNESS	4	PERIMETER (MM)	291.56	STANDARD	6063-T6	SCALE	1:1
MASS (KGM)	1.499	UNSPECIFIED CORNERS	R=0.5	SURFACE AREA	143	ALLOY	6063-T6	VERSION	
COMPANY ISSUE			DRAWN	Xan	DATE	18-04-26	APELLATION	PAGE OF	
			STANDARDIZATION		DATE		美特鋁質有限公司 MIDI Aluminium Fabricator Ltd.		
			TO SIGN		DATE				
			AUDITING		DATE				
MARKER	MODIFY	FILE NO	SIGNATURE	DATE	APPROV	DATE			

[Handwritten mark]

CUSTOMER	CUSTOMER APPROVAL	CUST PART NO.	X85521
		SECTION NO.	

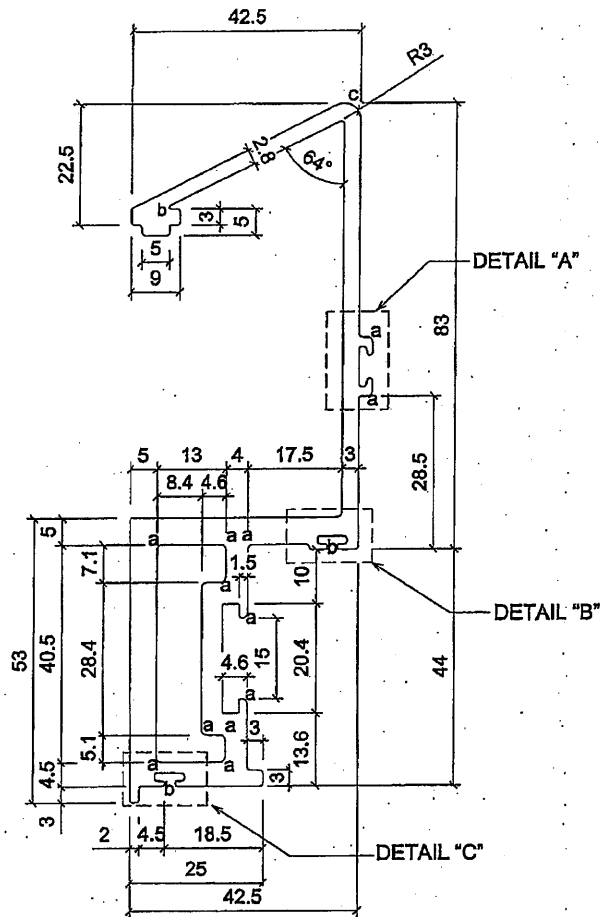

SASH
WINDOW
SKH

美特鋁質有限公司	
承認圖面	
日期	16/05/2018

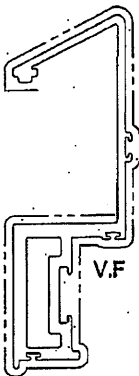
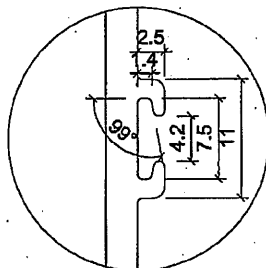
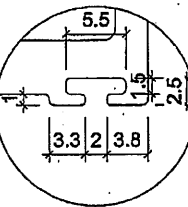
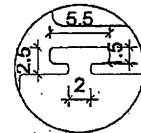

a=R 1

SIGNATURE GRADEING	HIGH SIGNATURE GRADEING	C.C.DIA(MM)							
AREA (SQ MM)	1119.55	UNSPECIFIED THICKNESS	5	PERIMETER (MM)	610.95	STANDARD		SCALE	1:1
MASS (KGM)	3.034	UNSPECIFIED CORNERS	R=0.5	SURFACE AREA	384.8	ALLOY	6063-T6	VERSION	
COMPANY ISSUE			DRAWA	Xan	DATE	18-04-26	APELLATION	PAGE OF	
			STANDA-RDIZATION		DATE				
			TO SIGN		DATE				
			AUDITING		DATE				
MARKER	MODIFY	FILE NO	SIGNATURE	DATE	APPROV				

美特鋁質有限公司
MDI Aluminium Fabricator Ltd.

6

CUSTOMER	CUSTOMER APPROVAL	CUST PART NO.	X85522
		SECTION NO.	

800 A
ADAPTER A

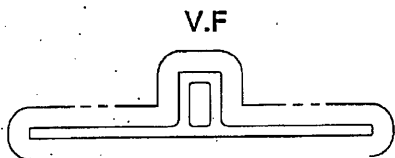
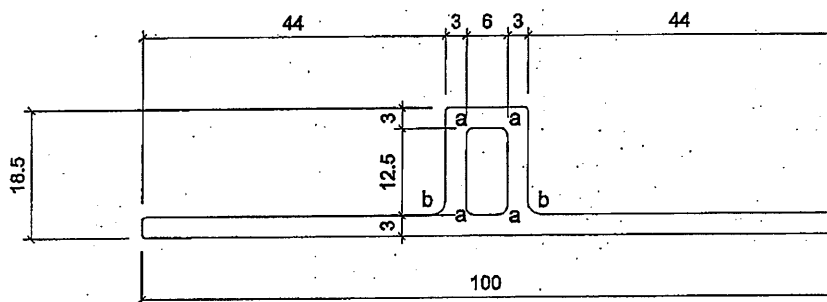

a=R 1
b=R 2

美特鋁質有限公司	
承認圖面	
日期	16/05/18

SIGNATURE GRADEING	HIGH SIGNATURE GRADEING	C.C.DIA(MM)						
AREA (SQ MM)	413.25	UNSPECIFIED THICKNESS	3	PERIMETER (MM)	269.28	STANDARD		SCALE 1:1
MASS (KGM)	1.12	UNSPECIFIED CORNERS	R=0.5	SURFACE AREA	135	ALLOY	6063-T6	VERSION
COMPANY ISSUE			DRAWN	Xan	DATE	18-04-26	APELLATION	PAGE OF
			STANDARDIZATION		DATE			
			TO SIGN		DATE			
			AUDITING		DATE			
MARKER	MODIFY	FILE NO	SIGNATURE	DATE	APPROV	DATE		

CUSTOMER	CUSTOMER APPROVAL	CUST PART NO.	X85823
		SECTION NO.	

76 PA
ADAPTED B

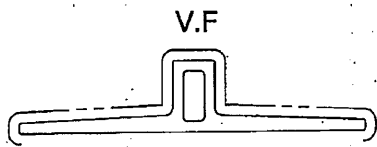
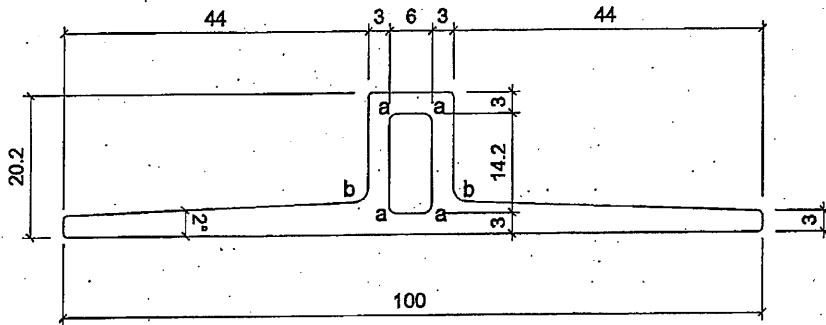

a = R 1
b = R 2

美特鋁質有限公司	
承認圖面	
日期	16/05/18

SIGNATURE GRADING	HIGH SIGNATURE GRADING	C.C.DIA(MM)							
AREA (SQ MM)	498.42	UNSPECIFIED THICKNESS	3	PERIMETER (MM)	272.94	STANDARD		SCALE	1:1
MASS (KGM)	1.35	UNSPECIFIED CORNERS	R=0.5	SURFACE AREA	135.25	ALLOY	6063-T6	VERSION	
COMPANY ISSUE			DRAWN	Xan	DATE	18-04-26	APPELLATION	PAGE OF	
			STANDARDIZATION		DATE		 美特鋁質有限公司 MIDI Aluminium Fabricator Ltd.		
			TO SIGN		DATE				
			AUDITING		DATE				
MARKER	MODIFY	FILE NO	SIGNATURE	DATE	APPROV	DATE			

8

CUSTOMER		CUSTOMER APPROVAL	CUST PART NO.	X85524
			SECTION NO.	

WJ A
ADAPTED C

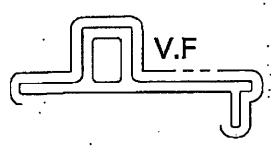
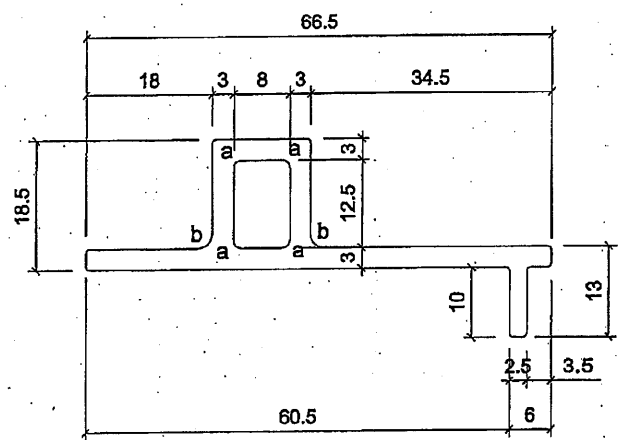

a=R1
b=R2

美特鋁質有限公司	
承認圖面	
日期	16/07/18

SIGNATURE GRADEING	HIGH SIGNATURE GRADEING	C.C.DIA(MM)							
AREA (SQ MM)	343.75	UNSPECIFIED THICKNESS	3	PERIMETER (MM)	225.42	STANDARD		SCALE	1:1
MASS (KGM)	0.932	UNSPECIFIED CORNERS	R=0.5	SURFACE AREA	114.6	ALLOY	6063-T6	VERSION	
COMPANY ISSUE			DRAWA	Xan	DATE	18-04-26	APPELLATION	PAGE OF	
			STANDA-RDIZATION		DATE				
			TO SIGN		DATE				
			AUDITING		DATE				
MARKER	MODIFY	FILE NO	SIGNATURE	DATE	APPROV		DATE		

9

CUSTOMER	CUSTOMER APPROVAL	CUST PART NO.	X85525
		SECTION NO.	

SC
FASD CAP

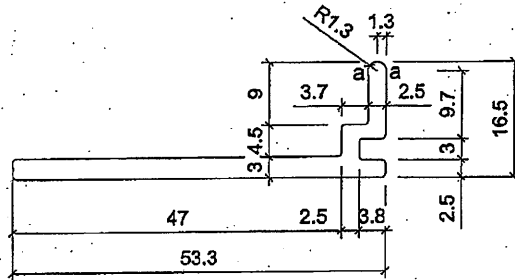

美特鋁質有限公司	
承認圖面	
日期	16/05/18

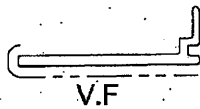

a=R 0.8

SIGNATURE GRADEING	HIGH SIGNATURE GRADEING	C.C.DIA(MM)							
AREA (SQ MM)	198.5	UNSPECIFIED THICKNESS	3	PERIMETER (MM)	143.89	STANDARD		SCALE	1:1
MASS (KGM)	0.538	UNSPECIFIED CORNERS	R=0.5	SURFACE AREA	55.82	ALLOY	6063-T6	VERSION	
COMPANY ISSUE			DRAWA	Xan	DATE	18-04-26	APPELLATION		PAGE OF
			STANDA-RDIZATION		DATE				
			TO SIGN		DATE				
			AUDITING		DATE				
MARKER	MODIFY	FILE NO	SIGNATURE	DATE	APPROV.				

美特鋁質有限公司
MIDI Aluminium Fabricator Ltd.

10

CUSTOMER	CUSTOMER APPROVAL	CUST PART NO.	X85526
		SECTION NO.	

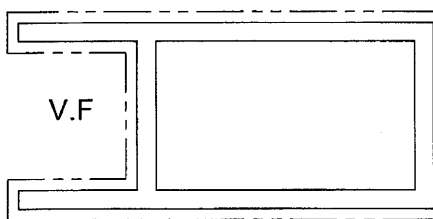
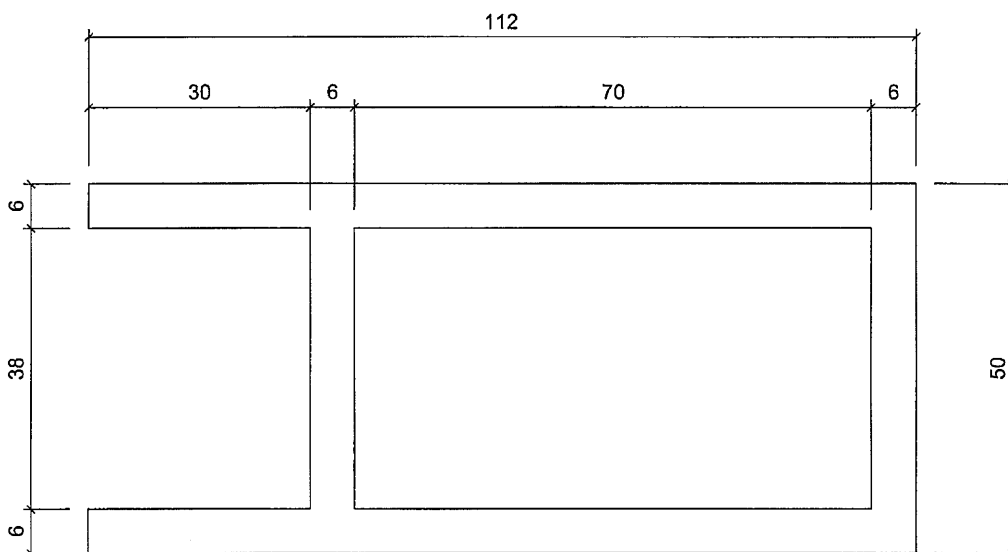

美特鋁質有限公司	
承認圖面	<i>[Signature]</i>
日期	16/05/18

6063-T5

SIGNATURE GRADE/ING	HIGH SIGNATURE GRADE/ING	C.C.DIA(MM)							
AREA (SQ MM)	1520	UNSPECIFIED THICKNESS	5	PERIMETER (MM)	608	STANDARD		SCALE	1:1
MASS (KGM)	4.119	UNSPECIFIED CORNERS	--	SURFACE AREA	338	ALLOY	6063-T6	VERSION	
COMPANY ISSUE			DRAWN	Xan	DATE	18-04-26	APPELLATION	-	PAGE OF
			STANDARDIZATION		DATE				
			TO SIGN		DATE				
			AUDITING		DATE				
MARKER	MODIFY	FILE NO	SIGNATURE	DATE	APPROV				
???? ???? (11)									

CUSTOMER	CUSTOMER APPROVAL	CUST PART NO.	X85528
		SECTION NO.	

CAPC
CAPPING B

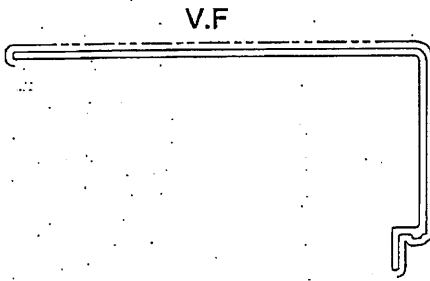
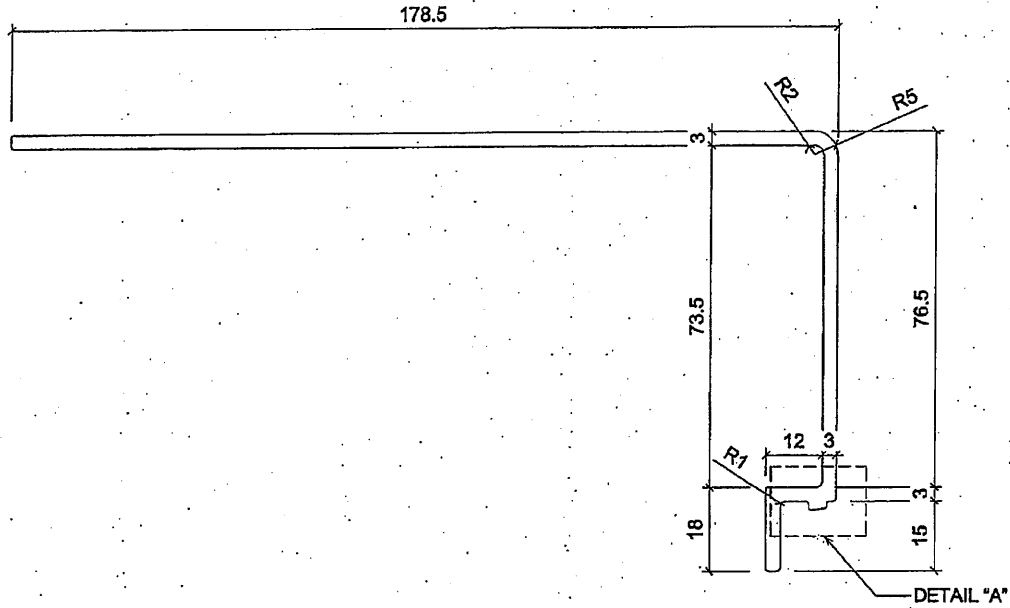

美特鋁質有限公司	
承認圖面	<i>[Signature]</i>
日期	16/05/18

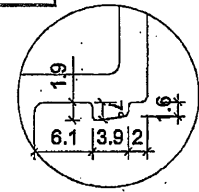

DETAIL "A" 2:1

6063-T5

SIGNATURE GRADEING	HIGH SIGNATURE GRADEING	C.C.DIA(MM)							
AREA (SQ MM)	848.42	UNSPECIFIED THICKNESS	3	PERIMETER (MM)	567.51	STANDARD		SCALE	1:1
MASS (KGM)	2.299	UNSPECIFIED CORNERS	R=0.5	SURFACE AREA	288.22	ALLOY	6063-T5	VERSION	
COMPANY ISSUE			DRAWN	Xan	DATE	18-04-26	APPELLATION	PAGE OF	
			STANDARDIZATION		DATE		美特鋁質有限公司 MIDI Aluminium Fabricator Ltd. B		
			TO SIGN		DATE				
			AUDITING		DATE				
MARKER	MODIFY	FILE NO	SIGNATURE	DATE	APPROV		DATE		

B

CUSTOMER	CUSTOMER APPROVAL	CUST PART NO.	X85529
		SECTION NO.	

OP TOP SF

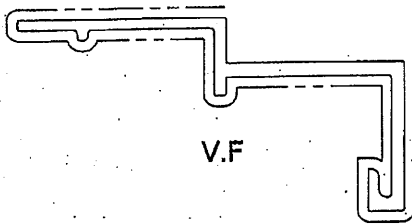
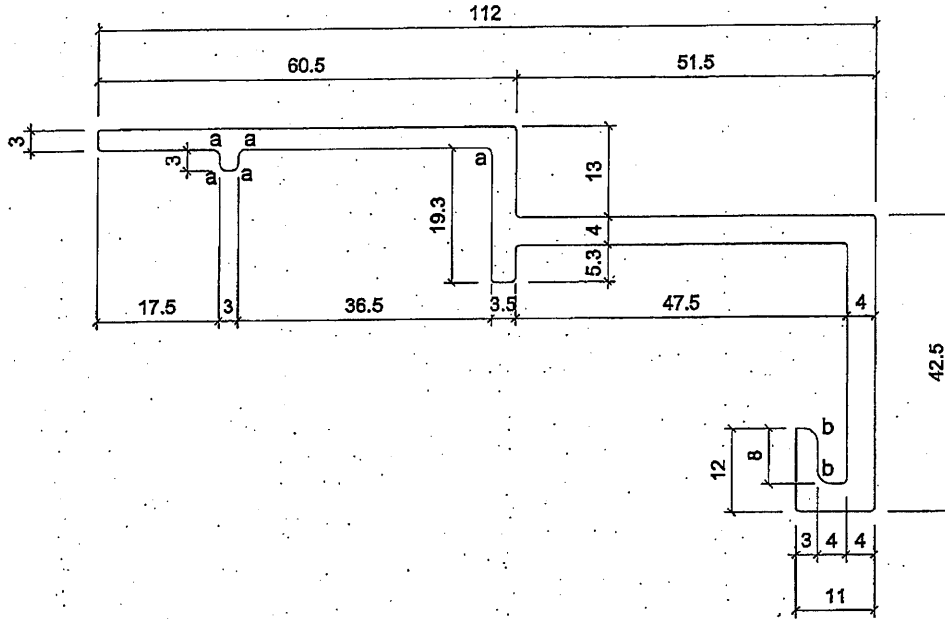

V.F

Open Window
sub FRAME

a = R1
b = R2

美特鋁質有限公司	
承認圖面	<i>[Signature]</i>
日期	16/05/18

SIGNATURE GRADEING	HIGH. SIGNATURE GRADEING	C.C.DIA(MM)							
AREA (SQ MM)	669.87	UNSPECIFIED THICKNESS		PERIMETER (MM)	375.06	STANDARD		SCALE	1:1
MASS (KGM)	1.815	UNSPECIFIED CORNERS	R=0.5	SURFACE AREA	268.72	ALLOY	6063-T6	VERSION	
COMPANY ISSUE			DRAWN	Xan	DATE	18-04-26	APPELLATION		PAGE OF
			STANDARDIZATION		DATE				
			TO SIGN		DATE				
			AUDITING		DATE				
MARKER	MODIFY	FILE NO	SIGNATURE	DATE	APPROV				

美特鋁質有限公司
MIDI Aluminium Fabricator Ltd. *[Signature]*

[Handwritten mark]

CUSTOMER	CUSTOMER APPROVAL	CUST PART NO.	X85530
		SECTION NO.	

open window sash (top)

TOP SASH

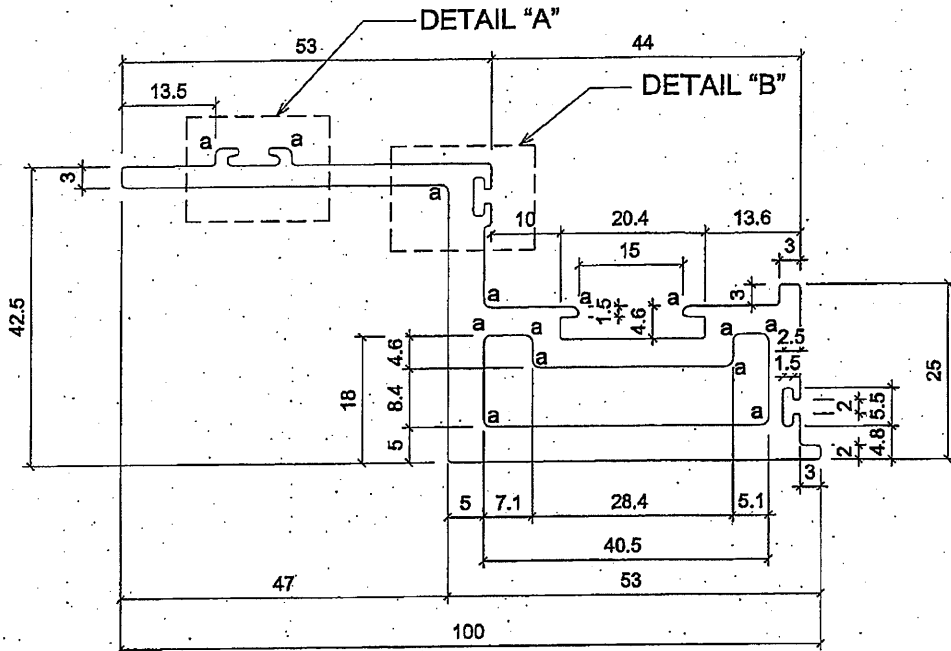

美特鋁質有限公司	
承認圖面	
日期	16/05/18

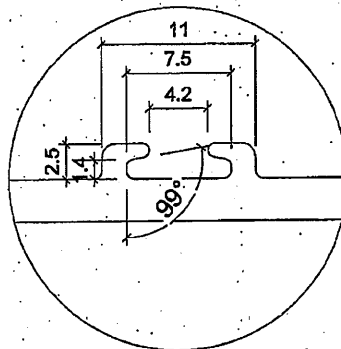

DETAIL "A" 2:1

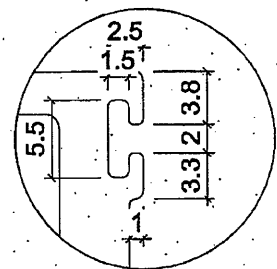

DETAIL "B" 2:1

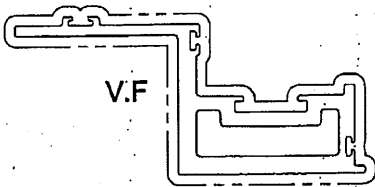

a=R1

SIGNATURE GRADEING	HIGH SIGNATURE GRADEING	C.C.DIA(MM)							
AREA (SQ MM)	878.13	UNSPECIFIED THICKNESS	5	PERIMETER (MM)	455.19	STANDARD		SCALE	1:1
MASS (KGM)	2.38	UNSPECIFIED CORNERS	R=0.5	SURFACE AREA	342.42	ALLOY	6063-T6	VERSION	
COMPANY ISSUE			DRAWN	Xan	DATE	18-04-26	APPELLATION		PAGE OF
			STANDARDIZATION		DATE				
			TO SIGN		DATE				
			AUDITING		DATE				
MARKER	MODIFY	FILE NO	SIGNATURE	DATE	APPROV				

美特鋁質有限公司
MDI Aluminium Fabricator Ltd.

15

CUSTOMER	CUSTOMER APPROVAL	CUST PART NO.	X85531
		SECTION NO.	

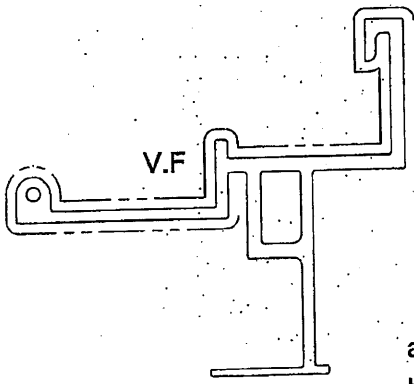
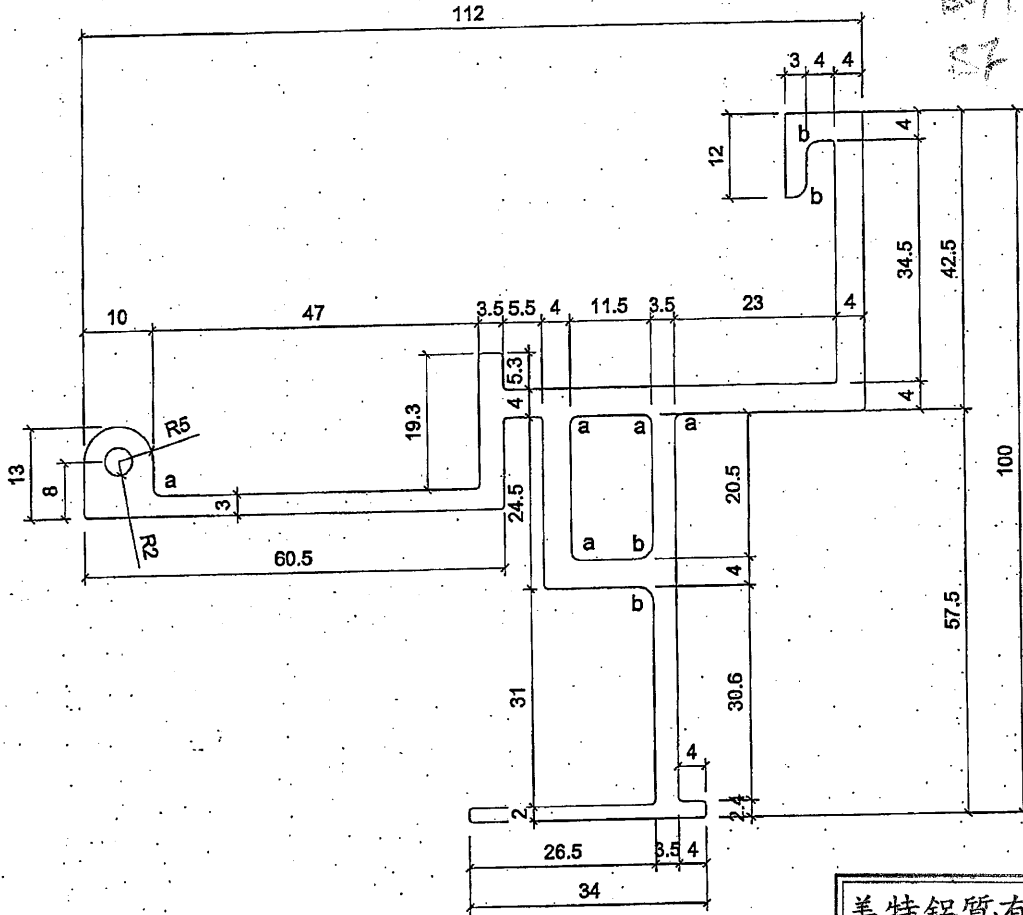

a=R 1
b=R 2

美特鋁質有限公司	
承認圖面	<i>[Signature]</i>
日期	16/05/18

OPEN WINDOW SILL
Bottom

SIGNATURE GRADEING	HIGH SIGNATURE GRADEING	C.C.DIA(MM)							
AREA (SQ MM)	1148	UNSPECIFIED THICKNESS	4	PERIMETER (MM)	633.9	STANDARD		SCALE	1:1
MASS (KGM)	3.111	UNSPECIFIED CORNERS	R=0.5	SURFACE AREA	280.92	ALLOY	6063-T6	VERSION	
COMPANY ISSUE			DRAWA	Xan	DATE	18-04-26	APPELLATION	PAGE OF	
			STANDARDIZATION		DATE				
			TO SIGN		DATE				
			AUDITING		DATE				
MARKER	MODIFY FILE NO	SIGNATURE	DATE	APPROV		DATE			

 美特鋁質有限公司
MIDI Aluminium Fabricator Ltd. 16

[Handwritten mark]

CUSTOMER	CUSTOMER APPROVAL	CUST PART NO.	X85533
		SECTION NO.	

PRESS BAR A

Pressure BAR
A

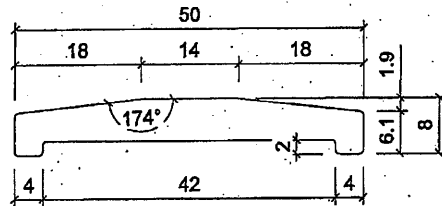

美特鋁質有限公司	
承認圖面	<i>[Signature]</i>
日期	16/05/18

SIGNATURE GRADEING	HIGH SIGNATURE GRADEING	C.C.DIA(MM)							
AREA (SQ MM)	279.93	UNSPECIFIED THICKNESS	3	PERIMETER (MM)	114.62	STANDARD	6063-T6	SCALE	1:1
MASS (KGM)	0.759	UNSPECIFIED CORNERS	R=0.5	SURFACE AREA		ALLOY	6063-T5	VERSION	
COMPANY ISSUE		DRAWA	Xan	DATE	18-04-26	APELLATION		PAGE OF	
		STANDA-RDIZATION		DATE					
		TO SIGN		DATE					
		AUDITING		DATE					
MARKER	MODIFY	FILE NO	SIGNATURE	DATE	APPROV				

[Handwritten mark]

CUSTOMER	CUSTOMER APPROVAL	CUST PART NO.	X85534
		SECTION NO.	

ST 1776NOR

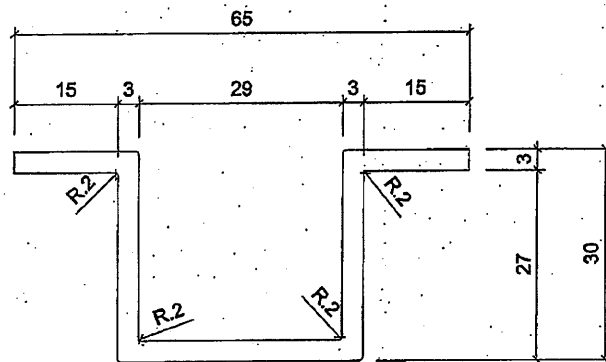

美特鋁質有限公司	
承認圖面	<i>[Signature]</i>
日期	16/05/18

6063-T6

SIGNATURE GRADEING	HIGH SIGNATURE GRADEING	C.C.DIA(MM)							
AREA (SQ MM)	356.82	UNSPECIFIED THICKNESS	3	PERIMETER (MM)	242.8	STANDARD		SCALE	1:1
MASS (KGM)	0.967	UNSPECIFIED CORNERS	R=0.5	SURFACE AREA		ALLOY	6063-T5	VERSION	
COMPANY ISSUE		DRAWN	Xan	DATE	18-04-26	APPELLATION		PAGE OF	
		STANDARDIZATION		DATE					
		TO SIGN		DATE					
		AUDITING		DATE					
MARKER	MODIFY	FILE NO	SIGNATURE	DATE	APPROV				

[Handwritten mark]

日出康城7期 WW2 Die drawing table

Item	Grade	DIE NO.	BD NO.	位置	EI			
1	6063-T6	X85516		WW2	1			
2	6063-T5	X85517		WW2	1			
3	6063-T6	X85518		WW2	1			
4	6063-T5	X85519		WW2	1			
5	6063-T6	X85520		WW2	1			
6	6063-T6	X85521		WW2	1			
7	6063-T6	X85522		WW2	1			
8	6063-T6	X85523		WW2	1			
9	6063-T6	X85524		WW2	1			
10	6063-T6	X85525		WW2	1			
11	6063-T5	X85526		WW2	1			
12	6063-T5	X85527		WW2	1			
13	6063-T5	X85528		WW2	1			
14	6063-T6	X85529		WW2	1			
15	6063-T6	X85530		WW2	1			
16	6063-T6	X85531		WW2	1			
17	6063-T6	X85532		WW2	1			
18	6063-T5	X85533		WW2	1			
19	6063-T6	X85534		WW2	1			