



工程指示 / 要求簡箋(E.I.)

工程指示編號：EI / 1707 / 20 修改版次：

工程編號：J-836

工程名稱：日出康城7期 平台

工程項目：Window Wall(WW4) 上台雲石底鋁角 (後加)

收件人：生統

發件人：大明

日期：20/04/2020

要求提供 / 確認 事項：

- | | | |
|------------------------------------|-------------------------------------|-------------------------------|
| <input type="checkbox"/> 初步鋁料 B.M. | <input type="checkbox"/> 加工拆圖，然後生產 | <input type="checkbox"/> 尺寸表 |
| <input type="checkbox"/> 正式鋁料 B.M. | <input type="checkbox"/> 技術上資料 / 指示 | <input type="checkbox"/> 報價 |
| <input type="checkbox"/> 配件 B.M. | <input type="checkbox"/> 樣辦或貨品說明書 | <input type="checkbox"/> 分判合約 |
| <input type="checkbox"/> 其他：_____ | | |

內容：

煩請按圖紙生產鋁角後 送地盤安裝。 (共 99 件)
(可用倉儲料界成)

CI-MCA-A-173

請在 ~~11/04/2020~~ 前完成上列要求。

11/05/2020

附有關圖紙 / 文件：BM 表 頁,圖紙 48 頁

以上項目為:

- 原合約工程包 原合約工程加 / 減賬 新工程報價

原因：-

分發東莞各部門：

- ()生產技術總監 連附件 ()技術部 連附件 ()生產部 連附件 ()機械設計部 連附件
 ()採購部 連附件 (✓)生產統籌部 連附件 車梅
 ()質檢部 連附件 ()會計部 連附件 ()報關組 連附件 ()其他 _____ 連附件

分發香港各部門：

- ()行政部 連附件 ()會計部 連附件 ()統籌部 連附件 (✓)工程部地盤科文 連附件 彭精奇
 ()採購部 連附件 ()QS 部 連附件 ()維修部 連附件 ()其他 _____ 連附件

傳遞編號：

Hk 0628

FTP

發件人簽署：

項目經理簽署：

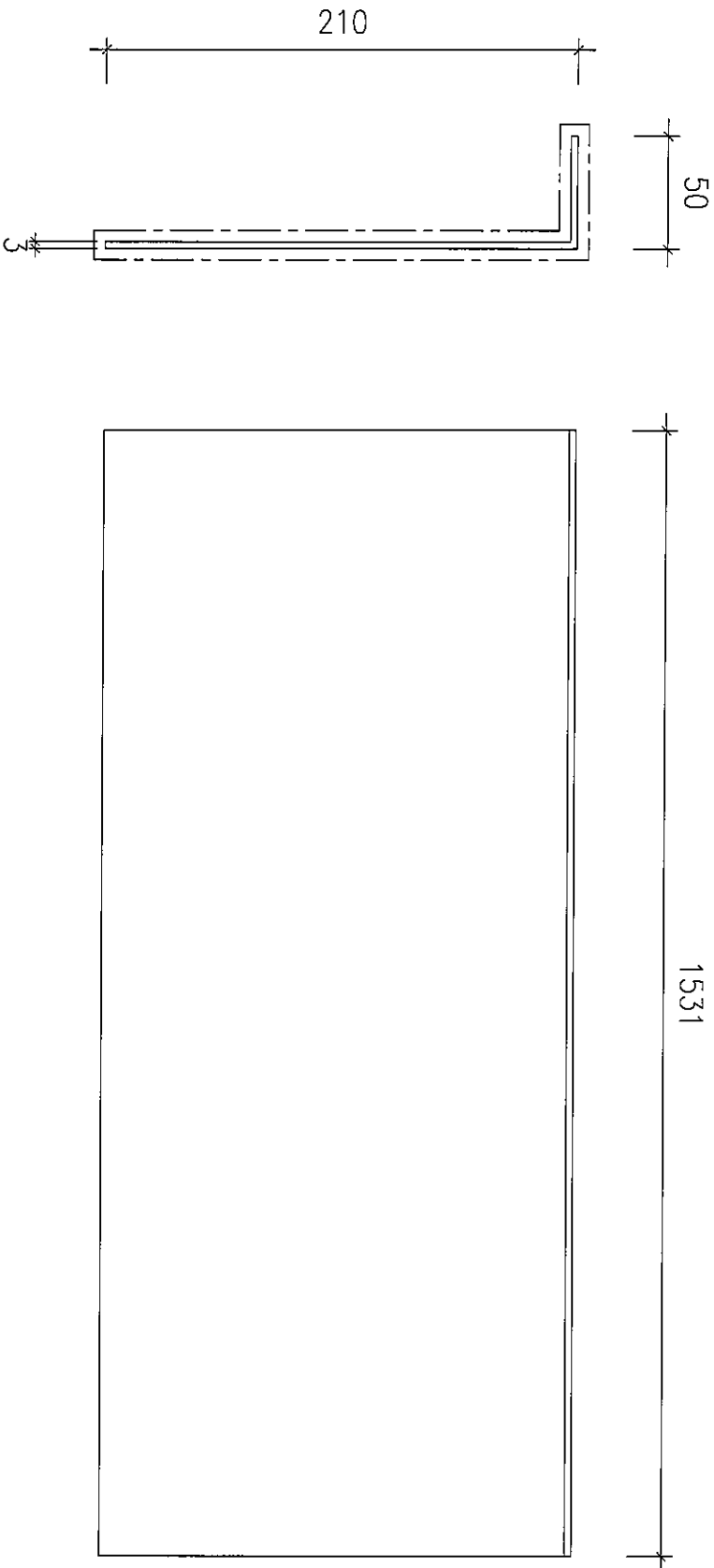

J836-AA-201

50X210X3mm 厚鋁角

顏色：TUC51602XL(RY)-3 深灰色

數量 共 4 件

①

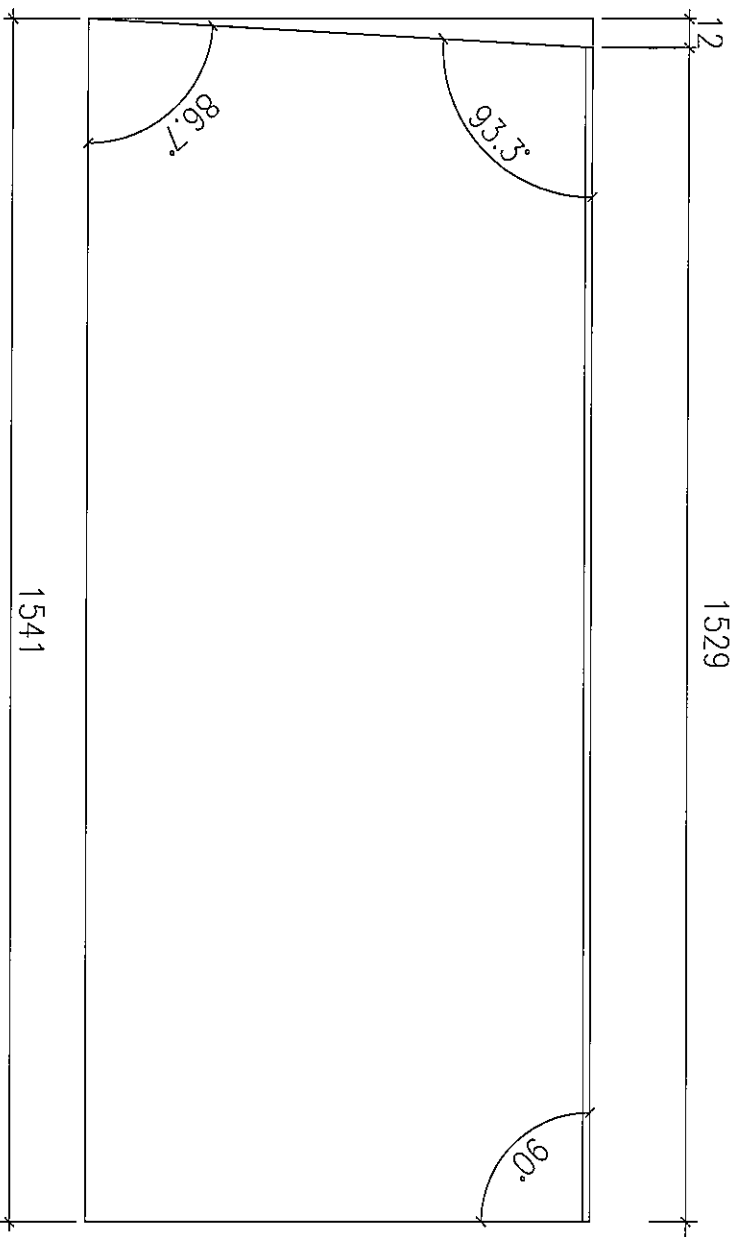
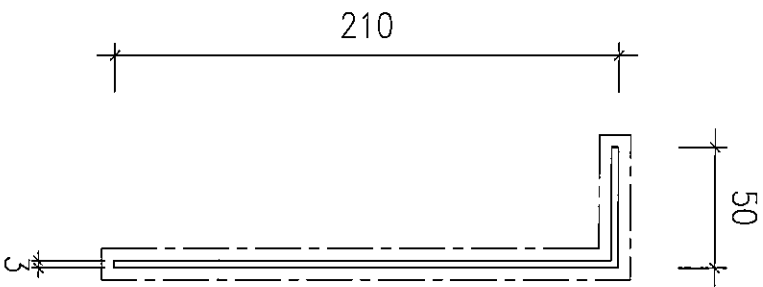

J836-AA-202

50X210X3mm 厚鋁角

顏色：TUC51602XL(RY)-3 深灰色

數量 共 1 件

⑤

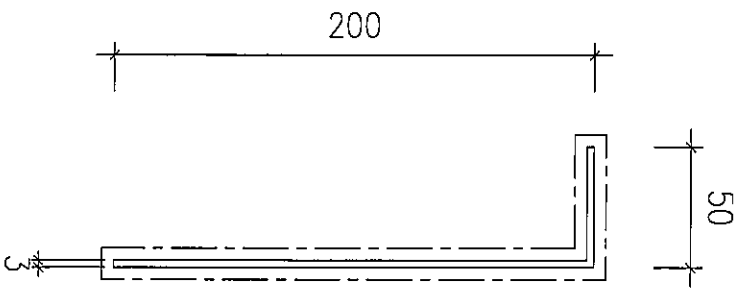

J836-AA-301-1	長度 = 1850	共 8	支
J836-AA-301-2	長度 = 1300	共 1	支
J836-AA-301-3	長度 = 850	共 1	支
		共 10	支

J836-AA-301

50X200X3mm 厚鋁角

顏色：TUC51602XL(RY)-3 深灰色

數量 共 件

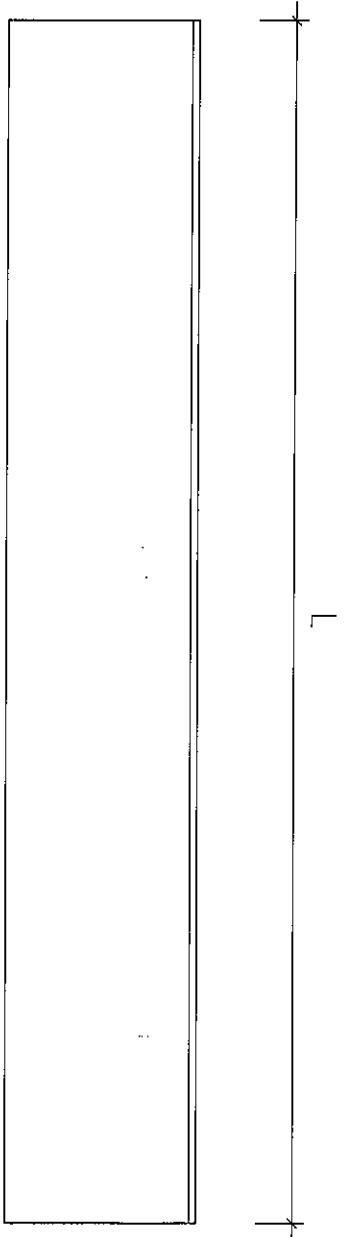
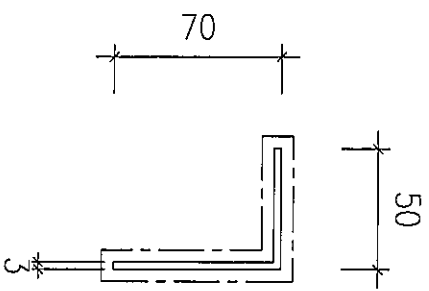

J836-AA-302-1	長度 = 1367	共 1	支
J836-AA-302-2	長度 = 522	共 1	支
J836-AA-302-3	長度 = 1795	共 5	支
J836-AA-302-4	長度 = 1788	共 1	支
J836-AA-302-5	長度 = 160	共 1	支
J836-AA-302-6	長度 = 1408	共 1	支
J836-AA-302-7	長度 = 1870	共 1	支
J836-AA-302-8	長度 = 1491	共 1	支
		共 12	支

J836-AA-302

50X70X3mm 厚鋁角

顏色：TUC51602XL(RY)-3 深灰色

數量 共 件

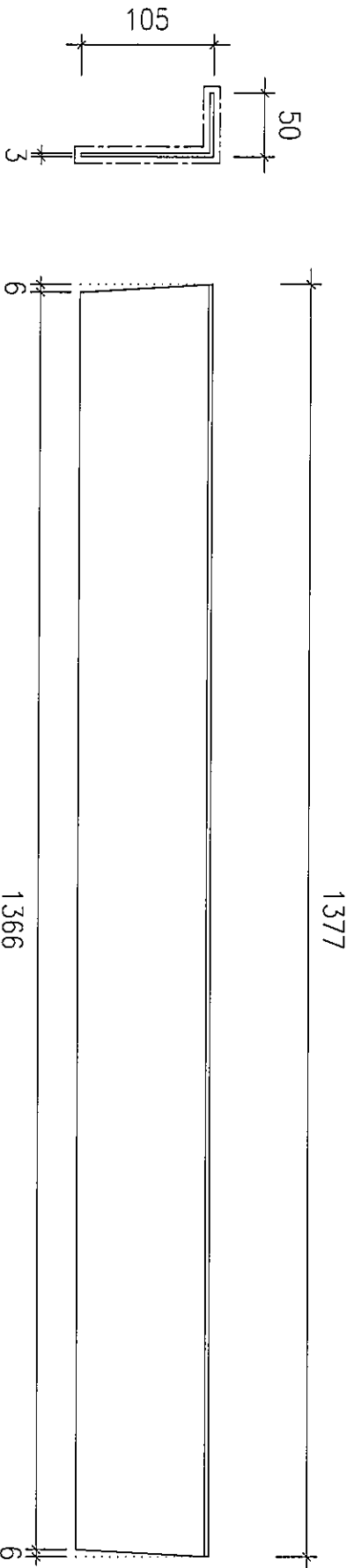

J836-AA-401

50x105x3mm 厚鋁角

顏色：TUC51602XL(RY)-3 深灰色

數量 共 1 件

5

⊗

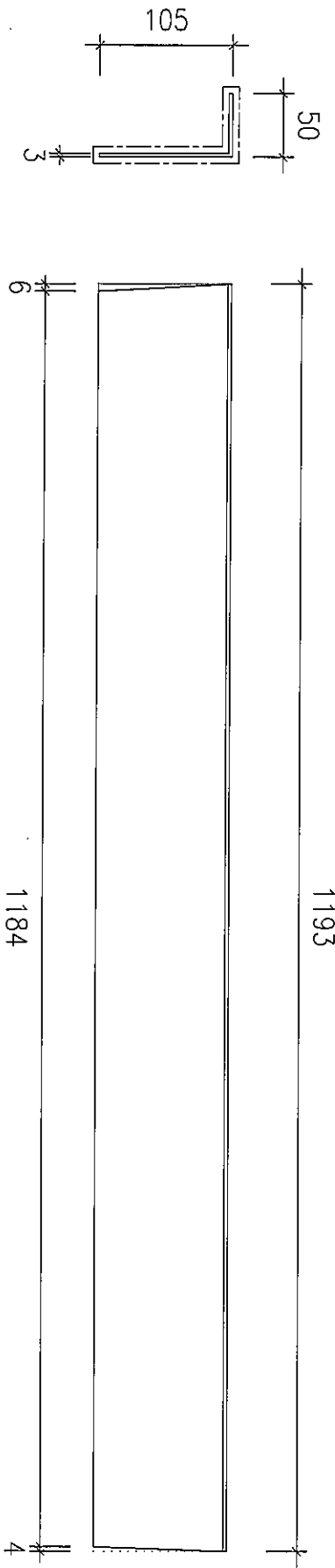

J836-AA-402
50X105X3mm 厚鋁角
顏色：TUC51602XL(RY)-3 深灰色
數量共 1件

①
②

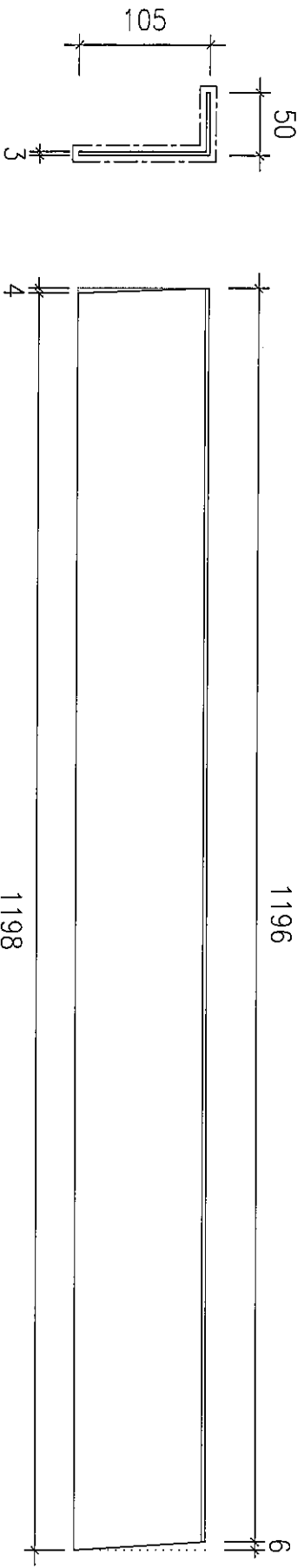

J836-AA-403
50X105X3mm 厚鋁角
顏色：TUC51602XL(RY)-3 深灰色
數量共 1件

⑦
⑧

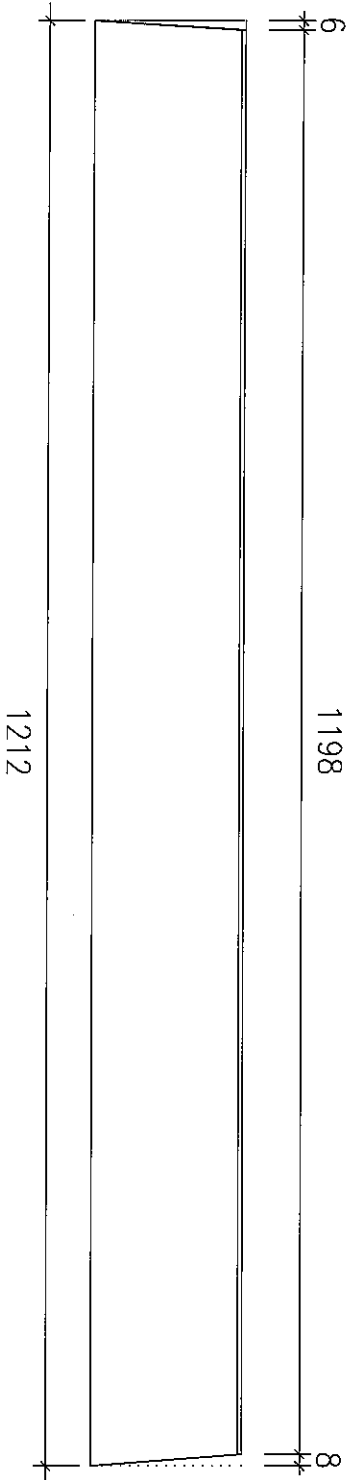
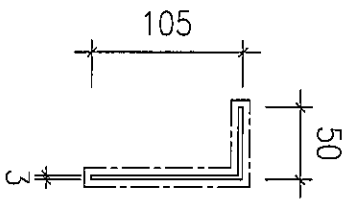

J836-AA-404
50x105x3mm 厚鋁角
顏色：TUC51602XL(RY)-3 深灰色
數量 共 1 件



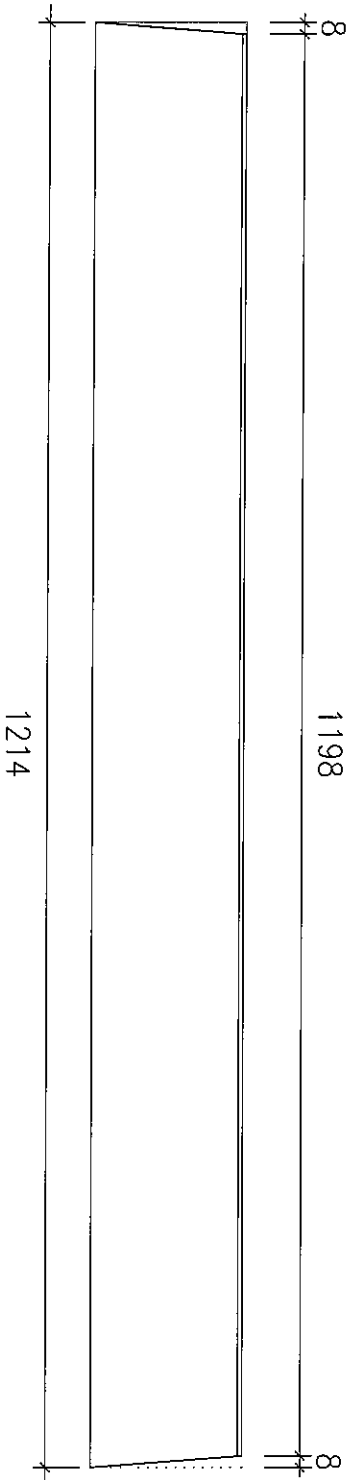
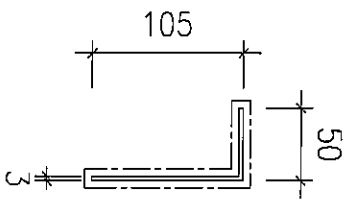

J836-AA-405
50x105x3mm 厚鋁角
顏色：TUC51602XL(RY)-3 深灰色
數量共 1 件



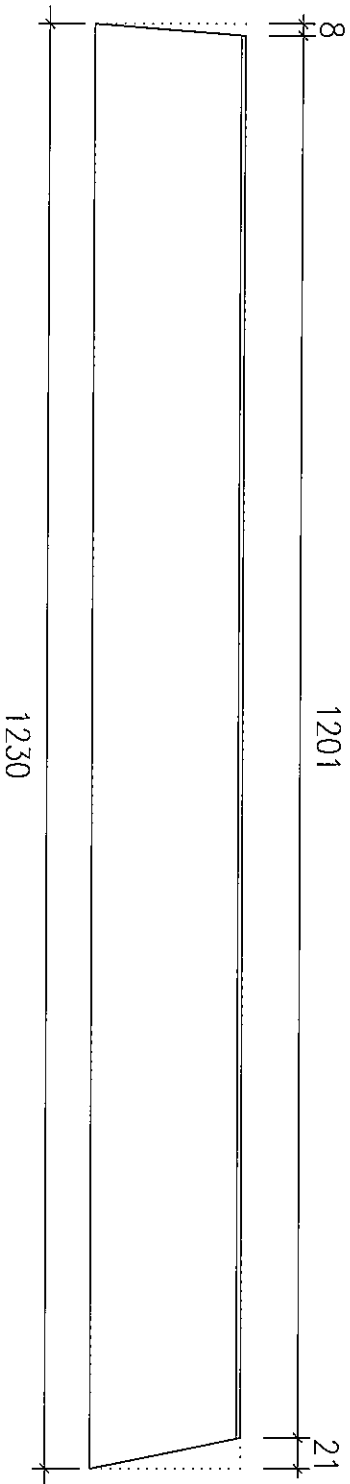
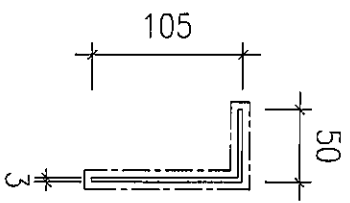

J836-AA-406
50x105x3mm 厚鋁角
顏色：TUC51602XL(RY)-3 深灰色
數量共 1件



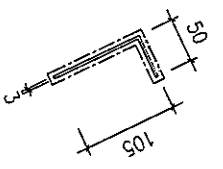
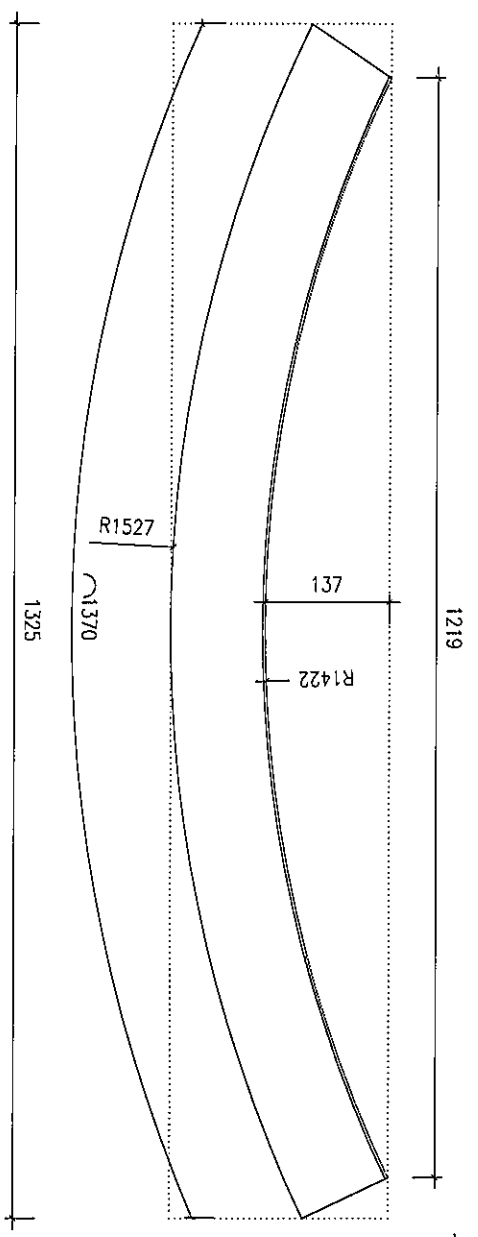
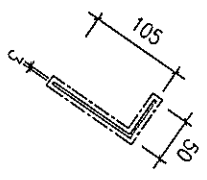

J836-AA-407
50x105x3mm 厚鋁角
顏色：TUC51602XL(RY)-3 深灰色
數量共 1 件

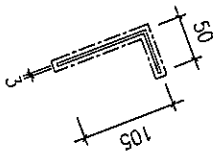
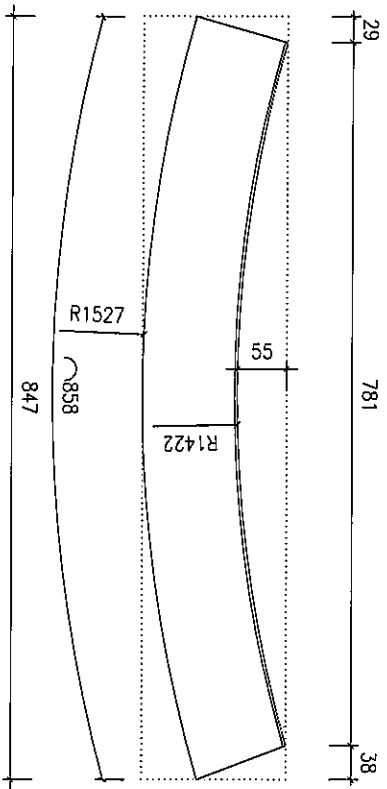
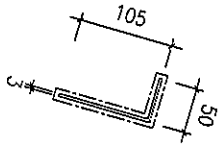

J836-AA-408
50x105x3mm 厚鋁角
顏色：TUC51602XL(RY)-3 深灰色
數量 共 1 件

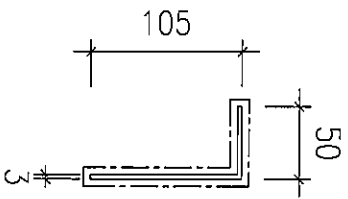

1046

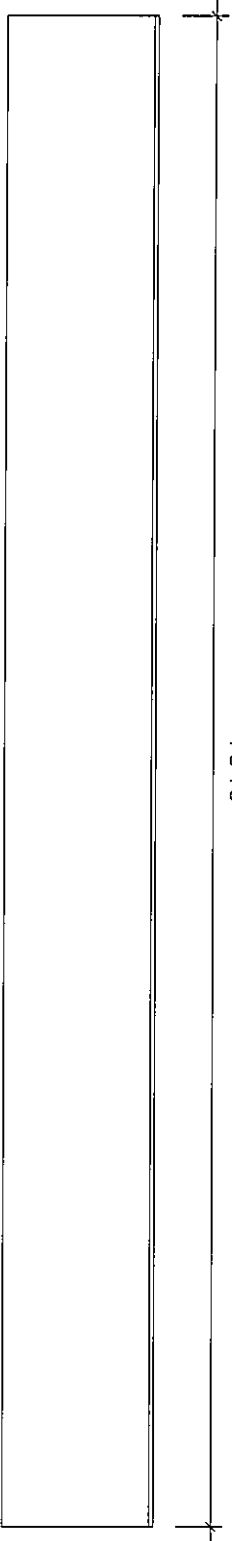

J836-AA-409
50x105x3mm 厚鋁角
顏色：TUC51602XL(RY)-3 深灰色
數量 共 1 件

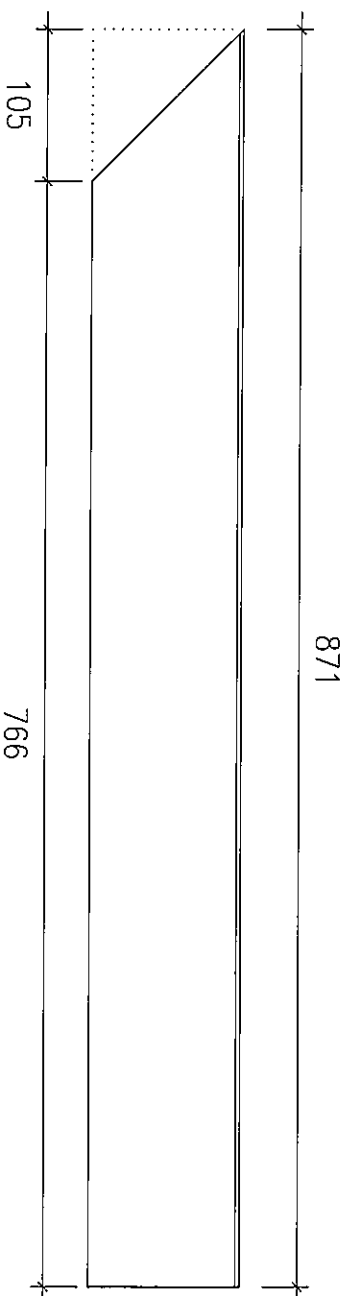
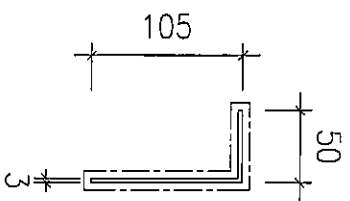

J836-AA-411
50x105x3mm 厚鋁角
顏色：TUC51602XL(RY)-3 深灰色
數量共 1 件

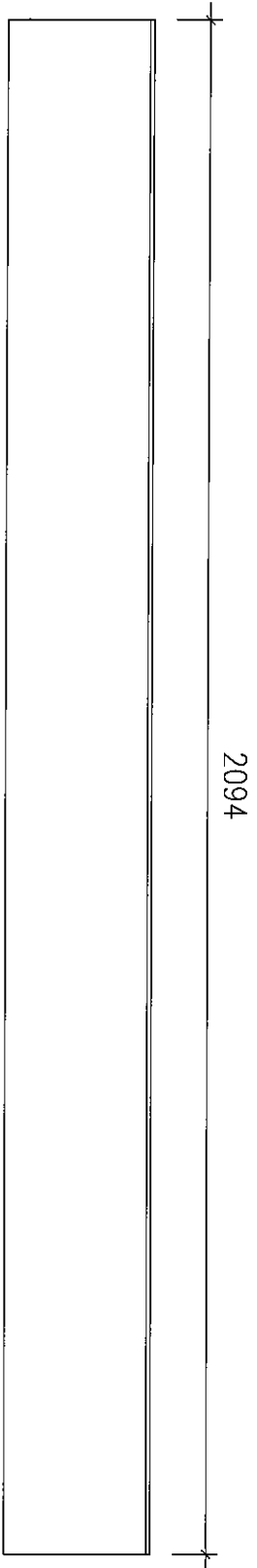
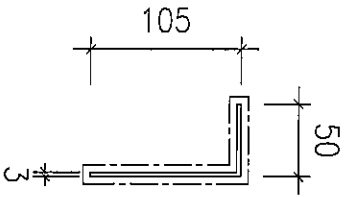

J836-AA-412
50x105x3mm 厚鋁角
顏色：TUC51602XL(RY)-3 深灰色
數量 共 2 件

18

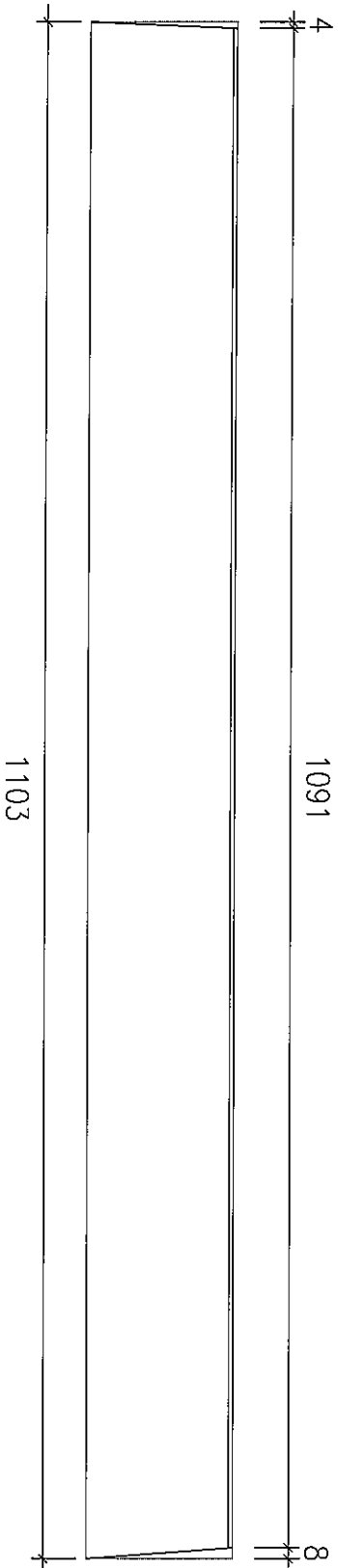
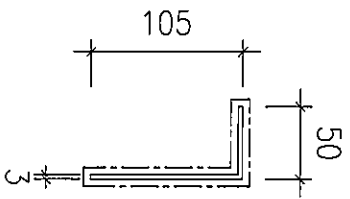

J836-AA-413
50x105x3mm 厚鋁角
顏色：TUC51602XL(RY)-3 深灰色
數量 共 1 件

17

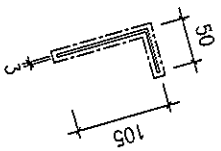
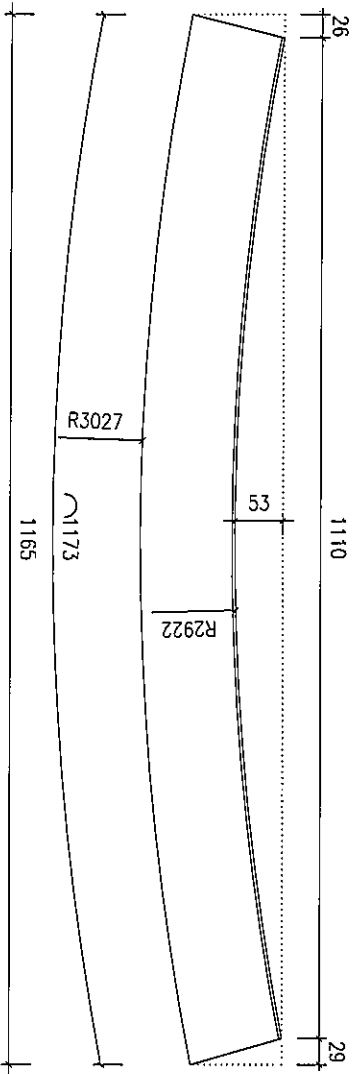
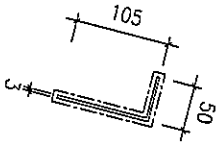

J836-AA-414
50x105x3mm 厚鋁角
顏色：TUC51602XL(RY)-3 深灰色
數量共 1 件

18

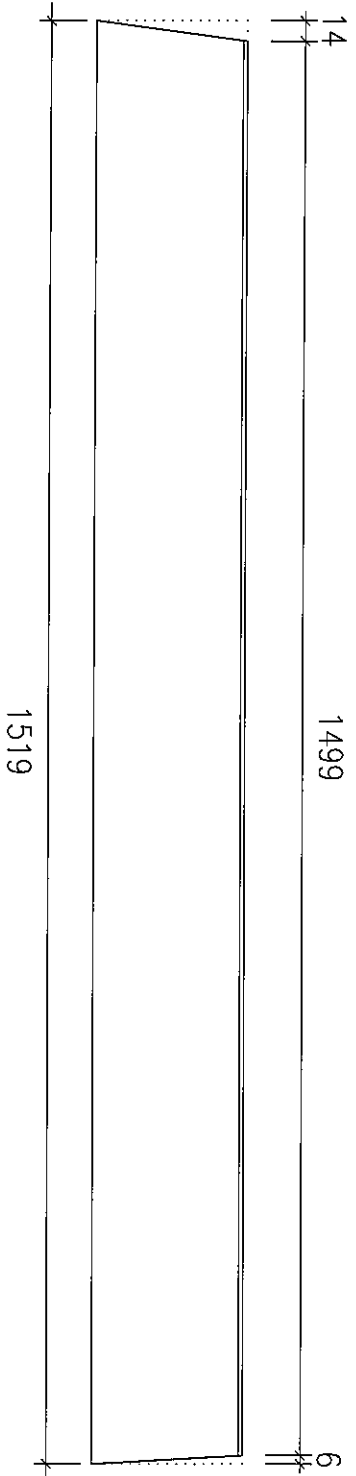
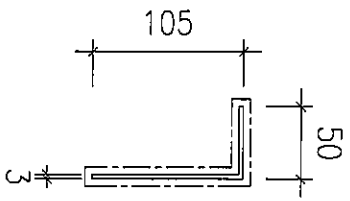

J836-AA-415
50x105x3mm 厚鋁角
顏色：TUC51602XL(RY)-3 深灰色
數量共 1件

19

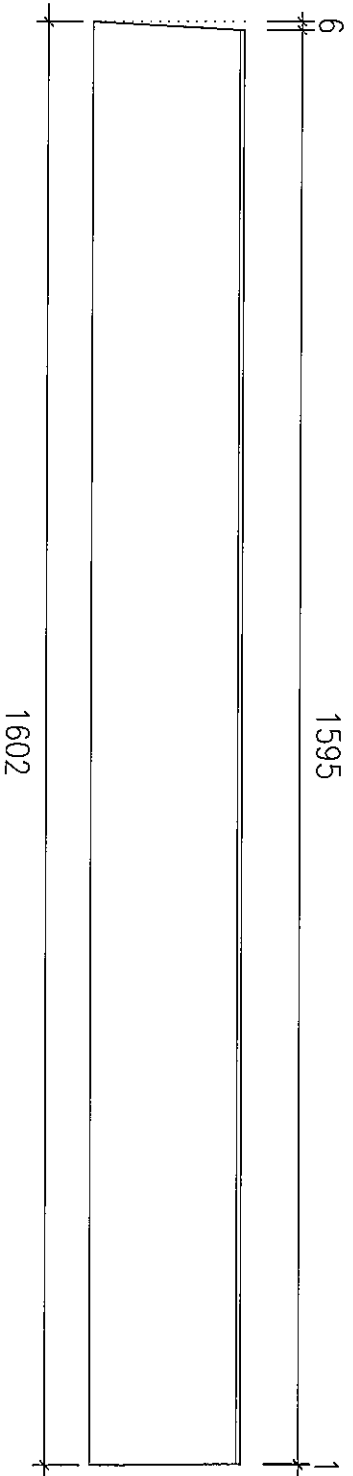
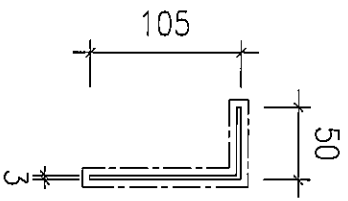

J836-AA-416
50x105x3mm 厚鋁角
顏色：TUC51602XL(RY)-3 深灰色
數量 共 1 件

28

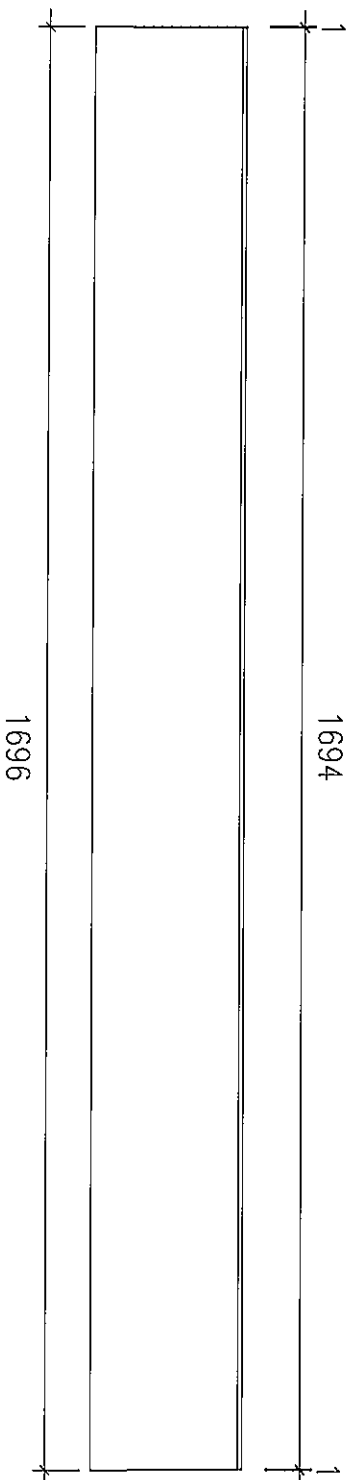
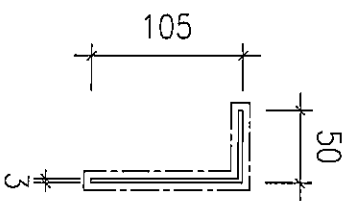

J836-AA-417
50x105x3mm 厚鋁角
顏色：TUC51602XL(RY)-3 深灰色
數量共 1件

217

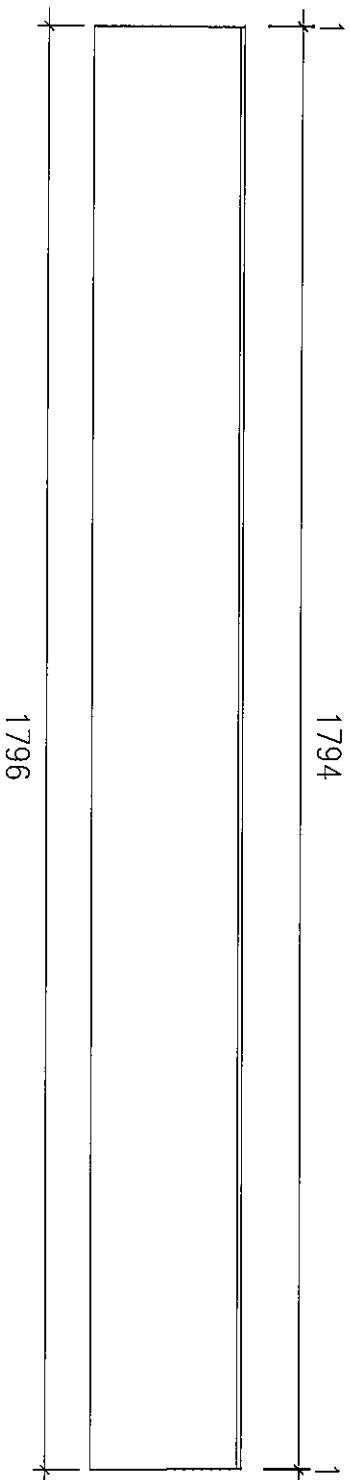
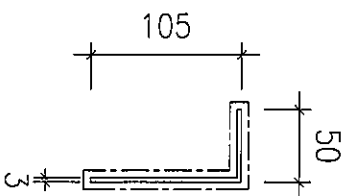

J836-AA-418
50x105x3mm 厚鋁角
顏色：TUC51602XL(RY)-3 深灰色
數量共 10 件

22

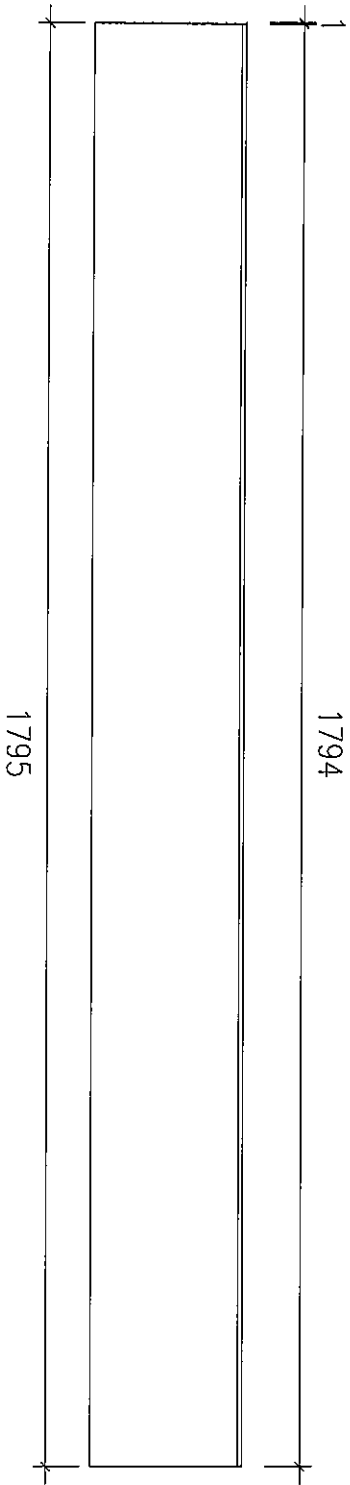
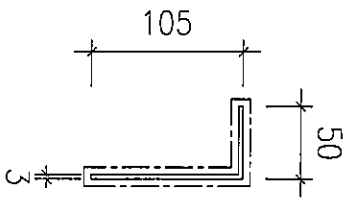

J836-AA-419
50x105x3mm 厚鋁角
顏色：TUC51602XL(RY)-3 深灰色
數量共 1 件

23

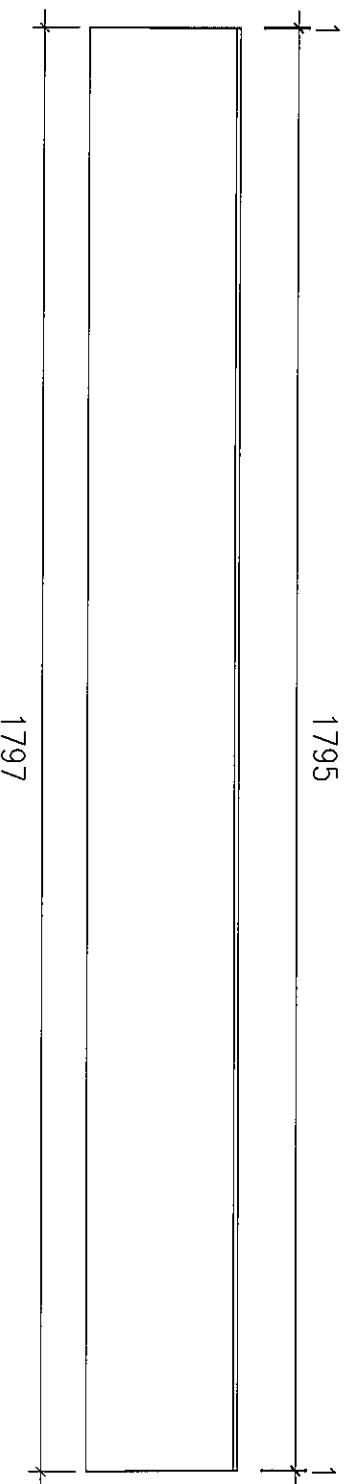
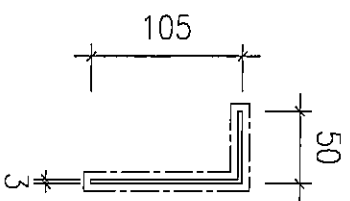

J836-AA-420
50X105X3mm 厚鋁角
顏色：TUC51602XL(RY)-3 深灰色
數量 共 6 件

24

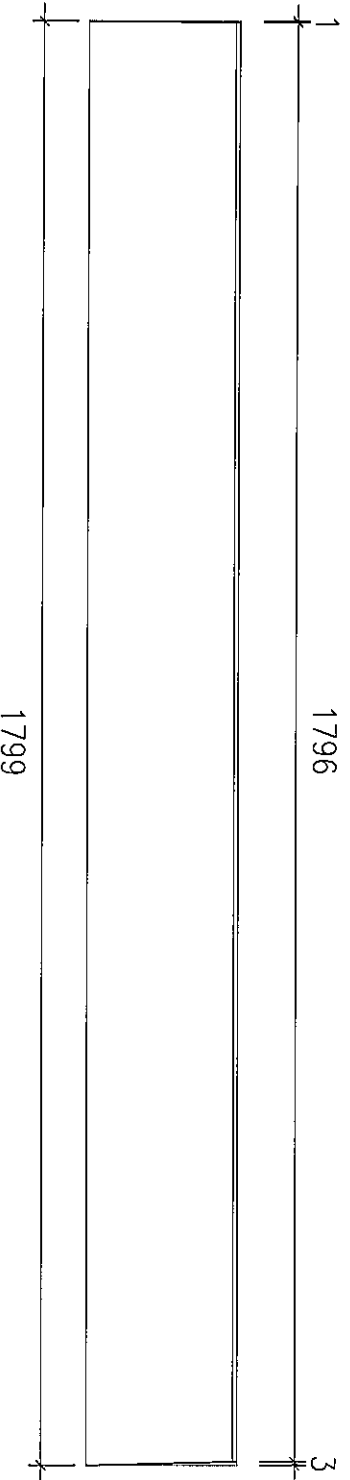
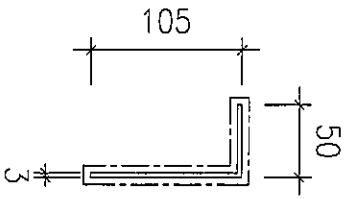

J836-AA-421
50X105X3mm 厚鋁角
顏色：TUC51602XL(RY)-3 深灰色
數量共 1 件

25

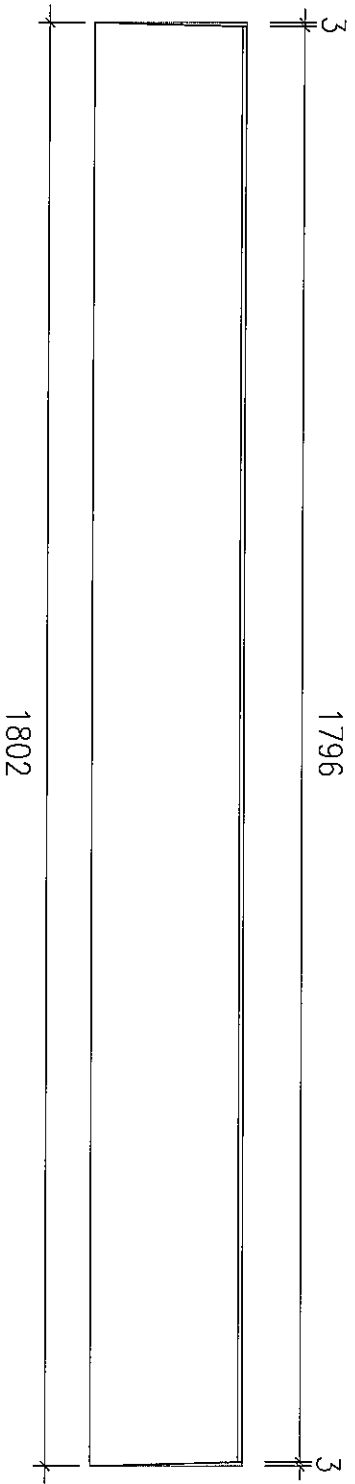
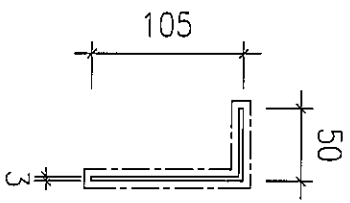

J836-AA-422
50X105X3mm 厚鋁角
顏色：TUC51602XL(RY)-3 深灰色
數量共 5 件

28

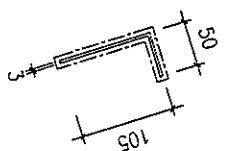
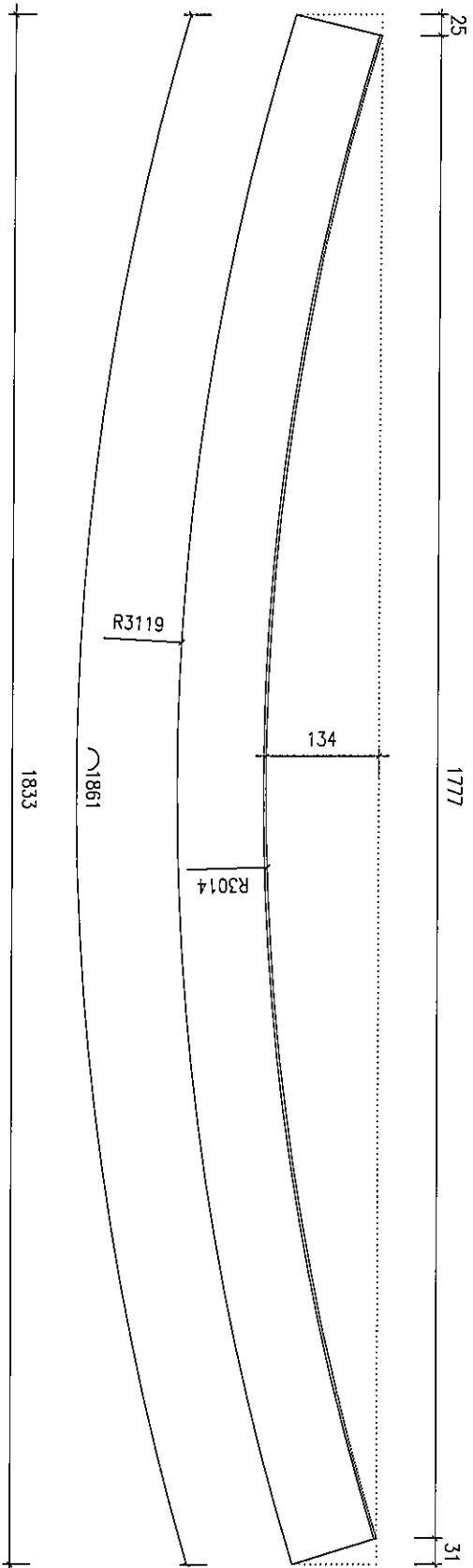
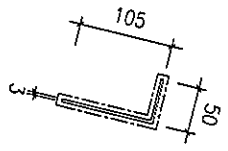

J836-AA-423
50x105x3mm 厚鋁角
顏色：TUC51602XL(RY)-3 深灰色
數量共 1件

57

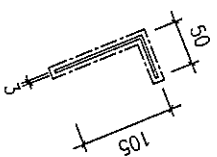
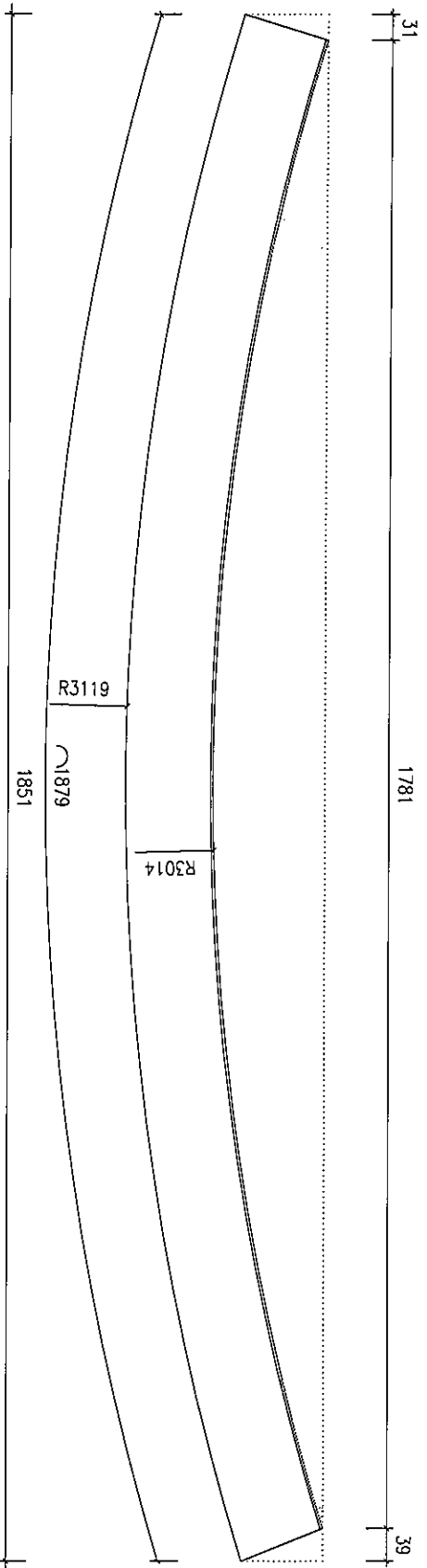
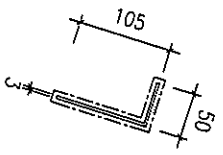

J836-AA-425
50x105x3mm 厚鋁角
顏色：TUC51602XL(RY)-3 深灰色
數量共 1 件

29

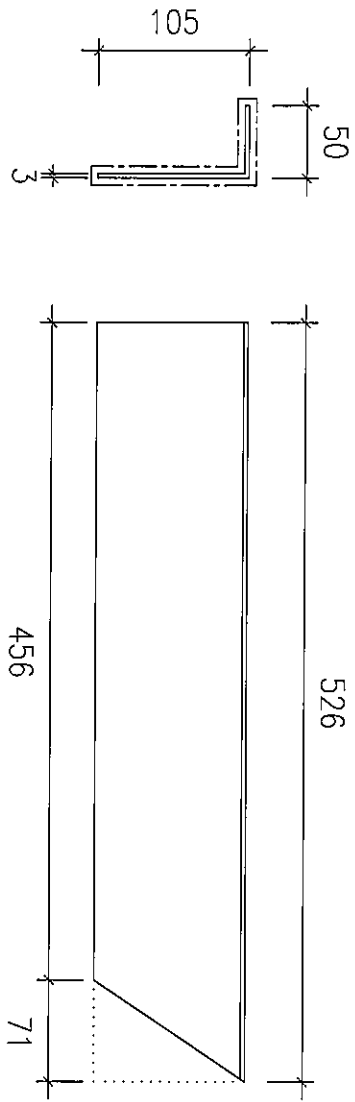

J836-AA-426
50X105X3mm 厚鋁角
顏色：TUC51602XL(RY)-3 深灰色
數量 共 1 件

32

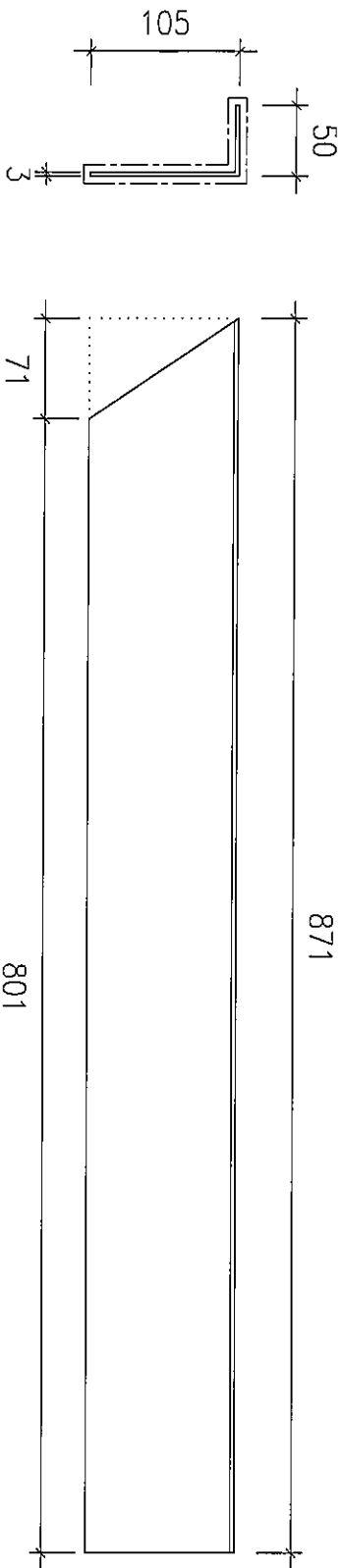

J836-AA-427

50x105x3mm 厚鋁角

顏色：TUC51602XL(RY)-3 深灰色

數量共 1 件

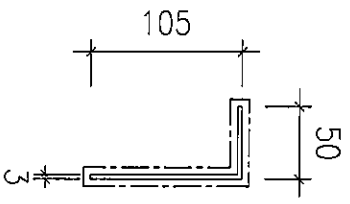

2090

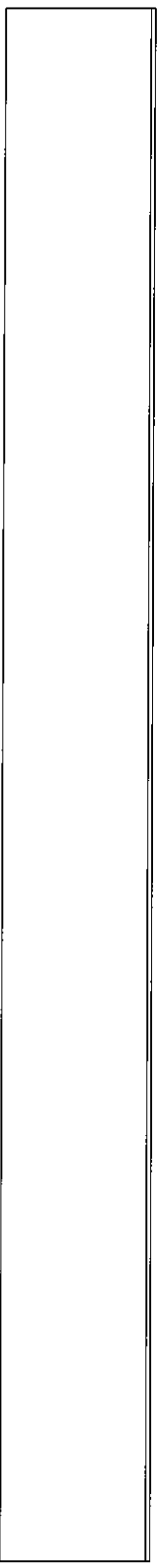

J836-AA-428
50x105x3mm 厚鋁角
顏色：TUC51602XL(RY)-3 深灰色
數量共 1 件

31

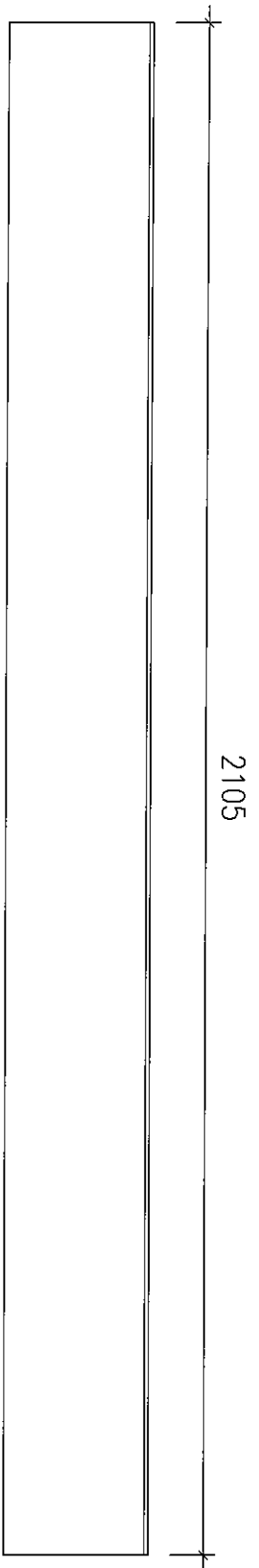
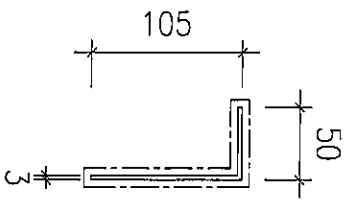

J836-AA-429
50x105x3mm 厚鋁角
顏色：TUC51602XL(RY)-3 深灰色
數量共 1 件

32

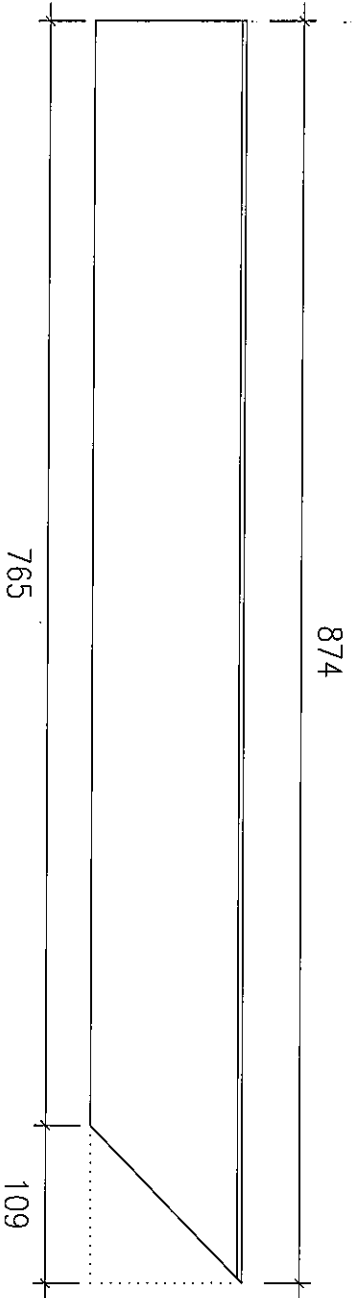
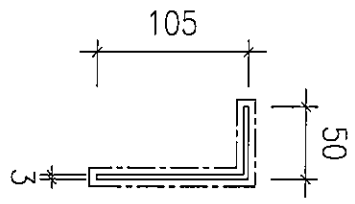

J836-AA-430
50x105x3mm 厚鋁角
顏色：TUC51602XL(RY)-3 深灰色
數量共 1 件

33

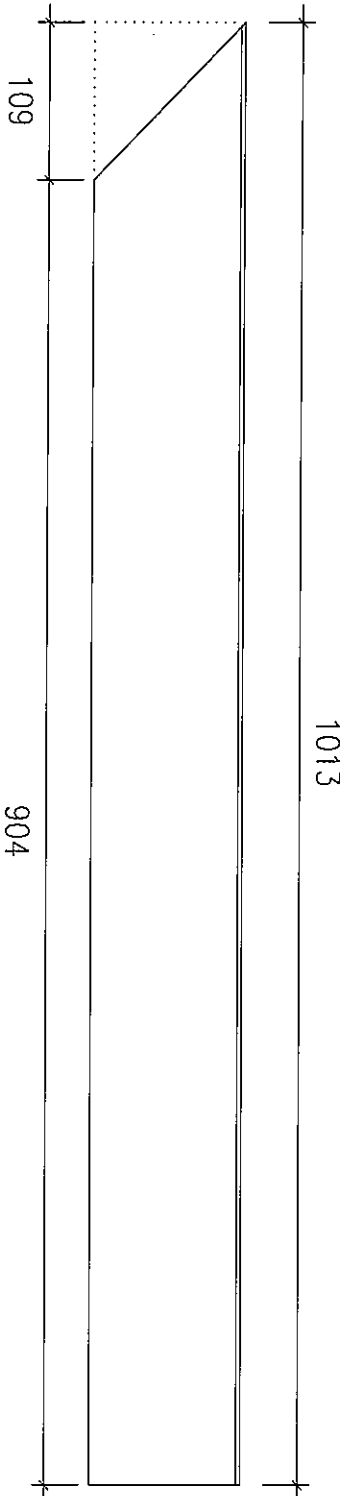
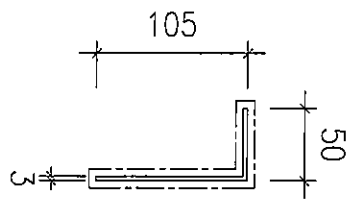

J836-AA-431
50X105X3mm 厚鋁角
顏色：TUC51602XL(RY)-3 深灰色
數量共 1件

340

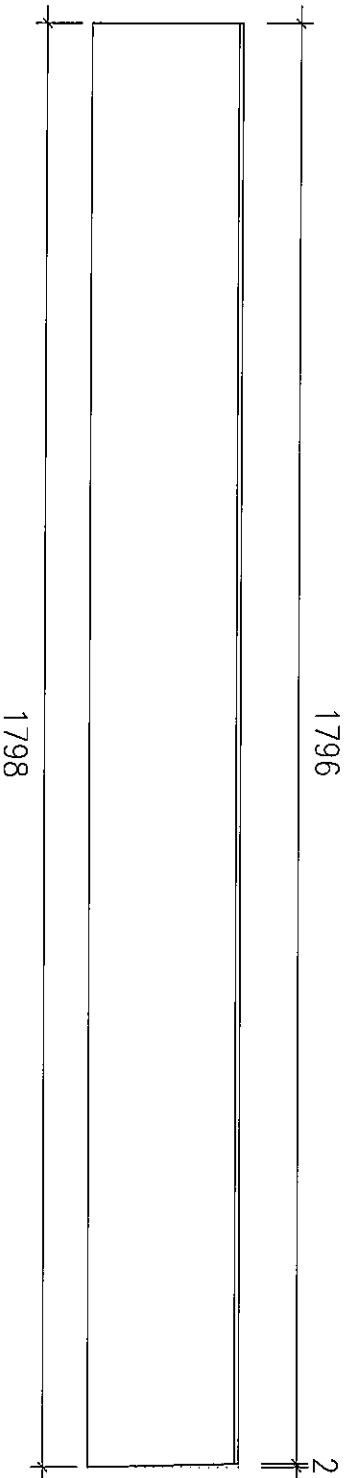
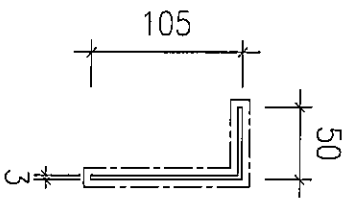

J836-AA-432
50x105x3mm 厚鋁角
顏色：TUC51602XL(RY)-3 深灰色
數量共 1件

35

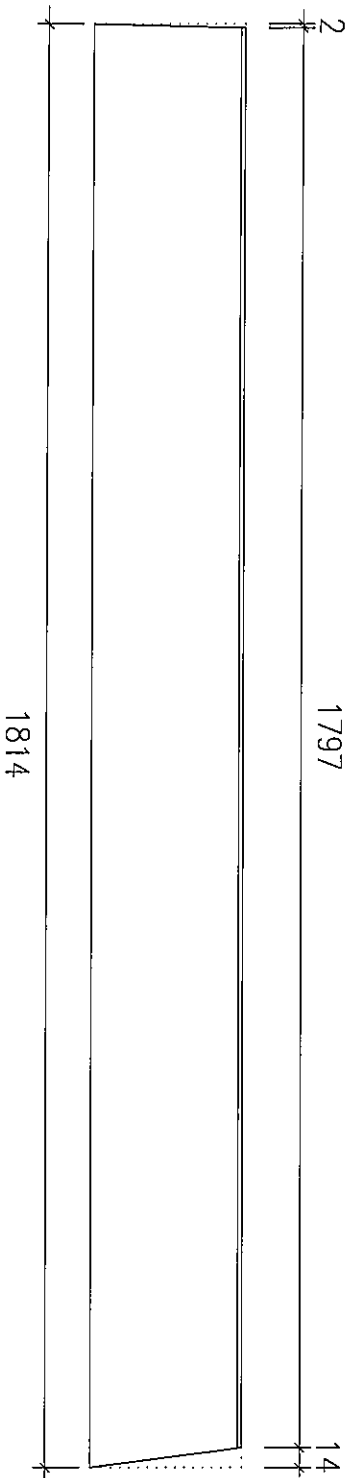
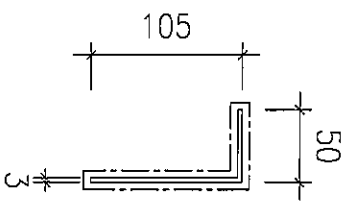

J836-AA-433
50x105x3mm 厚鋁角
顏色：TUC51602XL(RY)-3 深灰色
數量共 1 件

361

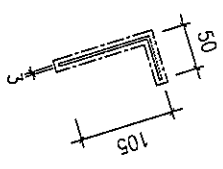
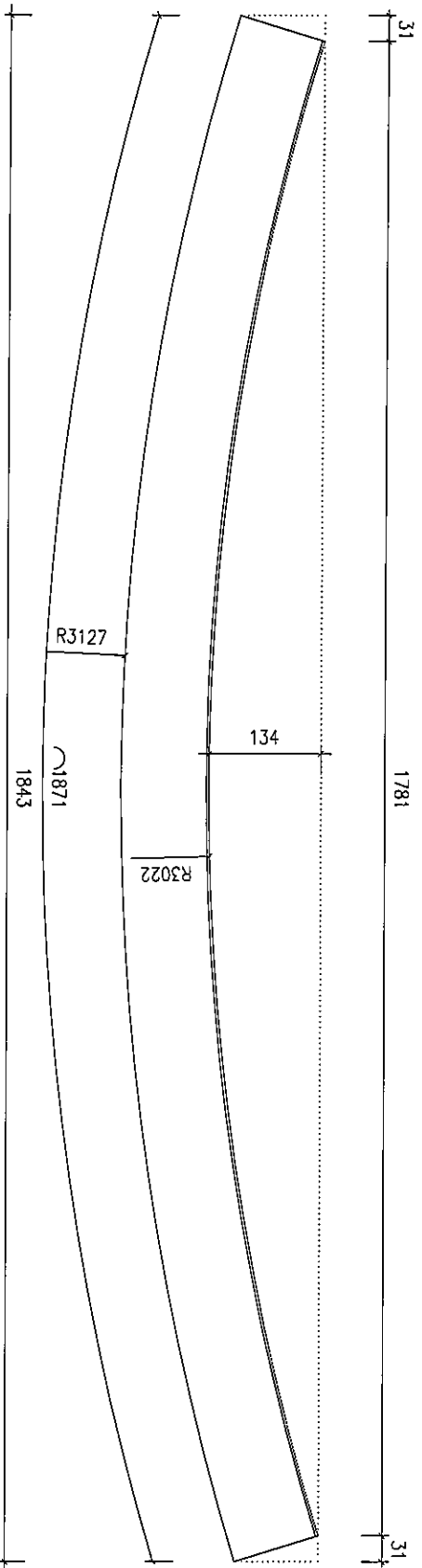
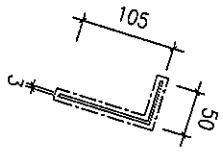

J836-AA-434

50x105x3mm 厚鋁角

顏色：TUC51602XL(RY)-3 深灰色

數量 共 2 件

37

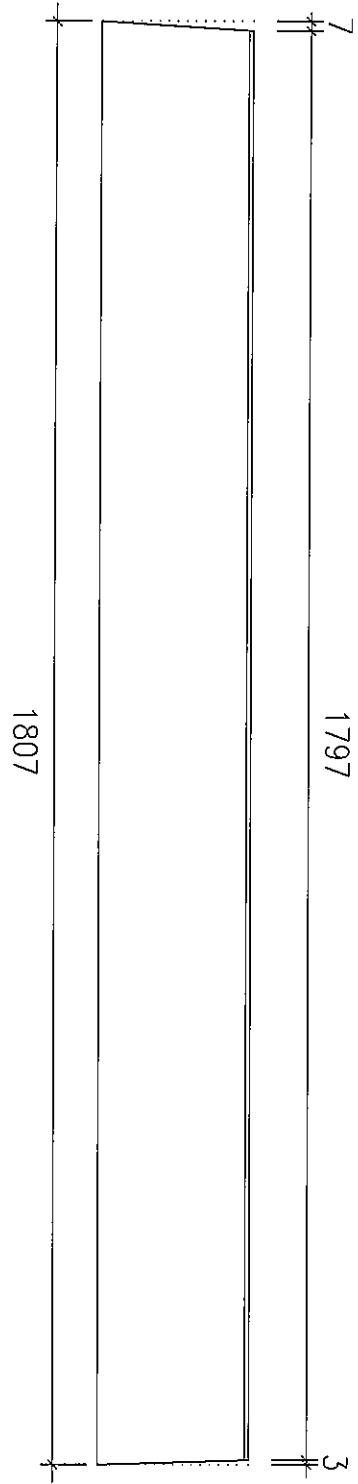
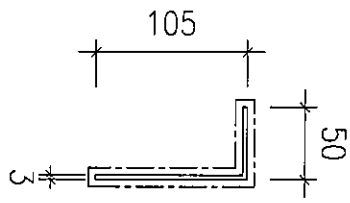

J836-AA-435
50X105X3mm 厚鋁角
顏色：TUC51602XL(RY)-3 深灰色
數量共 1件

38

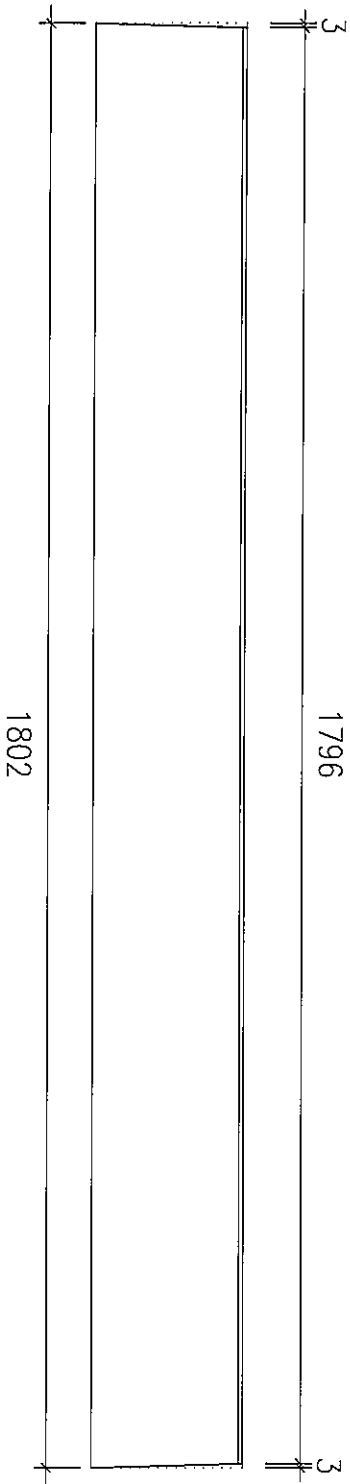
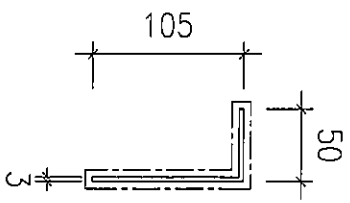

J836-AA-436
50x105x3mm 厚鋁角
顏色：TUC51602XL(RY)-3 深灰色
數量共 1 件

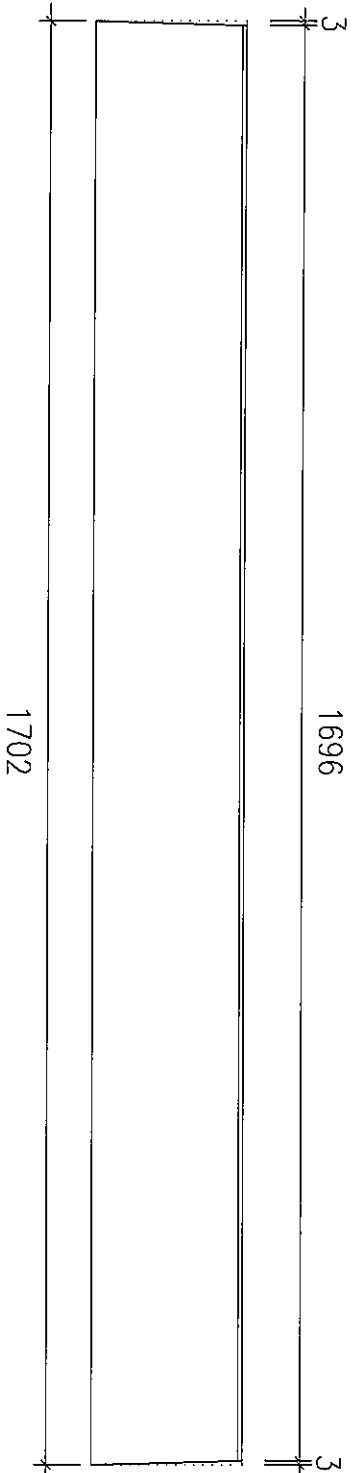
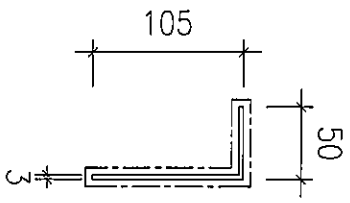

J836-AA-437
50X105X3mm 厚鋁角
顏色：TUC51602XL(RY)-3 深灰色
數量共 1 件

48

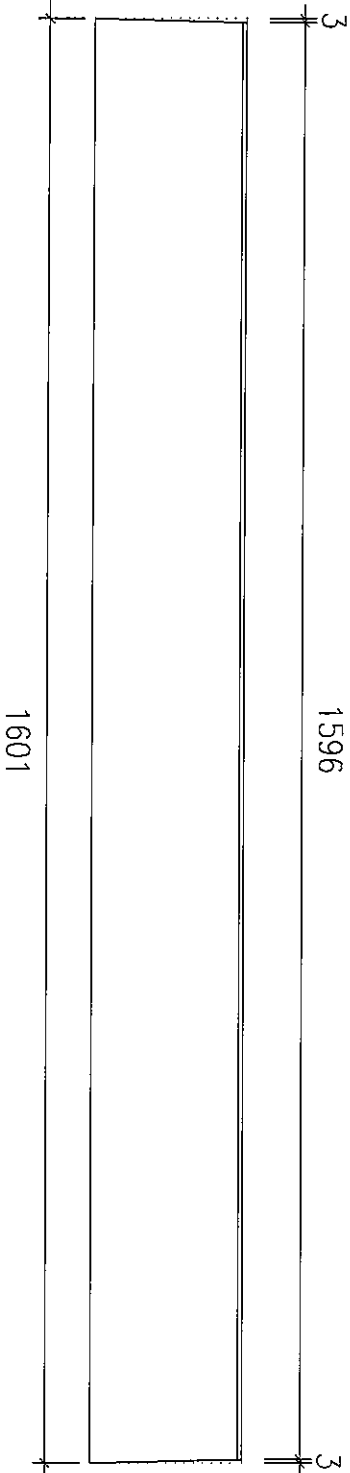
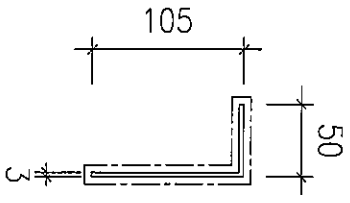

J836-AA-438
50X105X3mm 厚鋁角
顏色: TUC51602XL(RY)-3 深灰色
數量共 1 件

(CP)

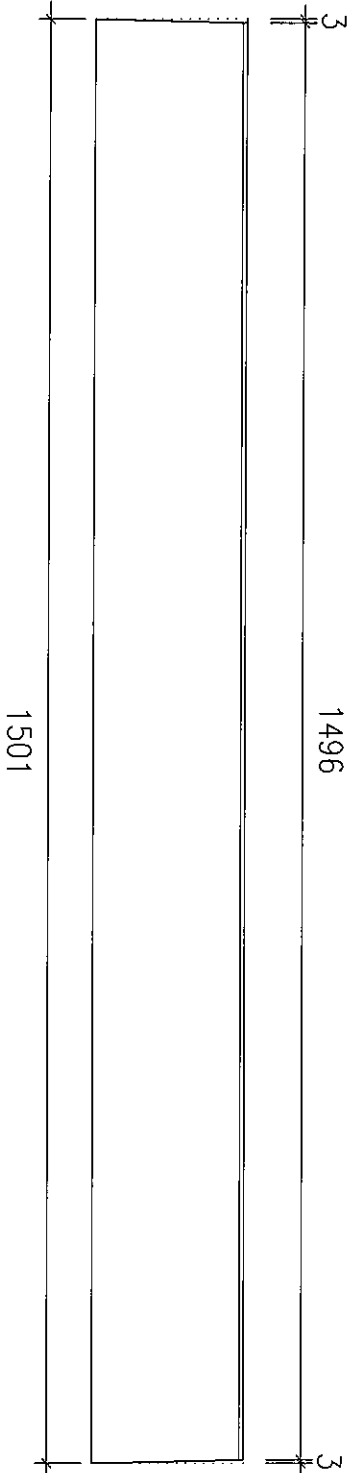
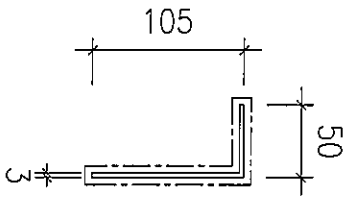

J836-AA-439
50X105X3mm 厚鋁角
顏色：TUC51602XL(RY)-3 深灰色
數量共 1 件

(42)

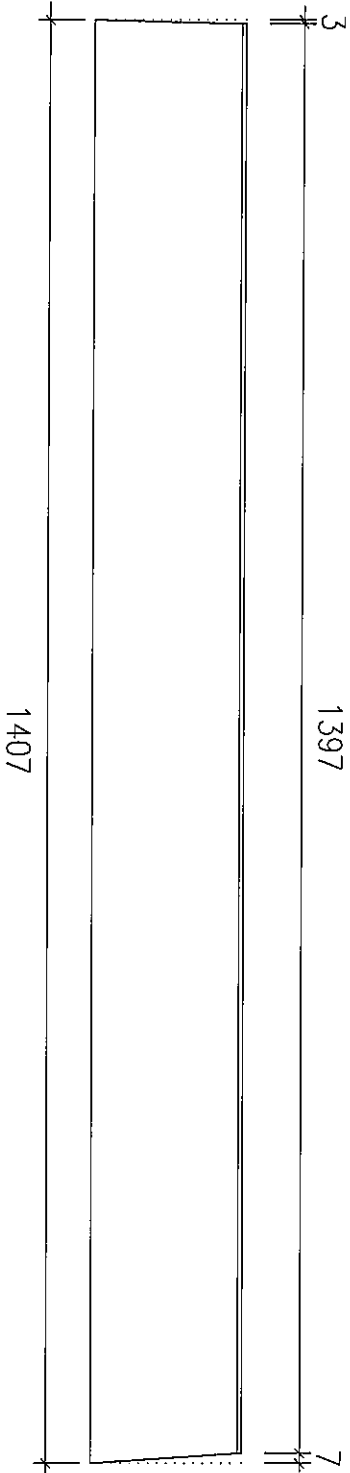
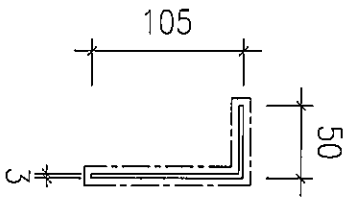

J836-AA-440
50X105X3mm 厚鋁角
顏色：TUC51602XL(RY)-3 深灰色
數量共 1件

43

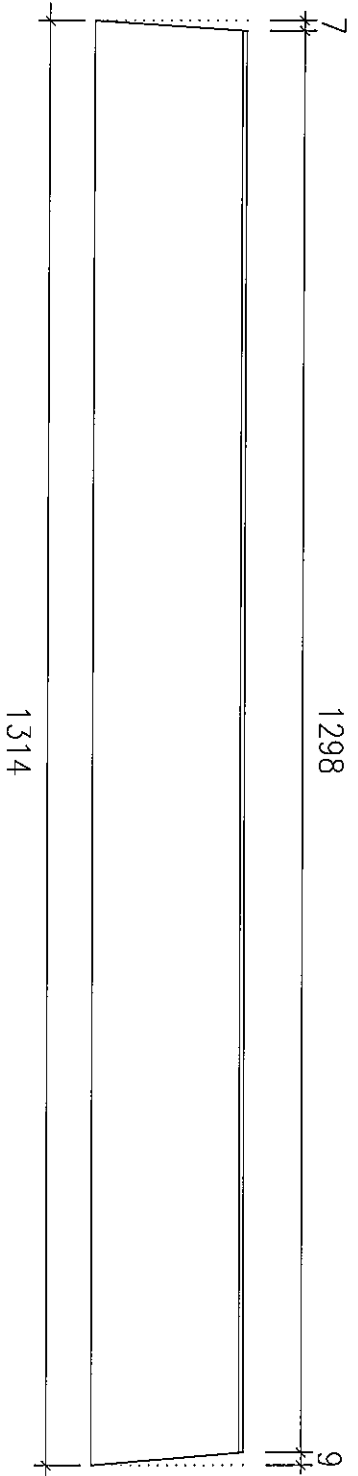
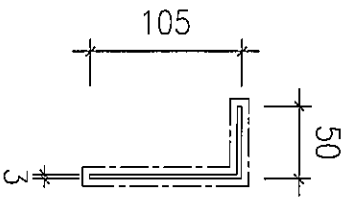

J836-AA-441
50X105X3mm 厚鋁角
顏色：TUC51602XL(RY)-3 深灰色
數量 共 1 件

(44)

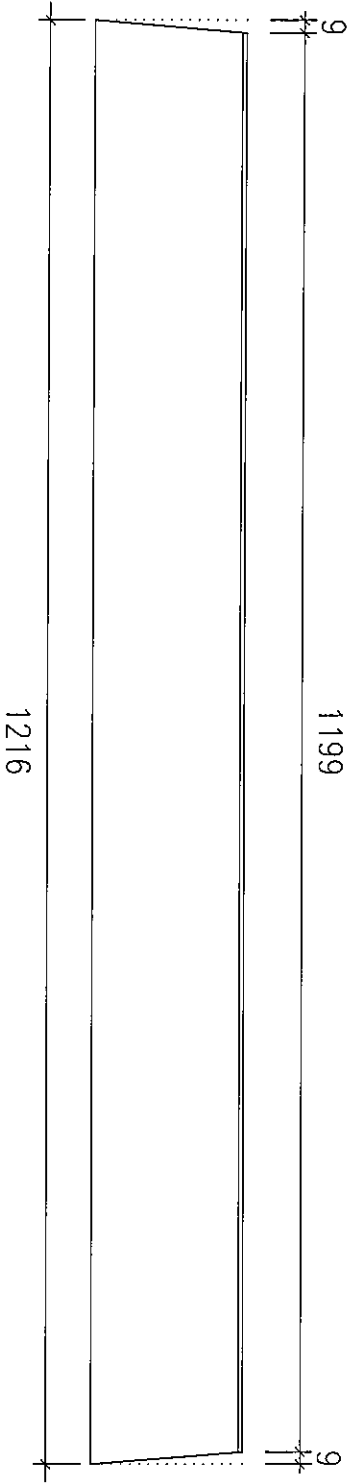
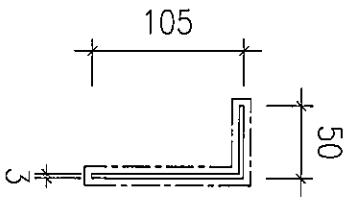

J836-AA-442
50X105X3mm 厚鋁角
顏色：TUC51602XL(RY)-3 深灰色
數量 共 5 件

(45)

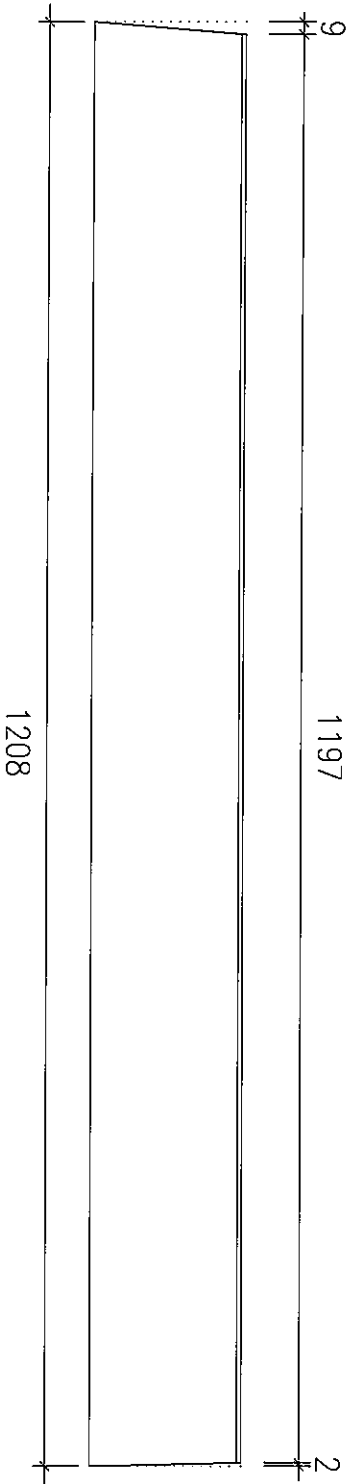
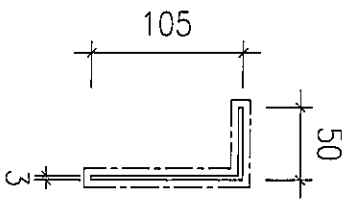

J836-AA-443
50X105X3mm 厚鋁角
顏色：TUC51602XL(RY)-3 深灰色
數量共 1件

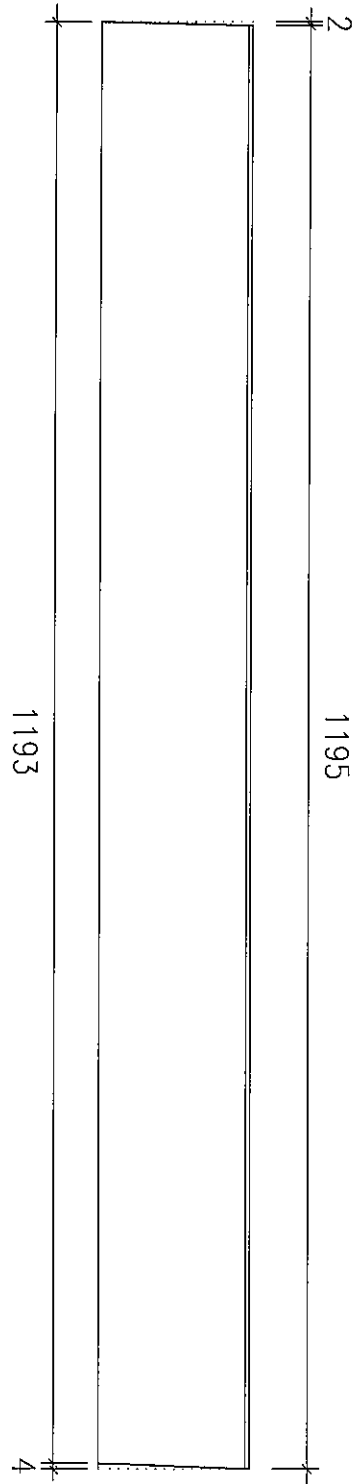
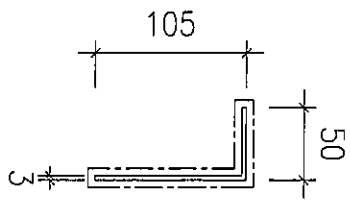

J836-AA-444

50X105X3mm 厚鋁角

顏色：TUC51602XL(RY)-3 深灰色

數量 共 1 件



UNDER SEPARATED
SI-UB-26248
顶部防水位加装太阳能板
* 包含、内位置

94/A

①

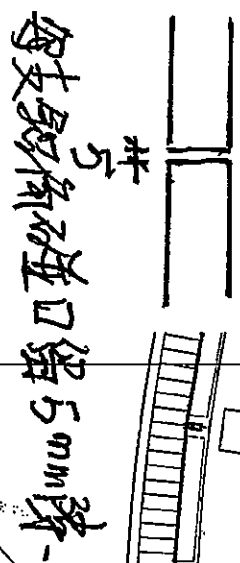

②



窗框规格以时

③

所有长度请按最新图计算

共5件

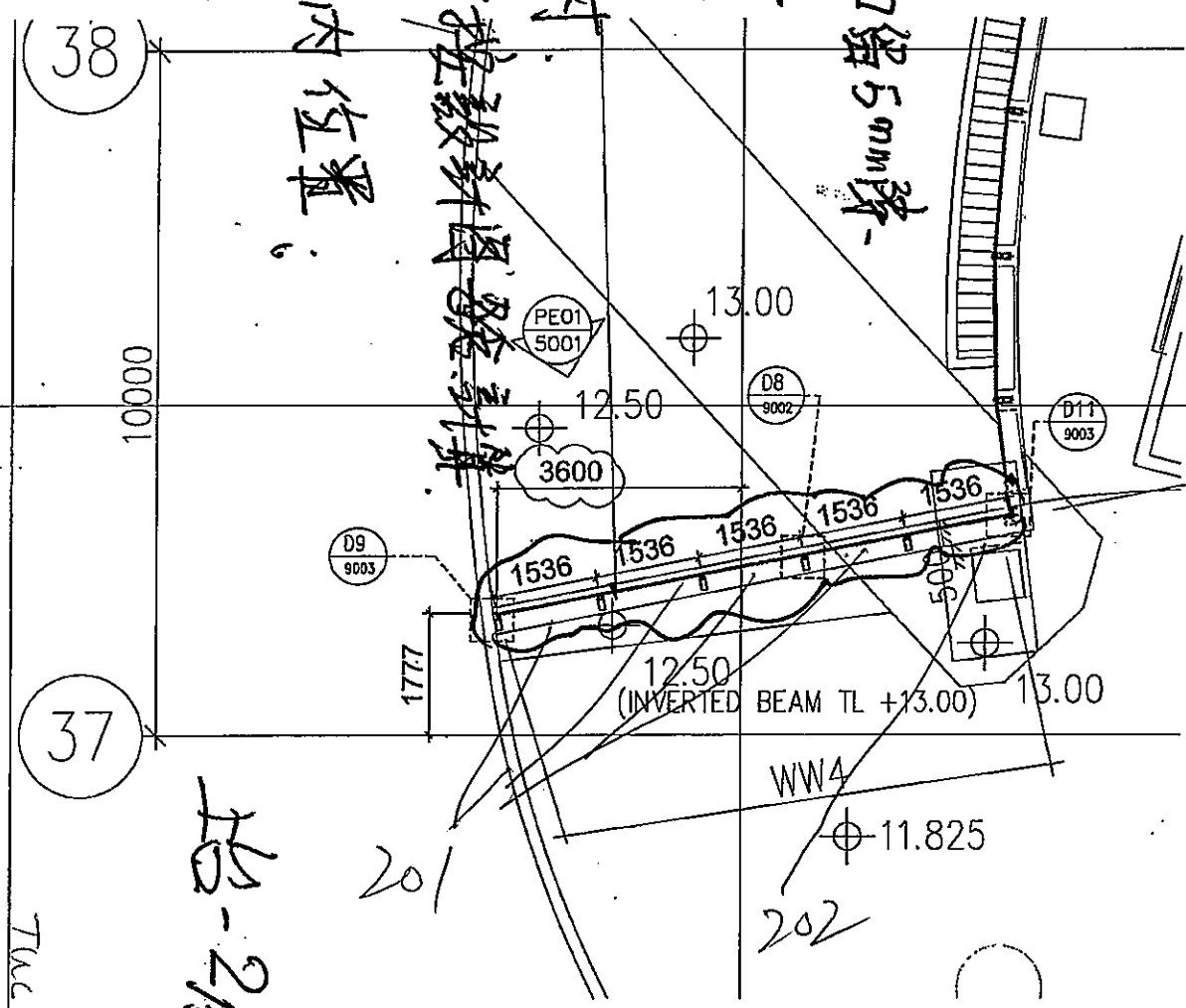

PP01 3001 PART PLAN OF WINDOW-WALL (WW4) @2/F

HS-2/F WW4

TWC 51602 (47).3

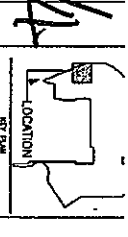

MTR

ARCHITECT: MTR Architects and Engineers Ltd

UNIT CONTRACTOR: CHINA OVERSEAS BUILDING CONSTRUCTION LTD.

STRUCTURAL ENGINEER: ARUP

FRAME CONSULTANT: WEINHARDT

NOTE:
1. ALL DIMENSIONS ARE IN MM.
2. ALL DIMENSIONS ARE VARIOUS FROM CURSE
UNLESS OTHERWISE SPECIFIED OR NOTED ON SITE
BORING INFORMATION.

LEGEND:
① DETAIL WORK NO.
② REF. SHEET NO.
1. FFL -- FINISHED FLOOR LEVEL
2. SFL -- STRUCTURAL FLOOR LEVEL
1. ⊕ -- REINFORCED DETAIL

NO.	DESCRIPTION	QTY	UNIT
1	210x50x2414	1	PC
2	210x50x2414	1	PC
3	210x50x2414	1	PC
4	210x50x2414	1	PC
5	210x50x2414	1	PC
6	210x50x2414	1	PC
7	210x50x2414	1	PC
8	210x50x2414	1	PC
9	210x50x2414	1	PC
10	210x50x2414	1	PC
11	210x50x2414	1	PC
12	210x50x2414	1	PC
13	210x50x2414	1	PC
14	210x50x2414	1	PC
15	210x50x2414	1	PC
16	210x50x2414	1	PC
17	210x50x2414	1	PC
18	210x50x2414	1	PC
19	210x50x2414	1	PC
20	210x50x2414	1	PC
21	210x50x2414	1	PC
22	210x50x2414	1	PC
23	210x50x2414	1	PC
24	210x50x2414	1	PC
25	210x50x2414	1	PC
26	210x50x2414	1	PC
27	210x50x2414	1	PC
28	210x50x2414	1	PC
29	210x50x2414	1	PC
30	210x50x2414	1	PC
31	210x50x2414	1	PC
32	210x50x2414	1	PC
33	210x50x2414	1	PC
34	210x50x2414	1	PC
35	210x50x2414	1	PC
36	210x50x2414	1	PC
37	210x50x2414	1	PC
38	210x50x2414	1	PC

PROJ. NO.: J-836
PROJECT: PROPOSED SITE C1 DEVELOPMENT AT AREA 95, TMOU 20 RD, TSEUNG KWAN O, NEW TERRITORIES
TITLE: PART PLAN FOR WINDOW-WALL (WW4) @ 2/F
DATE: 03-MAY-2018 SCALE: 1:75
DRAWN BY: C.F. CHECKED BY: J.L.K.
MTR Architects and Engineers Ltd
110 King's Road, 11/F, Kowloon
Tel: 27383311 Fax: 27383306
MTR ID: J0306-WYVWNL-3001 Rev.: 1/1A

SI-ND₂ 26248

顶部防水井位加大规格 竣工记录

①

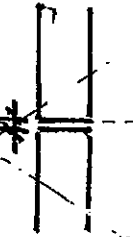

增加规格口留5mm砾

②

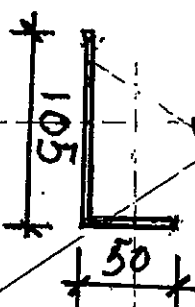

原有规格核对

③

所有长度请按竣工图核算

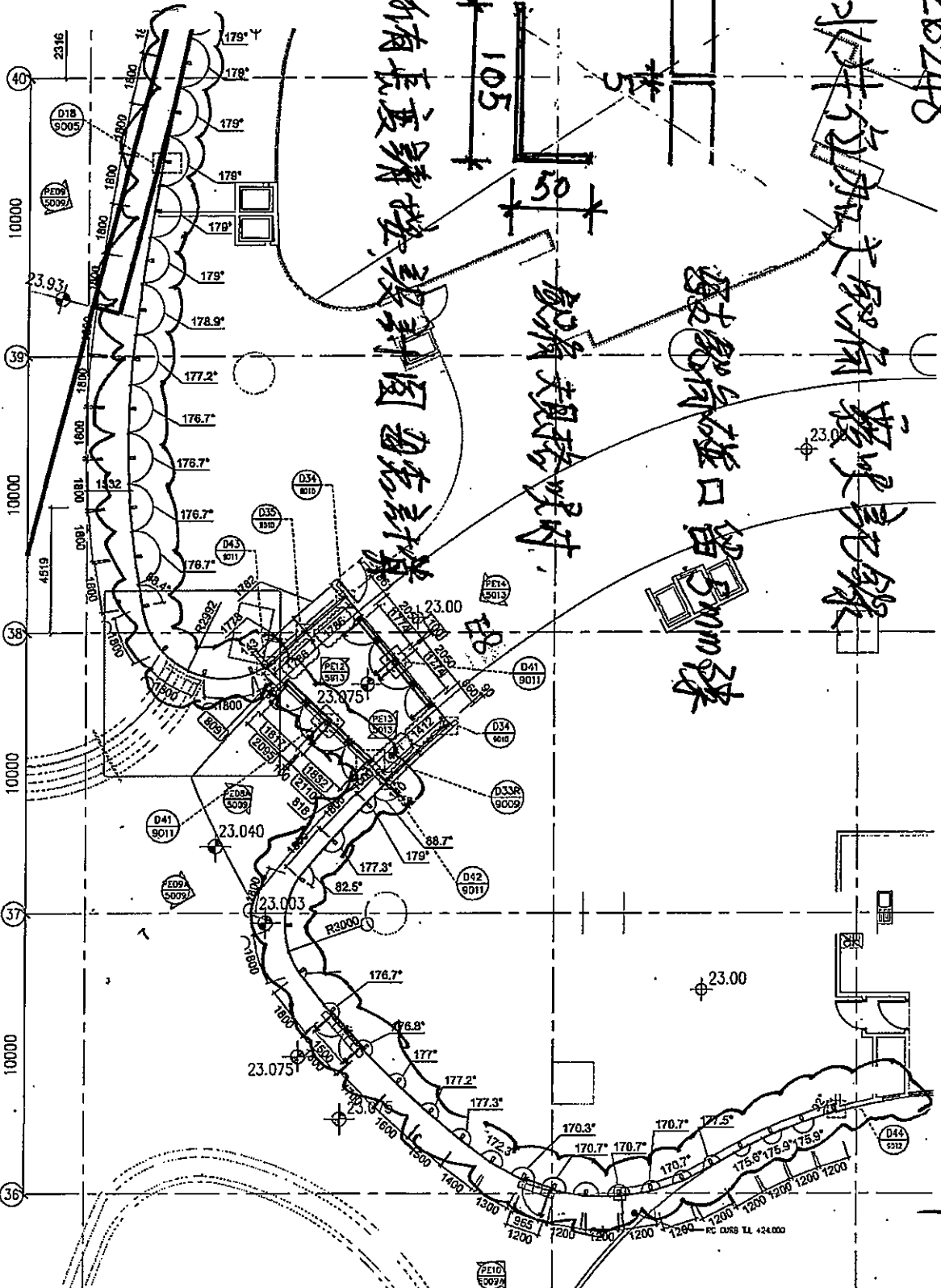

* 包含口内位置

IG-4F-10004 共4册



P&T Architects and Engineers Limited

33/F, 633 King's Road
 North Point, Hong Kong
 Telephone : 2575 6575
 Fax : 2891 3834

Contract Instruction

CONTRACTOR'S COPY

Job	Lohas Park Package Seven at TKOTL 70RP, Site C1, New Territories	Job No.	5138A
Contractor	China Overseas Building Construction Limited - Main Contract Works - Package A	Date	6 February 2020
		Instruction No.	CI-MCA-A-173 P.1 of 1

No.	Instruction	Cost
	<p>Where applicable the contract sum will be adjusted in accordance with the contract conditions.</p> <p>Confirmation of dark grey colour for aluminum decorative flashing</p> <p>This CI serves to cover P&T's email dated 2 October 2018 (Appendix A) regarding confirmation on aluminum flashing in dark grey color for window wall WW4.</p> <p>Please proceed coordination works, submit material/ shop drawings and complete a mock-up for RSS team's review and acceptance prior to the site works.</p> <p>Time and cost implication shall be further assessed by LS.</p> <p>Encl.</p> <p>AC/TCHOW/WHNN</p>	

Copies to :	<input checked="" type="checkbox"/> Contractor	COBC*	<input checked="" type="checkbox"/> Stru Engineer	ARUP	<input checked="" type="checkbox"/> Interior Designer	CL3	<input checked="" type="checkbox"/> RA/ COW
	<input checked="" type="checkbox"/> Client	VSL	<input checked="" type="checkbox"/> EM Engineer	MME	<input checked="" type="checkbox"/> Façade Consultant	MFT	<input checked="" type="checkbox"/> RE
	<input checked="" type="checkbox"/> Client	MTR*	<input checked="" type="checkbox"/> Landscape	ADI	<input checked="" type="checkbox"/> Beam Plus	WSP	<input checked="" type="checkbox"/> RBSE
			<input checked="" type="checkbox"/> QS	ARC*	<input checked="" type="checkbox"/> Environ & Safety	WSP	

* with hardcopy

Issued by P&T Architects and Engineers Limited

Authorised by :

Tony Chow

Angus Chan
 for P&T Architects and Engineers
 Limited

Appendix A

From: Alex SIN
Sent: 2018年10月2日 星期二 18:27
To: hk cs; 5138a@p-t-group.com(Cloud); Vincent YIP (4877b); Chan Chau Kwai Michael; midi@midiltd.com.hk
Cc: Kin Wing Cheng; Terry Chan; Fok Kwun Lok-WPL BSC; benau@wheelockpropertieshk.com; davyko@wheelockpropertieshk.com; Mr. Will Yu; Mr. Elden chung; Mr. Terry Cheng; Mr. Benjamin Chan; Mr. Jimmy For; KP Tam-WPL; Stanley So; Vincent Lai-WPL; Daisy Cheng-WPL; Wilson Lau-WPL CM; Edward Wong-MTR; SL Kwan-MTR; LO SY Shuk Yi (羅淑怡); NG Allen Chi Yan (吳子殷); FAN Tony Siu Ching (范少青); LEE Ada Yee Nan (李綺年); VICTORNG@mtr.com.hk; Simon Fung-MTR; Barry Lai-MTR; CHENG Jackson Kwan Pui (鄭焜沛); TSE Keith Wing Keung (謝永強); Dennis Wong-MTR; Ken Tse-MTR; cliffy@mtr.com.hk; HF Au-MTR; ARUP (Ove Arup); HKG TKO-PH7-Site; Vincent Kwok; Daniel Tso; MFT Project Email; LOHASPARK7@hk.langdonseah.com; Wong, Wency Man-Sze; Ng, Anthea Kar-Wai; Tse, Dennis Chun-Pan; Lam, Heidi Ying-Hei; William Tsang; Ng, Wai Lok (CN - Hong Kong)
Subject: RE: Lohas Park P7 : Package A – SD(A)0357 – MIDI – 7th Submission of Shop Drawing for Window Wall WW4 (G.L A-N)

Dear COBC and Midi:

Further to our discussion today, please see attached comments for your onward action. Please revise some part layouts and details as per comments.

[ftp://61.244.114.162/20181002%20Response%20for%20SD-A-0357%207th%20submission%20of%20SD%20for%20window%20wall%20WW4%20\(GL%20A-N\)/](ftp://61.244.114.162/20181002%20Response%20for%20SD-A-0357%207th%20submission%20of%20SD%20for%20window%20wall%20WW4%20(GL%20A-N)/)

login: pt5138amcw
pw:ptftp4495

Regards
Alex Sin

From: hk cs <cstko2017@gmail.com>
Sent: Friday, September 21, 2018 4:33 PM
To: P&Ta <5138a@p-t-group.com>; Vincent Yip-COW <vincentyip@p-t-group.com>; Alex Sin <alexsin@p-t-group.com>; Michael Chan-RA <michaelchan@p-t-group.com>
Cc: Kin Wing Cheng <kinwing_cheng@cohl.com>; Terry Chan <terryschan@wheelockpropertieshk.com>; Fok Kwun Lok-WPL BSC <klfok@wheelockpropertieshk.com>; benau@wheelockpropertieshk.com; davyko@wheelockpropertieshk.com; Mr. Will Yu <willyu@wheelockpropertieshk.com>; Mr. Elden chung <eldenchung@wheelockpropertieshk.com>; Mr. Terry Cheng <terrycheng@wheelockpropertieshk.com>; Mr. Benjamin Chan <benjaminchan@wheelockpropertieshk.com>; Mr. Jimmy For <jimmyfok@wheelockpropertieshk.com>; KP Tam- WPL <kptam@wheelockpropertieshk.com>; Stanley So <stanleyso@wheelockpropertieshk.com>; Vincent Lai-WPL <vincentlai@wheelockpropertieshk.com>; Daisy Cheng-WPL <daisycheng@wheelockpropertieshk.com>; Wilson Lau-WPL CM <wilsonlau@wheelockpropertieshk.com>; Edward Wong-MTR <edwong@mtr.com.hk>; SL Kwan-MTR <slkwan@mtr.com.hk>; LO SY Shuk Yi (羅淑怡) <SYLO@mtr.com.hk>; NG Allen Chi Yan (吳子殷) <ALLENNG@mtr.com.hk>; FAN Tony Siu Ching (范少青) <tonyfan@mtr.com.hk>; LEE Ada Yee Nan (李綺年) <adalee@mtr.com.hk>; VICTORNG@mtr.com.hk; Simon Fung-

MTR <kkfung@mtr.com.hk>; Barry Lai-MTR <LAIBYTSC@mtr.com.hk>; CHENG Jackson Kwan Pui (鄭昆沛) <kpcheng@mtr.com.hk>; TSE Keith Wing Keung (謝永強) <wkkkse@mtr.com.hk>; Dennis Wong-MTR <WDENNIS@mtr.com.hk>; Ken Tse-MTR <cktsekt@mtr.com.hk>; cliffy@mtr.com.hk; HF Au-MTR <HOFOAU@mtr.com.hk>; ARUP (Ove Arup) <hkg.tko-phase7@arup.com>; HKG TKO-PH7-Site <hkg.tko-ph7-site@arup.com>; Vincent Kwok <Vincent.kwok@arup.com>; Daniel Tso <daniel.tso@arup.com>; MFT Project Email <15/80180@mfacade.com>; LOHASPARK7@hk.langdonseah.com; Wong, Wency Man-Sze <Wency.Wong@wsp.com>; Ng, Anthea Kar-Wai <Anthea.Ng@wsp.com>; Tse, Dennis Chun-Pan <Dennis.Tse@wsp.com>; Lam, Heidi Ying-Hei <heidi.lam@wsp.com>; William Tsang <william_tsang@cohl.com>; Ng, Wai Lok (CN - Hong Kong) <wailok_ng@cohl.com>
Subject: Lohas Park P7 : Package A – SD(A)0357 – MIDI – 7th Submission of Shop Drawing for Window Wall WW4 (G.L A-N)

Dear Sir,

Attached is the captioned Shop Drawing Submission (Ref. COBC/BHX/B1/2018/SD(A)/0357) for your perusal.

Thank you for your kind attention.

Best Regards
Amy Wu
Site Clerk
Lohas Park Package 7
CHINA OVERSEAS BLDG. CONSTRUCTION LTD.

oBHX-SD-A-0357.pdf