

工程指示 / 要求簡箋(E.I.)

工程指示編號：EI/ 0306 /19

修改版次：

工程編號：J836

工程名稱：日出康城7期(平台)

工程項目：Cooling Tower 防墜扣

收件人：Maggie Lok

發件人：Joe Chan

日期：14/3/2019

要求提供 / 確認 事項：

- () 初步鋁料 B.M. () 加工拆圖，然後生產 () 尺寸表
- () 正式鋁料 B.M. () 技術上資料 / 指示 () 報價
- () 配件 B.M. () 樣辦或貨品說明書 () 分判合約
- () 其他：_____

內容：請依附件資料，訂購不銹鋼防墜扣，共

130 隻。
(髮絲面)

驗焊 = 20% 滲透

- 316 不銹鋼

100% 目測

請在 30/4/2019 前完成上列要求。

附有關圖紙 / 文件：

5頁

以上項目為：

- 原合約工程包 原合約工程加 / 減賬 新工程報價

原因：-

分發東莞各部門：

- () 生產技術總監 連附件 () 技術部 連附件 () 生產部 連附件 () 機械設計部 連附件
- () 採購部 連附件 () 生產統籌部 連附件
- () 質檢部 連附件 () 會計部 連附件 () 報關組 連附件 () 其他 _____ 連附件

分發香港各部門：

- () 行政部 連附件 () 會計部 連附件 () 統籌部 連附件 () 工程部地盤科文 () 連附件 積哥
- () 採購部 連附件 () QS 部 () 連附件 () 維修部 連附件 () 其他 _____ 連附件

傳遞編號：

發件人簽署：

項目經理簽署：

①

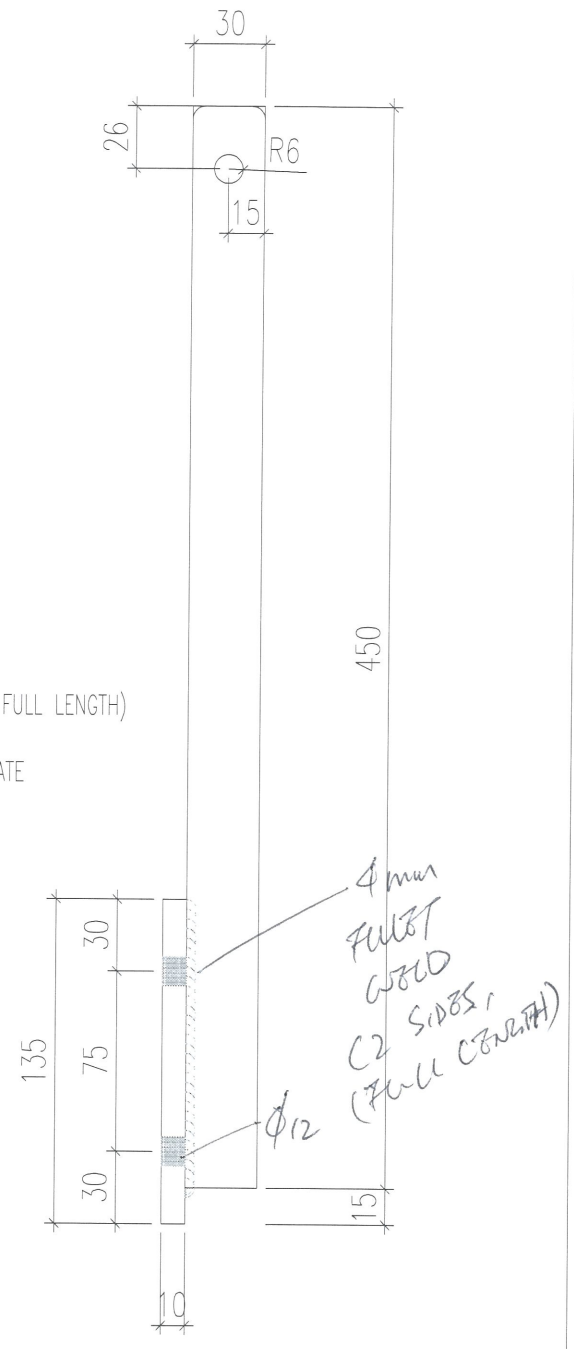
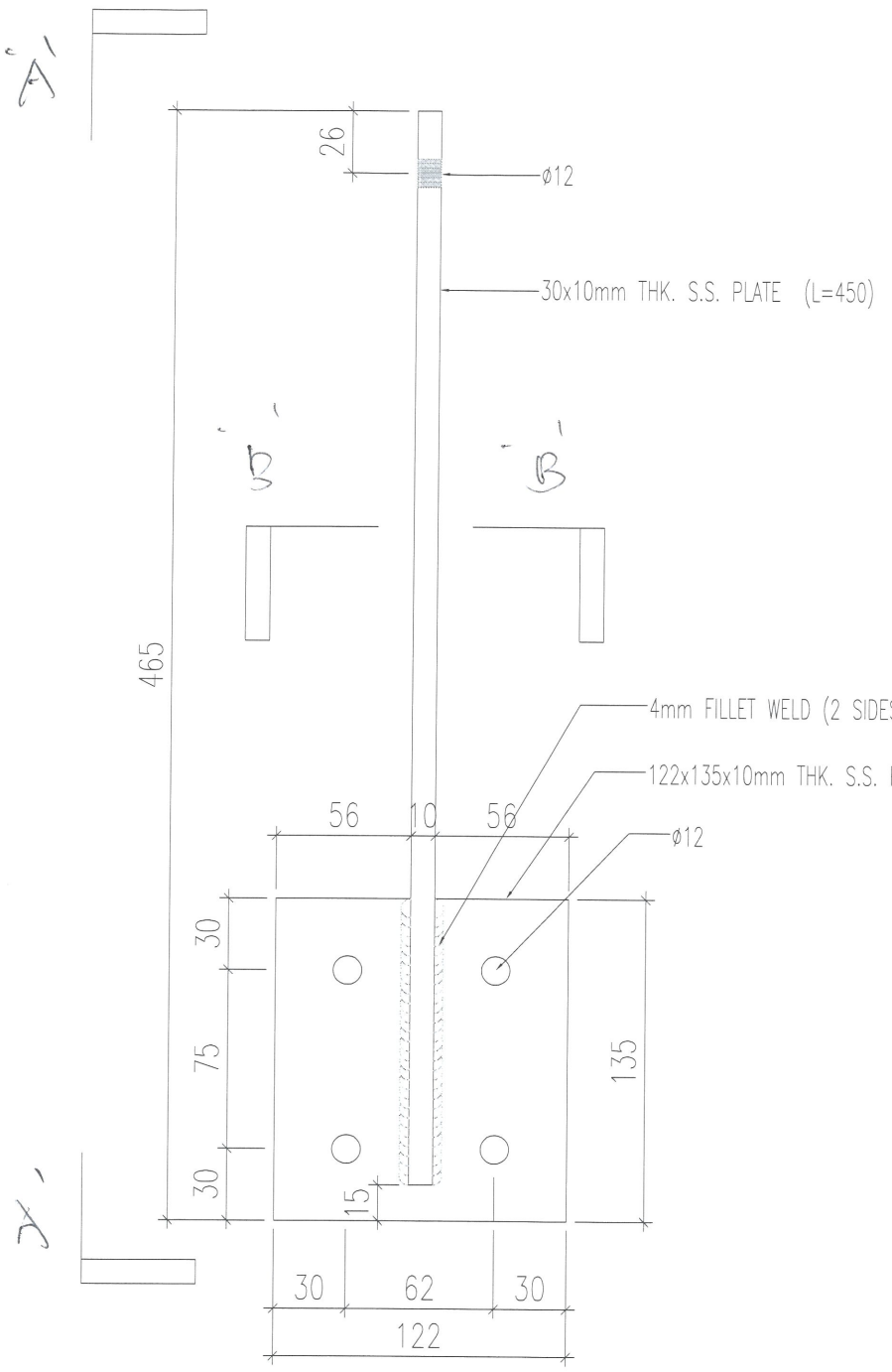

SECTION A-A

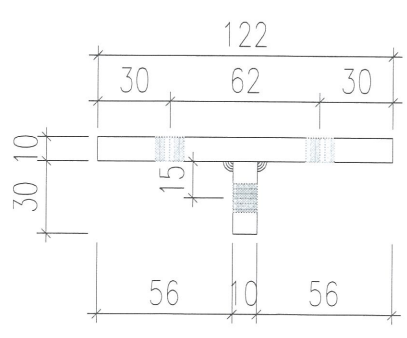

SECTION B-B

2.35 kg/pc.

共 125 隻 + 5 隻 = 130 隻

FOR Cooling Tower
Sum. figures.

5

ADVANCED COPY

CONTRACTOR'S COPY

Contract Instruction

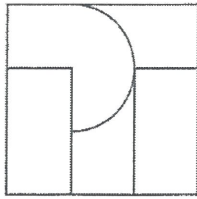

**P&T Architects
and Engineers
Ltd**

33/F, 633 King's Road
North Point, H.K.
Telephone : 2575 6575
Fax : 852-2891 3834

Job

Lohas Park Package Seven at TKOTL 70RP, Site C1,
New Territories.
Main Contract Works- Package A

Job
No.

5138A

Contractor

China Overseas Building Construction Limited

Date

16 Nov 2018

Instruction Nos.

CI-MCA-A-051

P.1 of 2

No.	Instruction	Cost																								
	Where applicable the contract sum will be adjusted in associated with the contract conditions.																									
	<p><u>Confirmation on Design Changes</u></p> <p>This CI serves to cover the following design changes as per P&T's emails list below for your construction. There shall be no time implication and cost subject to QS's assessment:</p> <table border="1"> <thead> <tr> <th>Item</th> <th>Date of information / confirmation conveyed to COBC via email</th> <th>Remark</th> </tr> </thead> <tbody> <tr> <td>1. Fritted pattern on glass cladding GC1 at Ice Rink</td> <td>28 Sep 2018 (Reply to RFI/A/504)</td> <td>Appendix 1</td> </tr> <tr> <td>2. Confirmation of mullion colour for window wall WW1, WW2, WW3 and WW4 to Dark Grey colour</td> <td>20 Jul 2018 (at Façade meeting with MTR)</td> <td>Appendix 2</td> </tr> <tr> <td>3. Confirmation of 4 colours for Cooling Tower Louvre</td> <td>19 Sep 2018 (by email)</td> <td>Appendix 3</td> </tr> <tr> <td>4. Clarification of Fall arrest system at Cooling Tower</td> <td>9 Nov 2018 (by email)</td> <td>Appendix 4</td> </tr> <tr> <td>5. Window Wall WW4 (N-RH) 3/F layout change</td> <td>19 Sep 2018 (comment on WW4 shopdrawing SD(A) 308 by email)</td> <td>Appendix 5</td> </tr> <tr> <td>6. Clarification of E6 Entrance</td> <td>22 Oct 2018 and 31 Oct 2018 (Reply to RFI/A/619)</td> <td>Appendix 6</td> </tr> <tr> <td>7. Clarification of rainwater downpipe and gutter for Window Wall WW3 canopy</td> <td>31 Oct 2018 (by email)</td> <td>Appendix 7</td> </tr> </tbody> </table>	Item	Date of information / confirmation conveyed to COBC via email	Remark	1. Fritted pattern on glass cladding GC1 at Ice Rink	28 Sep 2018 (Reply to RFI/A/504)	Appendix 1	2. Confirmation of mullion colour for window wall WW1, WW2, WW3 and WW4 to Dark Grey colour	20 Jul 2018 (at Façade meeting with MTR)	Appendix 2	3. Confirmation of 4 colours for Cooling Tower Louvre	19 Sep 2018 (by email)	Appendix 3	4. Clarification of Fall arrest system at Cooling Tower	9 Nov 2018 (by email)	Appendix 4	5. Window Wall WW4 (N-RH) 3/F layout change	19 Sep 2018 (comment on WW4 shopdrawing SD(A) 308 by email)	Appendix 5	6. Clarification of E6 Entrance	22 Oct 2018 and 31 Oct 2018 (Reply to RFI/A/619)	Appendix 6	7. Clarification of rainwater downpipe and gutter for Window Wall WW3 canopy	31 Oct 2018 (by email)	Appendix 7	
Item	Date of information / confirmation conveyed to COBC via email	Remark																								
1. Fritted pattern on glass cladding GC1 at Ice Rink	28 Sep 2018 (Reply to RFI/A/504)	Appendix 1																								
2. Confirmation of mullion colour for window wall WW1, WW2, WW3 and WW4 to Dark Grey colour	20 Jul 2018 (at Façade meeting with MTR)	Appendix 2																								
3. Confirmation of 4 colours for Cooling Tower Louvre	19 Sep 2018 (by email)	Appendix 3																								
4. Clarification of Fall arrest system at Cooling Tower	9 Nov 2018 (by email)	Appendix 4																								
5. Window Wall WW4 (N-RH) 3/F layout change	19 Sep 2018 (comment on WW4 shopdrawing SD(A) 308 by email)	Appendix 5																								
6. Clarification of E6 Entrance	22 Oct 2018 and 31 Oct 2018 (Reply to RFI/A/619)	Appendix 6																								
7. Clarification of rainwater downpipe and gutter for Window Wall WW3 canopy	31 Oct 2018 (by email)	Appendix 7																								

Copies to :

<input checked="" type="checkbox"/> Contractor	/COBC	<input checked="" type="checkbox"/> Client	/WPL	<input checked="" type="checkbox"/> Client	/MTR	<input checked="" type="checkbox"/> Architect	/P&T
<input checked="" type="checkbox"/> RE / COW		<input checked="" type="checkbox"/> QS	/LS	<input checked="" type="checkbox"/> Engineer	/ARUP	<input checked="" type="checkbox"/> EM Engineer	/MME
<input checked="" type="checkbox"/> Landscape	ADI	<input checked="" type="checkbox"/> Interior	CL3	<input checked="" type="checkbox"/> Facade	/MFT	<input checked="" type="checkbox"/> Environ.& Safety Engineer	/PBA

* with enclosure

Issued by : Tony Chow
for P&T Architects and Engineers Ltd

Authorised by : Angus Chan
for P&T Architects and Engineers Ltd