



工程指示 / 要求簡箋(E.I.)

工程指示編號：EI 7549 修改版次：  
 工程編號：J835 工程名稱：TKO 66D 平台  
 工程項目：鋁棚板 - 確認鋁板加工圖紙 (TYPE B)  
 收件人：汪志光 發件人：Eddie 日期：2017.5.19

- 要求提供 / □確認 事項：
- |                                    |                                     |                               |
|------------------------------------|-------------------------------------|-------------------------------|
| <input type="checkbox"/> 初步鋁料 B.M. | <input type="checkbox"/> 加工拆圖，然後生產  | <input type="checkbox"/> 尺寸表  |
| <input type="checkbox"/> 正式鋁料 B.M. | <input type="checkbox"/> 技術上資料 / 指示 | <input type="checkbox"/> 報價   |
| <input type="checkbox"/> 配件 B.M.   | <input type="checkbox"/> 樣辦或貨品說明書   | <input type="checkbox"/> 分判合約 |
- (x) 其他：鋁板加工圖紙

內容：請將附頁加工圖紙加工，須按期完成。

請在 2017 5 月 前完成上列要求。

附有關圖紙 / 文件：

1+ 7頁

以上項目為：

- 原合約工程包     
  原合約工程加 / 減賬     
  新工程報價

原因：-

分發東莞各部門：

- 生產技術總監 □連附件   
  技術部 □連附件   
  生產部 □連附件   
  機械設計部 □連附件  
 採購部 □連附件   
 生產統籌部 □連附件  
 質檢部 □連附件   
 會計部 □連附件   
 報關組 □連附件   
 其他 \_\_\_\_\_ □連附件

分發香港各部門：

- 行政部 □連附件   
 會計部 □連附件   
 統籌部 □連附件   
 工程部地盤科文 □連附件  
 採購部 □連附件   
 QS 部 □連附件   
 維修部 □連附件   
 其他 \_\_\_\_\_ □連附件

傳遞編號：

HK 1636 (FTP)

發件人簽署：

項目經理簽署：

工程號: J-835 計算: 夏之川

日期: 18/5/2017

送呈:

地盤名稱: 新運商場

核對:

日期:

副本:

廠用鋁板B.M.表

項目類別: 鋁格

批准:

日期:

B/M編號:

修改版次: A/C Code:

總V.F.:

17.072

總重量:

137.97

此BM依據 資料計算

序號	修改內容	鋁板圖號	鋁板名稱	顏色	實用	後備	總數	總重量	單件展開面積		總展開面積		備註
									平方米	平方米	平方米	平方米	
1		835-SP60-B1	3mm厚鋁板	PPG UCT260655SC-3 3 Coats Bronze	1		1	1.395	0.172	0.172	0.172	0.172	
2		835-SP60-B2	3mm厚鋁板	PPG UCT260655SC-3 3 Coats Bronze	1		1	1.395	0.172	0.172	0.172	0.172	
3		835-SP61-B1	3mm厚鋁板	PPG UCT260655SC-3 3 Coats Bronze	3		3	2.541	0.104	0.313	0.104	0.313	
4		835-SP61-B2	3mm厚鋁板	PPG UCT260655SC-3 3 Coats Bronze	3		3	2.541	0.104	0.313	0.104	0.313	
5		835-SP62-B1	3mm厚鋁板	PPG UCT260655SC-3 3 Coats Bronze	1		1	0.716	0.088	0.088	0.088	0.088	
6		835-SP62-B2	3mm厚鋁板	PPG UCT260655SC-3 3 Coats Bronze	1		1	5.633	0.693	0.693	0.693	0.693	
7		835-SP63-B1	3mm厚鋁板	PPG UCT260655SC-3 3 Coats Bronze	1		1	0.971	0.119	0.119	0.119	0.119	
8		835-SP63-B2	3mm厚鋁板	PPG UCT260655SC-3 3 Coats Bronze	1		1	7.641	0.940	0.940	0.940	0.940	
9		835-SP64-B1	3mm厚鋁板	PPG UCT260655SC-3 3 Coats Bronze	1		1	0.415	0.051	0.051	0.051	0.051	
10		835-SP64-B2	3mm厚鋁板	PPG UCT260655SC-3 3 Coats Bronze	1		1	3.090	0.380	0.380	0.380	0.380	
11		835-SP65-B1	3mm厚鋁板	PPG UCT260655SC-3 3 Coats Bronze	1		1	0.604	0.074	0.074	0.074	0.074	
12		835-SP65-B2	3mm厚鋁板	PPG UCT260655SC-3 3 Coats Bronze	1		1	4.504	0.554	0.554	0.554	0.554	
13		835-SP66-B1	3mm厚鋁板	PPG UCT260655SC-3 3 Coats Bronze	1		1	0.474	0.058	0.058	0.058	0.058	
14		835-SP66-B2	3mm厚鋁板	PPG UCT260655SC-3 3 Coats Bronze	1		1	3.535	0.435	0.435	0.435	0.435	
15		835-SP67-B1	3mm厚鋁板	PPG UCT260655SC-3 3 Coats Bronze	1		1	0.412	0.051	0.051	0.051	0.051	
16		835-SP67-B2	3mm厚鋁板	PPG UCT260655SC-3 3 Coats Bronze	1		1	3.068	0.377	0.377	0.377	0.377	
17		835-SP68-B1	3mm厚鋁板	PPG UCT260655SC-3 3 Coats Bronze	2		2	0.737	0.045	0.091	0.045	0.091	
18		835-SP68-B2	3mm厚鋁板	PPG UCT260655SC-3 3 Coats Bronze	2		2	5.496	0.338	0.676	0.338	0.676	

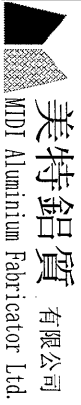

美特鋁質 有限公司  
MDT Aluminium Fabricator Ltd

廠用鋁板B.M.表

工程號: J-835 計算: 夏之川  
地盤名稱: 將軍澳 核對:  
項目類別: 鋁格 批准:  
修改版次: A/C Code:

日期: 18/5/2017  
日期:  
日期:  
日期:  
總V.F.: 17.072 總重量: 137.97  
此BM依據 資料計算

序號	修改內容	鋁板圖號	鋁板名稱	顏色	實用	後備	總數	總重量	平方米		平方米		備註
									單件展 開面積	總展開 面積	單件V.F.	總V.F.	
19		835-SP69-B1	3mm厚鋁板	PPG UCT260655SC-3 3 Coats Bronze	1		1	0.326	0.040	0.040	0.040	0.040	
20		835-SP69-B2	3mm厚鋁板	PPG UCT260655SC-3 3 Coats Bronze	1		1	2.427	0.299	0.299	0.299	0.299	
21		835-SP70-B1	3mm厚鋁板	PPG UCT260655SC-3 3 Coats Bronze	1		1	0.561	0.069	0.069	0.069	0.069	
22		835-SP70-B2	3mm厚鋁板	PPG UCT260655SC-3 3 Coats Bronze	1		1	4.184	0.515	0.515	0.515	0.515	
23		835-SP71-B1	3mm厚鋁板	PPG UCT260655SC-3 3 Coats Bronze	1		1	1.004	0.123	0.123	0.123	0.123	
24		835-SP71-B2	3mm厚鋁板	PPG UCT260655SC-3 3 Coats Bronze	1		1	7.485	0.921	0.921	0.921	0.921	
25		835-SP72-B1	3mm厚鋁板	PPG UCT260655SC-3 3 Coats Bronze	1		1	1.067	0.131	0.131	0.131	0.131	
26		835-SP72-B2	3mm厚鋁板	PPG UCT260655SC-3 3 Coats Bronze	1		1	7.952	0.978	0.978	0.978	0.978	
27		835-SP73-B1	3mm厚鋁板	PPG UCT260655SC-3 3 Coats Bronze	1		1	6.243	0.768	0.768	0.768	0.768	
28		835-SP73-B2	3mm厚鋁板	PPG UCT260655SC-3 3 Coats Bronze	1		1	0.106	0.013	0.013	0.013	0.013	
29		835-SP74-B1	3mm厚鋁板	PPG UCT260655SC-3 3 Coats Bronze	1		1	8.469	1.042	1.042	1.042	1.042	
30		835-SP74-B2	3mm厚鋁板	PPG UCT260655SC-3 3 Coats Bronze	1		1	0.143	0.018	0.018	0.018	0.018	
31		835-SP75-B1	3mm厚鋁板	PPG UCT260655SC-3 3 Coats Bronze	1		1	3.444	0.424	0.424	0.424	0.424	
32		835-SP75-B2	3mm厚鋁板	PPG UCT260655SC-3 3 Coats Bronze	1		1	0.061	0.008	0.008	0.008	0.008	
33		835-SP76-B1	3mm厚鋁板	PPG UCT260655SC-3 3 Coats Bronze	1		1	5.019	0.617	0.617	0.617	0.617	
34		835-SP76-B2	3mm厚鋁板	PPG UCT260655SC-3 3 Coats Bronze	1		1	0.089	0.011	0.011	0.011	0.011	
35		835-SP77-B1	3mm厚鋁板	PPG UCT260655SC-3 3 Coats Bronze	1		1	3.939	0.485	0.485	0.485	0.485	
36		835-SP77-B2	3mm厚鋁板	PPG UCT260655SC-3 3 Coats Bronze	1		1	0.070	0.009	0.009	0.009	0.009	

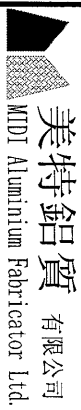

美特鋁質 有限公司  
MTDI Aluminium Fabricator Ltd.

工程號: J-835 計算: 夏之川

日期: 18/5/2017

送呈:

地盤名稱: 將軍澳 核對:

日期:

副本:

廠用鋁板B.M.表

項目類別: 鋁格 批准:

日期:

B.M.編號:

修改版次: A/C Code:

總V.F.:

17.072

總重量: 137.97

此B.M.依據 資料計算

序號	修改內容	鋁板圖號	鋁板名稱	顏色	實用	後備	總數	總重量	單件展開面積		單件V.F.	總V.F.	備註
									平方米	平方米			
37		835-SP78-B1	3mm厚鋁板	PPG UCT260655SC-3 3 Coats Bronze	1		1	3.419	0.421	0.421	0.421	0.421	
38		835-SP78-B2	3mm厚鋁板	PPG UCT260655SC-3 3 Coats Bronze	1		1	0.061	0.007	0.007	0.007	0.007	
39		835-SP79-B1	3mm厚鋁板	PPG UCT260655SC-3 3 Coats Bronze	2		2	6.124	0.377	0.753	0.377	0.753	
40		835-SP79-B2	3mm厚鋁板	PPG UCT260655SC-3 3 Coats Bronze	2		2	0.109	0.007	0.013	0.007	0.013	
41		835-SP80-B1	3mm厚鋁板	PPG UCT260655SC-3 3 Coats Bronze	1		1	2.705	0.333	0.333	0.333	0.333	
42		835-SP80-B2	3mm厚鋁板	PPG UCT260655SC-3 3 Coats Bronze	1		1	0.048	0.006	0.006	0.006	0.006	
43		835-SP81-B1	3mm厚鋁板	PPG UCT260655SC-3 3 Coats Bronze	1		1	4.662	0.573	0.573	0.573	0.573	
44		835-SP81-B2	3mm厚鋁板	PPG UCT260655SC-3 3 Coats Bronze	1		1	0.083	0.010	0.010	0.010	0.010	
45		835-SP82-B1	3mm厚鋁板	PPG UCT260655SC-3 3 Coats Bronze	1		1	8.341	1.026	1.026	1.026	1.026	
46		835-SP82-B2	3mm厚鋁板	PPG UCT260655SC-3 3 Coats Bronze	1		1	0.148	0.018	0.018	0.018	0.018	
47		835-SP83-B1	3mm厚鋁板	PPG UCT260655SC-3 3 Coats Bronze	1		1	8.861	1.090	1.090	1.090	1.090	
48		835-SP83-B2	3mm厚鋁板	PPG UCT260655SC-3 3 Coats Bronze	1		1	0.157	0.019	0.019	0.019	0.019	
49		835-VL-C1	3mm厚鋁板	PPG UCT260655SC-3 3 Coats Bronze	120		120	2.341	0.002	0.288	0.003	0.331	
50		835-VL-C1R	3mm厚鋁板	PPG UCT260655SC-3 3 Coats Bronze	120		120	2.341	0.002	0.288	0.003	0.331	
51		835-VL-C2	3mm厚鋁板	PPG UCT260655SC-3 3 Coats Bronze	50		50	0.407	0.001	0.050	0.001	0.058	
52		835-VL-C2R	3mm厚鋁板	PPG UCT260655SC-3 3 Coats Bronze	50		50	0.407	0.001	0.050	0.001	0.058	
					合計:		396	137.97		16.970		17.072	



 美特鋁質 有限公司 MIDI Aluminium Fabricator Ltd.				類別		物料號		
				制圖	夏之川	2017.05.18	圖號	835-B1A
修改				復核			數量	
日期				批准			位置	

数据表见：835-B1A-10

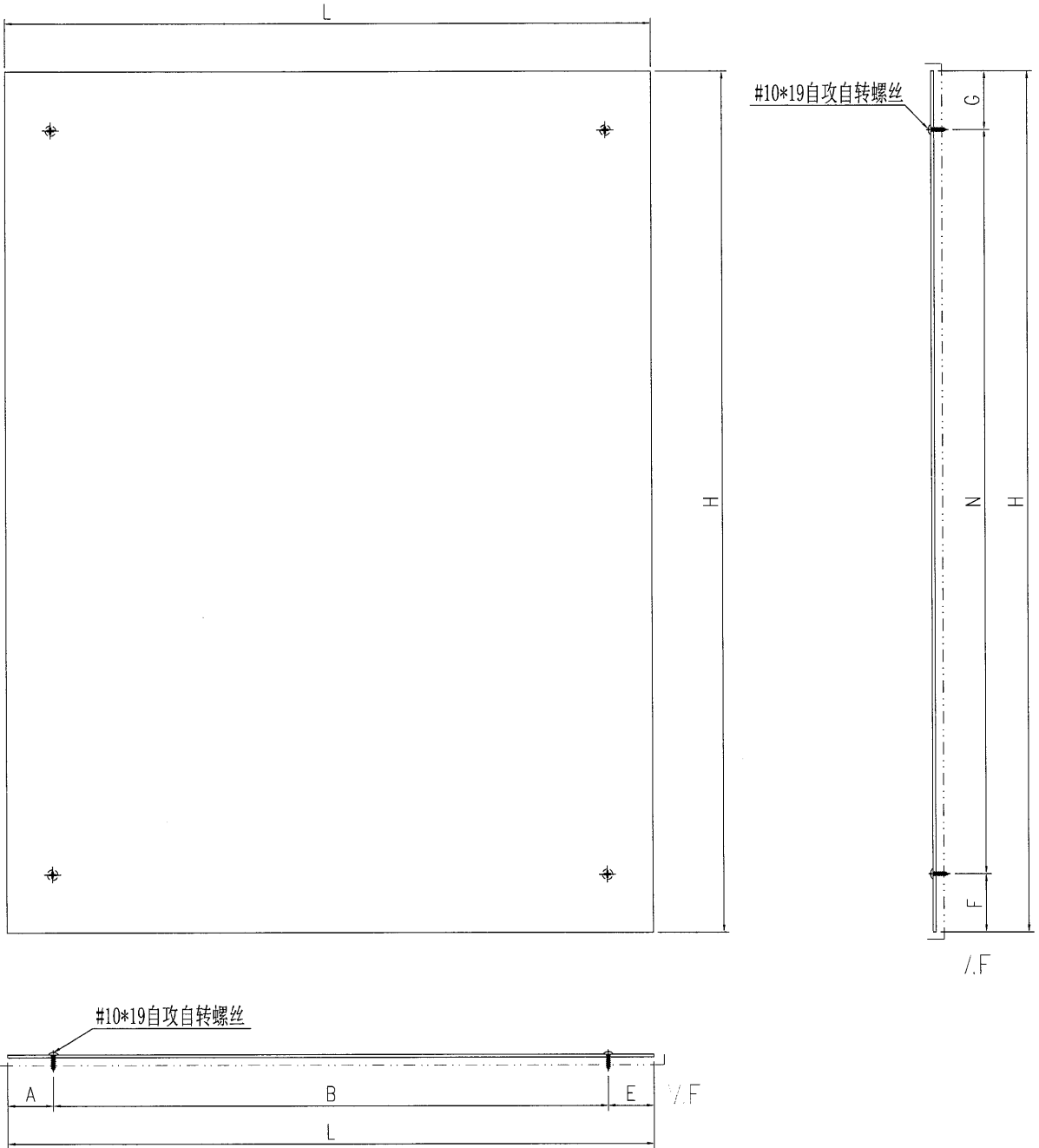

工程號	J-835	地盤	天晉平臺	附件
名稱	鋁背板加工圖		採用	
材料	3mm鋁板		地盤	
顏色	PPG UCT26065SC-3 3 Coats Bronze		工廠	

 美特鋁質 有限公司 MIDI Aluminium Fabricator Ltd.				類別		物料號																																																																																																																																																																																																																																																																																																																																																																																																																																																																																																																																																																																																																	
				制圖		夏之川		2017.05.18		圖號 835-B1A-10																																																																																																																																																																																																																																																																																																																																																																																																																																																																																																																																																																																																													
修改				復核				數量		見表																																																																																																																																																																																																																																																																																																																																																																																																																																																																																																																																																																																																													
日期				批准				位置																																																																																																																																																																																																																																																																																																																																																																																																																																																																																																																																																																																																															
<table border="1"> <thead> <tr> <th>物料編號</th> <th>數量</th> <th>L</th> <th>A</th> <th colspan="2">B</th> <th>E</th> <th>H</th> <th>F</th> <th colspan="2">N</th> <th>G</th> </tr> </thead> <tbody> <tr><td>835-SP60-B1</td><td>1</td><td>2469.5</td><td>120</td><td>7</td><td>x</td><td>300</td><td>249.5</td><td>69.5</td><td>30</td><td>0</td><td>39.5</td></tr> <tr><td>835-SP60-B2</td><td>1</td><td>2469.5</td><td>120</td><td>7</td><td>x</td><td>300</td><td>249.5</td><td>69.5</td><td>30</td><td>0</td><td>39.5</td></tr> <tr><td>835-SP61-B1</td><td>3</td><td>1499</td><td>149.5</td><td>4</td><td>x</td><td>300</td><td>149.5</td><td>69.5</td><td>30</td><td>0</td><td>39.5</td></tr> <tr><td>835-SP61-B2</td><td>3</td><td>1499</td><td>149.5</td><td>4</td><td>x</td><td>300</td><td>149.5</td><td>69.5</td><td>30</td><td>0</td><td>39.5</td></tr> <tr><td>835-SP62-B1</td><td>1</td><td>366</td><td>33</td><td>1</td><td>x</td><td>300</td><td>33</td><td>240.5</td><td>50</td><td>150</td><td>40.5</td></tr> <tr><td>835-SP62-B2</td><td>1</td><td>366</td><td>33</td><td>1</td><td>x</td><td>300</td><td>33</td><td>1893</td><td>50</td><td>6 x 300</td><td>43</td></tr> <tr><td>835-SP63-B1</td><td>1</td><td>496.5</td><td>82</td><td>1</td><td>x</td><td>300</td><td>114.5</td><td>240.5</td><td>50</td><td>150</td><td>40.5</td></tr> <tr><td>835-SP63-B2</td><td>1</td><td>496.5</td><td>82</td><td>1</td><td>x</td><td>300</td><td>114.5</td><td>1893</td><td>50</td><td>6 x 300</td><td>43</td></tr> <tr><td>835-SP64-B1</td><td>1</td><td>212</td><td>73</td><td>1</td><td>x</td><td>100</td><td>39</td><td>240.5</td><td>50</td><td>150</td><td>40.5</td></tr> <tr><td>835-SP64-B2</td><td>1</td><td>212</td><td>73</td><td>1</td><td>x</td><td>100</td><td>39</td><td>1793</td><td>50</td><td>5 x 300</td><td>243</td></tr> <tr><td>835-SP65-B1</td><td>1</td><td>309</td><td>44</td><td>1</td><td>x</td><td>200</td><td>65</td><td>240.5</td><td>50</td><td>150</td><td>40.5</td></tr> <tr><td>835-SP65-B2</td><td>1</td><td>309</td><td>44</td><td>1</td><td>x</td><td>200</td><td>65</td><td>1793</td><td>50</td><td>5 x 300</td><td>243</td></tr> <tr><td>835-SP66-B1</td><td>1</td><td>242.5</td><td>22.5</td><td>1</td><td>x</td><td>200</td><td>20</td><td>240.5</td><td>50</td><td>150</td><td>40.5</td></tr> <tr><td>835-SP66-B2</td><td>1</td><td>242.5</td><td>22.5</td><td>1</td><td>x</td><td>200</td><td>20</td><td>1793</td><td>50</td><td>5 x 300</td><td>243</td></tr> <tr><td>835-SP67-B1</td><td>1</td><td>210.5</td><td>67</td><td>1</td><td>x</td><td>100</td><td>43.5</td><td>240.5</td><td>50</td><td>150</td><td>40.5</td></tr> <tr><td>835-SP67-B2</td><td>1</td><td>210.5</td><td>67</td><td>1</td><td>x</td><td>100</td><td>43.5</td><td>1793</td><td>50</td><td>5 x 300</td><td>243</td></tr> <tr><td>835-SP68-B1</td><td>2</td><td>188.5</td><td>45</td><td>1</td><td>x</td><td>100</td><td>43.5</td><td>240.5</td><td>50</td><td>150</td><td>40.5</td></tr> <tr><td>835-SP68-B2</td><td>2</td><td>188.5</td><td>45</td><td>1</td><td>x</td><td>100</td><td>43.5</td><td>1793</td><td>50</td><td>5 x 300</td><td>243</td></tr> <tr><td>835-SP69-B1</td><td>1</td><td>166.5</td><td>45</td><td>1</td><td>x</td><td>100</td><td>21.5</td><td>240.5</td><td>50</td><td>150</td><td>40.5</td></tr> <tr><td>835-SP69-B2</td><td>1</td><td>166.5</td><td>45</td><td>1</td><td>x</td><td>100</td><td>21.5</td><td>1793</td><td>50</td><td>5 x 300</td><td>243</td></tr> <tr><td>835-SP70-B1</td><td>1</td><td>287</td><td>44</td><td>1</td><td>x</td><td>200</td><td>43</td><td>240.5</td><td>50</td><td>150</td><td>40.5</td></tr> <tr><td>835-SP70-B2</td><td>1</td><td>287</td><td>44</td><td>1</td><td>x</td><td>200</td><td>43</td><td>1793</td><td>50</td><td>5 x 300</td><td>243</td></tr> <tr><td>835-SP71-B1</td><td>1</td><td>513.5</td><td>51</td><td>2</td><td>x</td><td>200</td><td>62.5</td><td>240.5</td><td>50</td><td>150</td><td>40.5</td></tr> <tr><td>835-SP71-B2</td><td>1</td><td>513.5</td><td>51</td><td>2</td><td>x</td><td>200</td><td>62.5</td><td>1793</td><td>50</td><td>5 x 300</td><td>243</td></tr> <tr><td>835-SP72-B1</td><td>1</td><td>545.5</td><td>26</td><td>2</td><td>x</td><td>250</td><td>19.5</td><td>240.5</td><td>50</td><td>150</td><td>40.5</td></tr> <tr><td>835-SP72-B2</td><td>1</td><td>545.5</td><td>26</td><td>2</td><td>x</td><td>250</td><td>19.5</td><td>1793</td><td>50</td><td>5 x 300</td><td>243</td></tr> <tr><td>835-SP73-B1</td><td>1</td><td>366</td><td>33</td><td>1</td><td>x</td><td>300</td><td>33</td><td>2098</td><td>50</td><td>6 x 300</td><td>248</td></tr> <tr><td>835-SP73-B2</td><td>1</td><td>366</td><td>33</td><td>1</td><td>x</td><td>300</td><td>33</td><td>35.5</td><td>15</td><td>0</td><td>20.5</td></tr> <tr><td>835-SP74-B1</td><td>1</td><td>496.5</td><td>82</td><td>1</td><td>x</td><td>300</td><td>114.5</td><td>2098</td><td>50</td><td>6 x 300</td><td>248</td></tr> <tr><td>835-SP74-B2</td><td>1</td><td>496.5</td><td>82</td><td>1</td><td>x</td><td>300</td><td>114.5</td><td>35.5</td><td>15</td><td>0</td><td>20.5</td></tr> <tr><td>835-SP75-B1</td><td>1</td><td>212</td><td>73</td><td>1</td><td>x</td><td>100</td><td>39</td><td>1998</td><td>50</td><td>6 x 300</td><td>148</td></tr> <tr><td>835-SP75-B2</td><td>1</td><td>212</td><td>73</td><td>1</td><td>x</td><td>100</td><td>39</td><td>35.5</td><td>15</td><td>0</td><td>20.5</td></tr> <tr><td>835-SP76-B1</td><td>1</td><td>309</td><td>44</td><td>1</td><td>x</td><td>200</td><td>65</td><td>1998</td><td>50</td><td>6 x 300</td><td>148</td></tr> <tr><td>835-SP76-B2</td><td>1</td><td>309</td><td>44</td><td>1</td><td>x</td><td>200</td><td>65</td><td>35.5</td><td>15</td><td>0</td><td>20.5</td></tr> <tr><td>835-SP77-B1</td><td>1</td><td>242.5</td><td>22.5</td><td>1</td><td>x</td><td>200</td><td>20</td><td>1998</td><td>50</td><td>6 x 300</td><td>148</td></tr> <tr><td>835-SP77-B2</td><td>1</td><td>242.5</td><td>22.5</td><td>1</td><td>x</td><td>200</td><td>20</td><td>35.5</td><td>15</td><td>0</td><td>20.5</td></tr> <tr><td>835-SP78-B1</td><td>1</td><td>210.5</td><td>67</td><td>1</td><td>x</td><td>100</td><td>43.5</td><td>1998</td><td>50</td><td>6 x 300</td><td>148</td></tr> <tr><td>835-SP78-B2</td><td>1</td><td>210.5</td><td>67</td><td>1</td><td>x</td><td>100</td><td>43.5</td><td>35.5</td><td>15</td><td>0</td><td>20.5</td></tr> <tr><td>835-SP79-B1</td><td>2</td><td>188.5</td><td>45</td><td>1</td><td>x</td><td>100</td><td>43.5</td><td>1998</td><td>50</td><td>6 x 300</td><td>148</td></tr> <tr><td>835-SP79-B2</td><td>2</td><td>188.5</td><td>45</td><td>1</td><td>x</td><td>100</td><td>43.5</td><td>35.5</td><td>15</td><td>0</td><td>20.5</td></tr> <tr><td>835-SP80-B1</td><td>1</td><td>166.5</td><td>45</td><td>1</td><td>x</td><td>100</td><td>21.5</td><td>1998</td><td>50</td><td>6 x 300</td><td>148</td></tr> <tr><td>835-SP80-B2</td><td>1</td><td>166.5</td><td>45</td><td>1</td><td>x</td><td>100</td><td>21.5</td><td>35.5</td><td>15</td><td>0</td><td>20.5</td></tr> <tr><td>835-SP81-B1</td><td>1</td><td>287</td><td>44</td><td>1</td><td>x</td><td>200</td><td>43</td><td>1998</td><td>50</td><td>6 x 300</td><td>148</td></tr> <tr><td>835-SP81-B2</td><td>1</td><td>287</td><td>44</td><td>1</td><td>x</td><td>200</td><td>43</td><td>35.5</td><td>15</td><td>0</td><td>20.5</td></tr> <tr><td>835-SP82-B1</td><td>1</td><td>513.5</td><td>51</td><td>2</td><td>x</td><td>200</td><td>62.5</td><td>1998</td><td>50</td><td>6 x 300</td><td>148</td></tr> <tr><td>835-SP82-B2</td><td>1</td><td>513.5</td><td>51</td><td>2</td><td>x</td><td>200</td><td>62.5</td><td>35.5</td><td>15</td><td>0</td><td>20.5</td></tr> <tr><td>835-SP83-B1</td><td>1</td><td>545.5</td><td>26</td><td>2</td><td>x</td><td>250</td><td>19.5</td><td>1998</td><td>50</td><td>6 x 300</td><td>148</td></tr> <tr><td>835-SP83-B2</td><td>1</td><td>545.5</td><td>26</td><td>2</td><td>x</td><td>250</td><td>19.5</td><td>35.5</td><td>15</td><td>0</td><td>20.5</td></tr> </tbody> </table>												物料編號	數量	L	A	B		E	H	F	N		G	835-SP60-B1	1	2469.5	120	7	x	300	249.5	69.5	30	0	39.5	835-SP60-B2	1	2469.5	120	7	x	300	249.5	69.5	30	0	39.5	835-SP61-B1	3	1499	149.5	4	x	300	149.5	69.5	30	0	39.5	835-SP61-B2	3	1499	149.5	4	x	300	149.5	69.5	30	0	39.5	835-SP62-B1	1	366	33	1	x	300	33	240.5	50	150	40.5	835-SP62-B2	1	366	33	1	x	300	33	1893	50	6 x 300	43	835-SP63-B1	1	496.5	82	1	x	300	114.5	240.5	50	150	40.5	835-SP63-B2	1	496.5	82	1	x	300	114.5	1893	50	6 x 300	43	835-SP64-B1	1	212	73	1	x	100	39	240.5	50	150	40.5	835-SP64-B2	1	212	73	1	x	100	39	1793	50	5 x 300	243	835-SP65-B1	1	309	44	1	x	200	65	240.5	50	150	40.5	835-SP65-B2	1	309	44	1	x	200	65	1793	50	5 x 300	243	835-SP66-B1	1	242.5	22.5	1	x	200	20	240.5	50	150	40.5	835-SP66-B2	1	242.5	22.5	1	x	200	20	1793	50	5 x 300	243	835-SP67-B1	1	210.5	67	1	x	100	43.5	240.5	50	150	40.5	835-SP67-B2	1	210.5	67	1	x	100	43.5	1793	50	5 x 300	243	835-SP68-B1	2	188.5	45	1	x	100	43.5	240.5	50	150	40.5	835-SP68-B2	2	188.5	45	1	x	100	43.5	1793	50	5 x 300	243	835-SP69-B1	1	166.5	45	1	x	100	21.5	240.5	50	150	40.5	835-SP69-B2	1	166.5	45	1	x	100	21.5	1793	50	5 x 300	243	835-SP70-B1	1	287	44	1	x	200	43	240.5	50	150	40.5	835-SP70-B2	1	287	44	1	x	200	43	1793	50	5 x 300	243	835-SP71-B1	1	513.5	51	2	x	200	62.5	240.5	50	150	40.5	835-SP71-B2	1	513.5	51	2	x	200	62.5	1793	50	5 x 300	243	835-SP72-B1	1	545.5	26	2	x	250	19.5	240.5	50	150	40.5	835-SP72-B2	1	545.5	26	2	x	250	19.5	1793	50	5 x 300	243	835-SP73-B1	1	366	33	1	x	300	33	2098	50	6 x 300	248	835-SP73-B2	1	366	33	1	x	300	33	35.5	15	0	20.5	835-SP74-B1	1	496.5	82	1	x	300	114.5	2098	50	6 x 300	248	835-SP74-B2	1	496.5	82	1	x	300	114.5	35.5	15	0	20.5	835-SP75-B1	1	212	73	1	x	100	39	1998	50	6 x 300	148	835-SP75-B2	1	212	73	1	x	100	39	35.5	15	0	20.5	835-SP76-B1	1	309	44	1	x	200	65	1998	50	6 x 300	148	835-SP76-B2	1	309	44	1	x	200	65	35.5	15	0	20.5	835-SP77-B1	1	242.5	22.5	1	x	200	20	1998	50	6 x 300	148	835-SP77-B2	1	242.5	22.5	1	x	200	20	35.5	15	0	20.5	835-SP78-B1	1	210.5	67	1	x	100	43.5	1998	50	6 x 300	148	835-SP78-B2	1	210.5	67	1	x	100	43.5	35.5	15	0	20.5	835-SP79-B1	2	188.5	45	1	x	100	43.5	1998	50	6 x 300	148	835-SP79-B2	2	188.5	45	1	x	100	43.5	35.5	15	0	20.5	835-SP80-B1	1	166.5	45	1	x	100	21.5	1998	50	6 x 300	148	835-SP80-B2	1	166.5	45	1	x	100	21.5	35.5	15	0	20.5	835-SP81-B1	1	287	44	1	x	200	43	1998	50	6 x 300	148	835-SP81-B2	1	287	44	1	x	200	43	35.5	15	0	20.5	835-SP82-B1	1	513.5	51	2	x	200	62.5	1998	50	6 x 300	148	835-SP82-B2	1	513.5	51	2	x	200	62.5	35.5	15	0	20.5	835-SP83-B1	1	545.5	26	2	x	250	19.5	1998	50	6 x 300	148	835-SP83-B2	1	545.5	26	2	x	250	19.5	35.5	15	0	20.5
物料編號	數量	L	A	B		E	H	F	N		G																																																																																																																																																																																																																																																																																																																																																																																																																																																																																																																																																																																																												
835-SP60-B1	1	2469.5	120	7	x	300	249.5	69.5	30	0	39.5																																																																																																																																																																																																																																																																																																																																																																																																																																																																																																																																																																																																												
835-SP60-B2	1	2469.5	120	7	x	300	249.5	69.5	30	0	39.5																																																																																																																																																																																																																																																																																																																																																																																																																																																																																																																																																																																																												
835-SP61-B1	3	1499	149.5	4	x	300	149.5	69.5	30	0	39.5																																																																																																																																																																																																																																																																																																																																																																																																																																																																																																																																																																																																												
835-SP61-B2	3	1499	149.5	4	x	300	149.5	69.5	30	0	39.5																																																																																																																																																																																																																																																																																																																																																																																																																																																																																																																																																																																																												
835-SP62-B1	1	366	33	1	x	300	33	240.5	50	150	40.5																																																																																																																																																																																																																																																																																																																																																																																																																																																																																																																																																																																																												
835-SP62-B2	1	366	33	1	x	300	33	1893	50	6 x 300	43																																																																																																																																																																																																																																																																																																																																																																																																																																																																																																																																																																																																												
835-SP63-B1	1	496.5	82	1	x	300	114.5	240.5	50	150	40.5																																																																																																																																																																																																																																																																																																																																																																																																																																																																																																																																																																																																												
835-SP63-B2	1	496.5	82	1	x	300	114.5	1893	50	6 x 300	43																																																																																																																																																																																																																																																																																																																																																																																																																																																																																																																																																																																																												
835-SP64-B1	1	212	73	1	x	100	39	240.5	50	150	40.5																																																																																																																																																																																																																																																																																																																																																																																																																																																																																																																																																																																																												
835-SP64-B2	1	212	73	1	x	100	39	1793	50	5 x 300	243																																																																																																																																																																																																																																																																																																																																																																																																																																																																																																																																																																																																												
835-SP65-B1	1	309	44	1	x	200	65	240.5	50	150	40.5																																																																																																																																																																																																																																																																																																																																																																																																																																																																																																																																																																																																												
835-SP65-B2	1	309	44	1	x	200	65	1793	50	5 x 300	243																																																																																																																																																																																																																																																																																																																																																																																																																																																																																																																																																																																																												
835-SP66-B1	1	242.5	22.5	1	x	200	20	240.5	50	150	40.5																																																																																																																																																																																																																																																																																																																																																																																																																																																																																																																																																																																																												
835-SP66-B2	1	242.5	22.5	1	x	200	20	1793	50	5 x 300	243																																																																																																																																																																																																																																																																																																																																																																																																																																																																																																																																																																																																												
835-SP67-B1	1	210.5	67	1	x	100	43.5	240.5	50	150	40.5																																																																																																																																																																																																																																																																																																																																																																																																																																																																																																																																																																																																												
835-SP67-B2	1	210.5	67	1	x	100	43.5	1793	50	5 x 300	243																																																																																																																																																																																																																																																																																																																																																																																																																																																																																																																																																																																																												
835-SP68-B1	2	188.5	45	1	x	100	43.5	240.5	50	150	40.5																																																																																																																																																																																																																																																																																																																																																																																																																																																																																																																																																																																																												
835-SP68-B2	2	188.5	45	1	x	100	43.5	1793	50	5 x 300	243																																																																																																																																																																																																																																																																																																																																																																																																																																																																																																																																																																																																												
835-SP69-B1	1	166.5	45	1	x	100	21.5	240.5	50	150	40.5																																																																																																																																																																																																																																																																																																																																																																																																																																																																																																																																																																																																												
835-SP69-B2	1	166.5	45	1	x	100	21.5	1793	50	5 x 300	243																																																																																																																																																																																																																																																																																																																																																																																																																																																																																																																																																																																																												
835-SP70-B1	1	287	44	1	x	200	43	240.5	50	150	40.5																																																																																																																																																																																																																																																																																																																																																																																																																																																																																																																																																																																																												
835-SP70-B2	1	287	44	1	x	200	43	1793	50	5 x 300	243																																																																																																																																																																																																																																																																																																																																																																																																																																																																																																																																																																																																												
835-SP71-B1	1	513.5	51	2	x	200	62.5	240.5	50	150	40.5																																																																																																																																																																																																																																																																																																																																																																																																																																																																																																																																																																																																												
835-SP71-B2	1	513.5	51	2	x	200	62.5	1793	50	5 x 300	243																																																																																																																																																																																																																																																																																																																																																																																																																																																																																																																																																																																																												
835-SP72-B1	1	545.5	26	2	x	250	19.5	240.5	50	150	40.5																																																																																																																																																																																																																																																																																																																																																																																																																																																																																																																																																																																																												
835-SP72-B2	1	545.5	26	2	x	250	19.5	1793	50	5 x 300	243																																																																																																																																																																																																																																																																																																																																																																																																																																																																																																																																																																																																												
835-SP73-B1	1	366	33	1	x	300	33	2098	50	6 x 300	248																																																																																																																																																																																																																																																																																																																																																																																																																																																																																																																																																																																																												
835-SP73-B2	1	366	33	1	x	300	33	35.5	15	0	20.5																																																																																																																																																																																																																																																																																																																																																																																																																																																																																																																																																																																																												
835-SP74-B1	1	496.5	82	1	x	300	114.5	2098	50	6 x 300	248																																																																																																																																																																																																																																																																																																																																																																																																																																																																																																																																																																																																												
835-SP74-B2	1	496.5	82	1	x	300	114.5	35.5	15	0	20.5																																																																																																																																																																																																																																																																																																																																																																																																																																																																																																																																																																																																												
835-SP75-B1	1	212	73	1	x	100	39	1998	50	6 x 300	148																																																																																																																																																																																																																																																																																																																																																																																																																																																																																																																																																																																																												
835-SP75-B2	1	212	73	1	x	100	39	35.5	15	0	20.5																																																																																																																																																																																																																																																																																																																																																																																																																																																																																																																																																																																																												
835-SP76-B1	1	309	44	1	x	200	65	1998	50	6 x 300	148																																																																																																																																																																																																																																																																																																																																																																																																																																																																																																																																																																																																												
835-SP76-B2	1	309	44	1	x	200	65	35.5	15	0	20.5																																																																																																																																																																																																																																																																																																																																																																																																																																																																																																																																																																																																												
835-SP77-B1	1	242.5	22.5	1	x	200	20	1998	50	6 x 300	148																																																																																																																																																																																																																																																																																																																																																																																																																																																																																																																																																																																																												
835-SP77-B2	1	242.5	22.5	1	x	200	20	35.5	15	0	20.5																																																																																																																																																																																																																																																																																																																																																																																																																																																																																																																																																																																																												
835-SP78-B1	1	210.5	67	1	x	100	43.5	1998	50	6 x 300	148																																																																																																																																																																																																																																																																																																																																																																																																																																																																																																																																																																																																												
835-SP78-B2	1	210.5	67	1	x	100	43.5	35.5	15	0	20.5																																																																																																																																																																																																																																																																																																																																																																																																																																																																																																																																																																																																												
835-SP79-B1	2	188.5	45	1	x	100	43.5	1998	50	6 x 300	148																																																																																																																																																																																																																																																																																																																																																																																																																																																																																																																																																																																																												
835-SP79-B2	2	188.5	45	1	x	100	43.5	35.5	15	0	20.5																																																																																																																																																																																																																																																																																																																																																																																																																																																																																																																																																																																																												
835-SP80-B1	1	166.5	45	1	x	100	21.5	1998	50	6 x 300	148																																																																																																																																																																																																																																																																																																																																																																																																																																																																																																																																																																																																												
835-SP80-B2	1	166.5	45	1	x	100	21.5	35.5	15	0	20.5																																																																																																																																																																																																																																																																																																																																																																																																																																																																																																																																																																																																												
835-SP81-B1	1	287	44	1	x	200	43	1998	50	6 x 300	148																																																																																																																																																																																																																																																																																																																																																																																																																																																																																																																																																																																																												
835-SP81-B2	1	287	44	1	x	200	43	35.5	15	0	20.5																																																																																																																																																																																																																																																																																																																																																																																																																																																																																																																																																																																																												
835-SP82-B1	1	513.5	51	2	x	200	62.5	1998	50	6 x 300	148																																																																																																																																																																																																																																																																																																																																																																																																																																																																																																																																																																																																												
835-SP82-B2	1	513.5	51	2	x	200	62.5	35.5	15	0	20.5																																																																																																																																																																																																																																																																																																																																																																																																																																																																																																																																																																																																												
835-SP83-B1	1	545.5	26	2	x	250	19.5	1998	50	6 x 300	148																																																																																																																																																																																																																																																																																																																																																																																																																																																																																																																																																																																																												
835-SP83-B2	1	545.5	26	2	x	250	19.5	35.5	15	0	20.5																																																																																																																																																																																																																																																																																																																																																																																																																																																																																																																																																																																																												
工程號	J-835	地盤	天晉平臺																																																																																																																																																																																																																																																																																																																																																																																																																																																																																																																																																																																																																				
名稱	數據表			探用								附 件																																																																																																																																																																																																																																																																																																																																																																																																																																																																																																																																																																																																											
材料				地盤																																																																																																																																																																																																																																																																																																																																																																																																																																																																																																																																																																																																																			
顏色				工廠																																																																																																																																																																																																																																																																																																																																																																																																																																																																																																																																																																																																																			

 美特鋁質 有限公司 MIDI Aluminium Fabricator Ltd.				類別		物料號	
修改				制圖	夏之川	2017.05.18	圖號 835-C1A
日期				復核			數量 -
				批准			位置

下

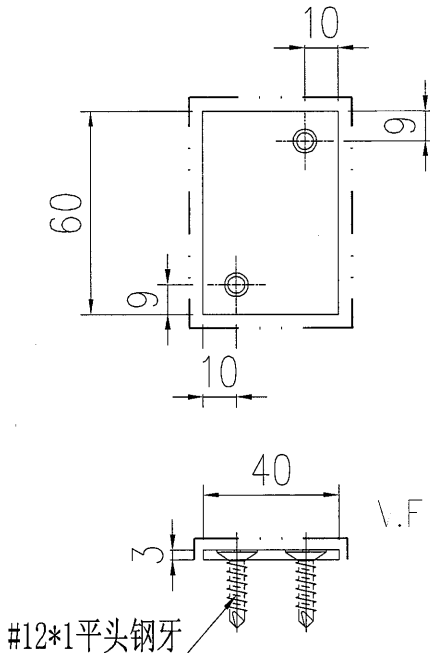

物料編號	數量
835-VL-C1R	120

上

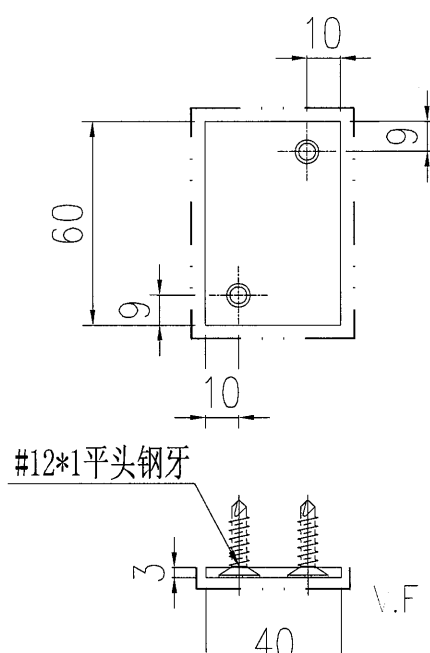

物料編號	數量
835-VL-C1	120

下

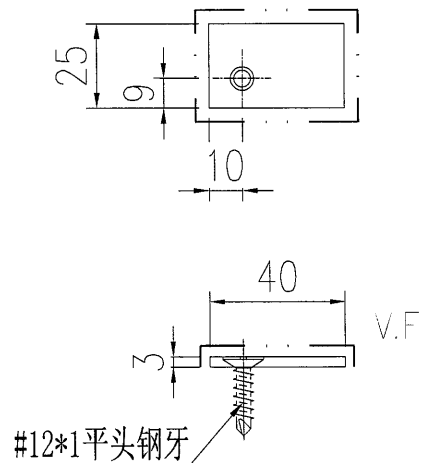

物料編號	數量
835-VL-C2R	50

上

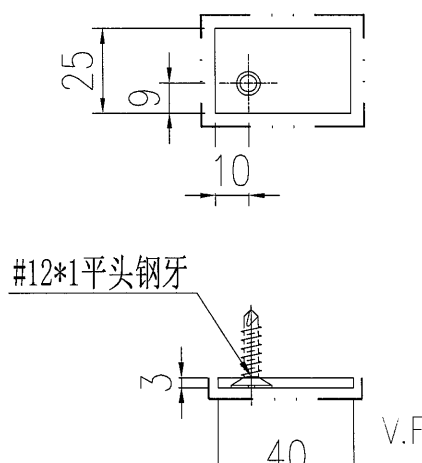

物料編號	數量
835-VL-C2	50

工程號	J-835	地盤	天晉平臺	附件
名稱	墊片加工圖		採用	
材料	3mm鋁巴		地盤	
顏色	PPG UCT26065SC-3 3 Coats Bronze		工廠	