



工程指示 / 要求簡箋(E.I.)

工程指示編號：EI 6671/17. 修改版次：
 工程編號：J835. 工程名稱：TK066D 2nd 台
 工程項目：Glass Wall — 訂購電鍍雙掩門！
 收件人：羅小姐. 發件人：Eddie 日期：2017.1.10

要求提供 / 確認 事項：

- | | | |
|--|-------------------------------------|-------------------------------|
| <input type="checkbox"/> 初步鋁料 B.M. | <input type="checkbox"/> 加工拆圖，然後生產 | <input type="checkbox"/> 尺寸表 |
| <input type="checkbox"/> 正式鋁料 B.M. | <input type="checkbox"/> 技術上資料 / 指示 | <input type="checkbox"/> 報價 |
| <input type="checkbox"/> 配件 B.M. | <input type="checkbox"/> 樣辦或貨品說明書 | <input type="checkbox"/> 分判合約 |
| <input checked="" type="checkbox"/> 其他：_____ | | |

內容：

訂購 "Besam SW 300" 1 套
 一包裝包安裝

見附錄資料！

請在 _____ 前完成上列要求。

附有關圖紙 / 文件：

1+

以上項目為：

原合約工程包

原合約工程加 / 減賬

新工程報價

原因：-

分發東莞各部門：

- () 生產技術總監 連附件 () 技術部 連附件 () 生產部 連附件 () 機械設計部 連附件
 () 採購部 連附件 () 生產統籌部 連附件
 () 質檢部 連附件 () 會計部 連附件 () 報關組 連附件 () 其他 _____ 連附件

分發香港各部門：

- () 行政部 連附件 () 會計部 連附件 () 統籌部 連附件 () 工程部地盤科文 連附件
 () 採購部 連附件 () QS 部 連附件 () 維修部 連附件 () 其他 _____ 連附件

傳遞編號：

HK

發件人簽署：

(FTP)

項目經理簽署：

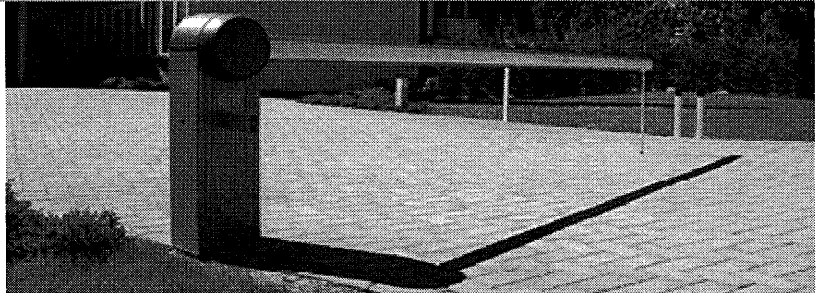
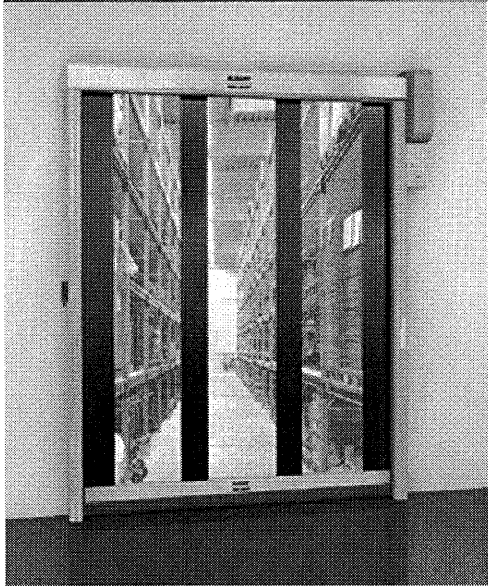

MIDI Aluminium Fabricator Ltd.

TKO 66D2 Podium

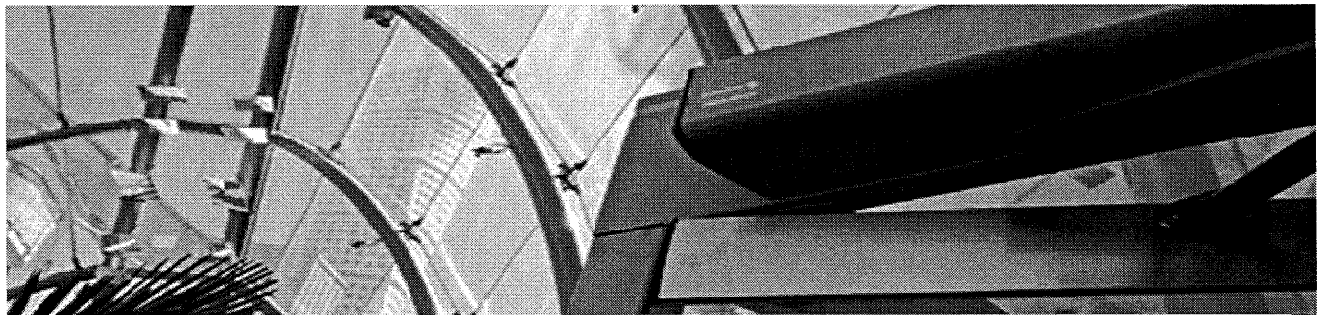

Quotation

ASSA ABLOY Entrance Systems

ASSA ABLOY

The global leader in
door opening solutions

Mr. York Law

Units 6-8, Sunray Industrial Center,
1/F, 610 Cha Kwo Ling Rd.,
Kowloon

Quotation

Dear Sir,

Enclosed is our proposal of the automatic door systems for TKO 66D2 Podium

Assa Abloy Entrance Systems is the world's most complete supplier of entrance automation solutions. With a holistic approach to the flow of people, goods and vehicles, we create solutions with the best possible balance of cost, quality and lifetime performance.

Today, we have gathered a strong portfolio of global brands under a single roof, preserving the wealth of expertise of each. Besam, Crawford, Megadoor and Albany are brands that are market leaders in their fields since decades and have a strong history of proven solutions and extraordinary service know-how.

Our solutions form a total offering for the front, back and interior of buildings. Our combined approach means we understand the full range of challenges you face and allow us to provide the best solution for your total entrance needs.

We hope that you find our proposal acceptable and looking forward to your favorable response soon.

Yours faithfully,



Jonathan
Salesman
M: (852) 9860 9867
Jonathan.fok@assaabloy.com

To supply & install Only "Besam" automatic double swing door system:-

DESCRIPTION	Qty.	Rate	Amount
<u>A1. For "Besam" automatic double swing door operator system:-</u>		HK\$	HK\$
To supply & install only "Besam", Heavy duty type, electro-mechanical automatic swing door system for door panel width not exceeding 1.4m and door panel weight not exceeding Inertia J for PUSH = 140 kgm ² or PULL = 80 kgm ² type, standard supply include the following:- - "Besam" SW300-2 operator (2 no.) - "Besam" std. Control Unit CU-300 (1 no.) - "Besam" operator cover (2 no.) - "Besam" PUSH arm system (2 no.) - "Besam" radar sensor (2 no.) - "Besam" 3 position switch (1 no.) - "Besam" door leaf mounted type safety sensor, kit2 with 2 nos sensors per each set (L=700mm) (4 no.) - "Besam" EXB extension unit for special application as Exit, inner impulse, outer impulse, key impulse & connection to other safety device. (1 no.) **No modification to the existing door leaf is required. **	1 set	\$53,800.00	\$53,800.00
<u>A2. Accessories items, please include if required:</u>			
1. "Besam" shaft extension, 70mm	0 no.	\$450.00	\$0.00
2. Electro-Magnetic Lockset for double door with break glass	0 no.	\$4,800.00	\$0.00
3. "Besam" PULL arm unit for in swing entrance, Cost to be in additional for Standard PUSH arm unit	0 no.	\$1,800.00	\$0.00
4. F.S. interface	0 no.	\$1,380.00	\$0.00
5. Other accessory are available upon request, please consult.			
Total amount in Hong Kong dollar for item A: -			\$53,800.00
Less special 5% discount for item A: -			(\$2,690.00)
Net Amount for item A: -			\$51,110.00

Exclude:-

1. Night shift installation.
2. Power supply, 230vac 13 amp.
3. All G. I. Conduits and the length of wiring over 3m.
4. All builder's and painting works.
5. All glass and door panel.
6. All Calculation.
7. F.S signal.
8. To Supply and install Scissor Platform, High Ladder and metal Scaffold.
9. Make good.
10. Items not selected, or not mentioned.

Con't to page

4

ASSA ABLOY Entrance Systems Hong Kong Ltd

Quote Number: Q-F-5467-b

Date: 8th July 2016

Quote valid until: 8th Aug 2016

Page 4 of 5

Payment:- 50% deposit, final payment should be released after completion of work and to be made within 30 days from present of invoice.

Delivery:- Ex-stock or 4~8 weeks from warehouse with 1 week with Sea freight delivery from official order confirmation.

Validity :- 1 month from the dated of this quotation, and price will be increased after that day due to variation of B/Q and /or change of terms/conditions of this quotation.

Quality Assurance:- All "Besam" products are **ISO9001** Quality Assurance on Design & Manufacture of Automatic door System.

Guarantee:- All "Besam" door operator and associated accessories, to be guarantee for 1 year against completion exclude door panels, glass panels which to be fabricated and assembled by other party. On the above item, subject to the following limitation:-

- 1) Wear & tear parts:-e.g. Floor guide, plastic tracks, wheels
- 2) Unauthorized repairs, misuse, Vandalism.
- 3) Damage from external corrosive & abrasive substances.
- 4) Act of God.

12 calendar months on parts & labour due to manufacturer's defects during office hours only.

Preventive Maintenance –

Preventive Maintenance contract is available separately. Please contact Ms Maisie Lai (Tel: 2260 7214) for a service programme catered to your requirement. (This is not included in the Warranty)

***** THE PRODUCT (AS DEFINED) SHALL REMAIN THE PROPERTY OF THIS COMPANY UNTIL & UNLESS ALL OUTSTANDING AMOUNTS OWNED BY THIS COMPANY HAVE BEEN SETTLED IN FULL BY YOUR COMPANY.*****

Thank you for the opportunity for quoting on your requirements. We look forward to receive your order.

Yours faithfully,



Jonathan Fok
Salesman
Tel: (852) 9860 9867

We accept & confirm this quotation,

Signature & Company's Stamp / Date

ASSA ABLOY Entrance Systems
Hong Kong Limited
Unit 1901, 19/F, Tower 3
China Hong Kong City
33 Canton Road, Tsim Sha Tsui, Kowloon
Tel : +852 2786 4711
Fax: +852 2745 2003

E-mail: info.aaeshk@assaabloy.com
www.assaabloyentrance.com

J

ASSA ABLOY Entrance Systems

One partner for all your automatic entrances

ASSA ABLOY Entrance Systems comprise world-leading products, maintenance programs and modernization services, ensuring total solutions for efficient flow of people, goods and vehicles. With comprehensive entrance solutions for the front, back and interior of your building, we put every automatic door equipment or service you need under one roof.

The perfect match for your building

ASSA ABLOY Entrance Systems' extensive product range, expert application knowledge and maintenance programs provide optimal entrance solutions for all needs and any demands in manufacturing, distribution & logistics, retail, healthcare, transportation, hospitality, private services, public services, mining and air & sea, and more.

Sustainable Solutions

We design, manufacture and service automatic entrance solutions that help you reach your sustainability goals for energy savings and minimal environmental impact.

Leading product brands backed by dedicated specialists

With our three specialized business areas; Pedestrian Door Solutions, Industrial Door & Docking Solutions and High-Performance Door Solutions, we offer market-leading product brands and a global service organization. With more than a century of aggregated engineering experience and application expertise ASSA ABLOY Entrance Systems is your ideal business partner to provide, maintain and modernize all of your automatic entrances.



Pedestrian Door Solutions

- * swing doors
- * sliding doors
- * revolving doors

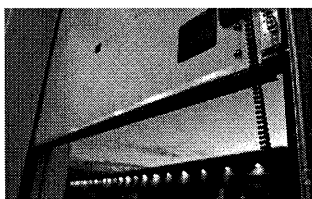

Industrial Door and Docking Solutions

- * industrial doors
- * complete docking systems
- * hangar doors



High-Performance Door Solutions

- * high speed roll doors
- * doors for special applications such as clean rooms, machine protection and food processing

ASSA ABLOY Entrance Systems
Hong Kong Limited
Unit 1901, 19/F, Tower 3
China Hong Kong City
33 Canton Road, Tsim Sha Tsui,
Kowloon
Tel : +852 2786 4711
Fax: +852 2745 2003

E-mail: info.aeshk@assaabloy.com
www.assaabloyentrance.com

Item 51

Besam SW300

- Swing Door Operator

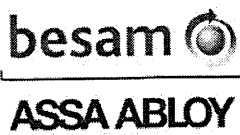

The Besam SW300 swing door operator is the perfect choice where reliable performance and superior safety together with an appealing slim look is of extra importance.

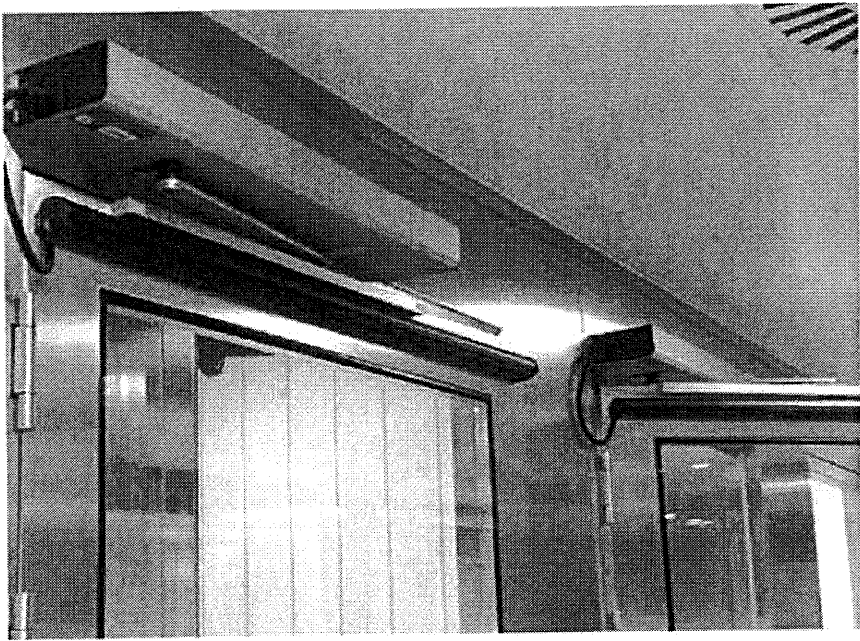

Standard equipment

- Singel operator, surface mounted
- Dimensions - 70 mm cover height and min. length 840 mm
- Double operator, surface mounted
- Dimensions - 70 mm cover height and min. length 1676 mm

Accessories and Options

- Programme selectors
- Sync cable for double doors (synchronization of 2 operators)
- Battery backup unit
- Coordination unit
- Impulse and presence detection sensors
- Fire kit
- Arm systems PUSH and PULL

Energy-efficiency

Besam automated door systems are sustainable by nature and automatically convenient as they ensure opening only when needed to pass, eliminating unnecessary air infiltration and keeping climate zones separate. The innovative electronics in the Besam SW300 ensure minimal energy consumption for optimal door performance.



Safety

The Besam SW300 is safe to use for all, despite age and physical ability. In case of an obstruction by a person or object, the obstruction control ensures stop on stall and reverse operation. Furthermore, the Besam SW300 swing door operator is fully compliant with European standards and fire approved, making it ideal for creating and maintaining security, smoke and fire zones.

Convenience

An entrance equipped with a Besam SW300 operator is always accessible due to battery back-up. The Besam SW300 also monitors the battery for power and function, and gives an electronic indication if it is not working properly and needs to be replaced.

The operator is truly reliable during all weather conditions as it is not affected by stack pressure and wind load when opening and/or closing. Also, for your convenience, safety and quick exit, the Besam SW300 can easily be manually opened, despite extended closing torque, due to sensor detection ensuring lowest manual opening force.

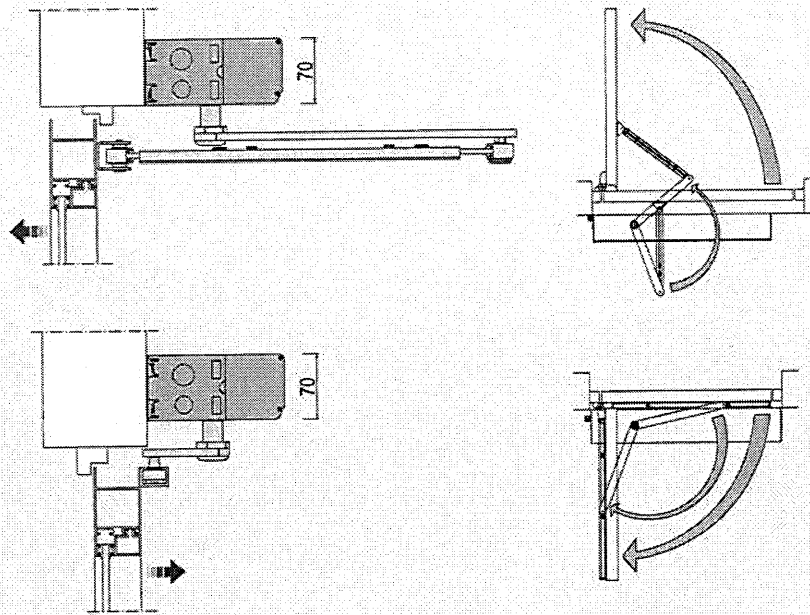

Security

The Besam SW300's intelligent locking features are designed for your peace of mind. For example, double doors are precisely controlled to prevent jamming and increase security. The Besam SW300 operator can also sense when the door has not closed completely and will prompt the door to open again and close fully, even under heavy wind load and stack pressure.

Aesthetics

The 70 mm slim Besam SW300 swing door requires a minimum of space while providing maximum performance. Furthermore, the door system operates impressively silent despite its amazing capability to handle heavy doors up to 250kg. The Besam SW300 can be retrofitted with existing doors and thereby keeping the overall door system design and environment aesthetically intact.

Technical specifications

Power supply:
100-240 VAC +10/-15%, 50/60 Hz,
mains fuse max 10A (building installation)

Power consumption: Max. 300 W

Auxiliary voltage: 24 V DC, max. 700 mA

Ambient temperature: -20 °C to +45 °C

Recommended max. door weight
and door width:

$$\text{Inertia } J = \frac{\text{Door Weight} \times (\text{door width})^2}{3}$$

PUSH = 140 kgm²

PULL = 80 kgm²

The SW300 complies with:

- EN 1154 (controlled door closing)
- EN 1158 (coordination unit for rebated doors)
- DIN 18263-4
- EN 1634-1
- EN 16005
- EN ISO 13849-1/-2
- EN 60335-1
- EN 60335-2-103
- EN 61000-6-2
- EN 61000-6-3



This equipment should be installed, regularly inspected, maintained and serviced by trained and authorized personnel. Preventive maintenance plans are highly recommended for a proper and safe operation. Talk to your ASSA ABLOY Entrance Systems representative to learn more about our service offering!

ASSA ABLOY Entrance Systems Hong Kong Limited

Suite 1901, 19/F, Tower 3
China Hong Kong City, 33 Canton Road
Tsim Sha Tsui, Kowloon
info.aeshk@assaabloy.com
Phone: +852 2786 4711
Fax: +852 2745 2003
www.assaabloyentrance.com

ASSA ABLOY

The global leader in
door opening solutions

