

工程指示 / 要求簡箋(E.I.)

工程指示編號：EI 6227/16. 修改版次：
 工程編號：J835. 工程名稱：將軍澳 GGD 平台
 工程項目：幕牆 - Glass Wall & Grille - 確認模身 x85378, x85379
 收件人：羅少祖 發件人：Eddie 日期：x85366, x85369
 x85376, x85377
 x85375
 2016.11.9

要求提供 / 確認 事項：

- | | | |
|---|-------------------------------------|-------------------------------|
| <input type="checkbox"/> 初步鋁料 B.M. | <input type="checkbox"/> 加工拆圖，然後生產 | <input type="checkbox"/> 尺寸表 |
| <input type="checkbox"/> 正式鋁料 B.M. | <input type="checkbox"/> 技術上資料 / 指示 | <input type="checkbox"/> 報價 |
| <input type="checkbox"/> 配件 B.M. | <input type="checkbox"/> 樣辦或貨品說明書 | <input type="checkbox"/> 分判合約 |
| <input checked="" type="checkbox"/> 其他：模身 | | |

內容：

現確認模身 x85378, x85379, x85366,
 x85369, x85376, x85377
 x85375 (共 7 個款模身)

請提供 500mm 鋁料辦理確認

請在 2016.11.12 前完成上列要求。

附有關圖紙 / 文件：

1+ JB

以上項目為：

- 原合約工程包 原合約工程加 / 減賬 新工程報價

原因：-

分發東莞各部門：

- () 生產技術總監 連附件 () 技術部 連附件 () 生產部 連附件 () 機械設計部 連附件
 () 採購部 連附件 () 生產統籌部 連附件
 () 質檢部 連附件 () 會計部 連附件 () 報關組 連附件 () 其他 連附件

分發香港各部門：

- () 行政部 連附件 () 會計部 連附件 () 統籌部 連附件 () 工程部地盤科文 連附件
 () 採購部 連附件 () QS 部 連附件 () 維修部 連附件 () 其他 連附件

傳遞編號：

HK 2514/16 (FTP)

發件人簽署：

項目經理簽署：

CUSTOMER	HONGKONG CO.	CUSTOMER APPROVAL		CUST PART NO.	X85378
				SECTION NO.	LH0088216

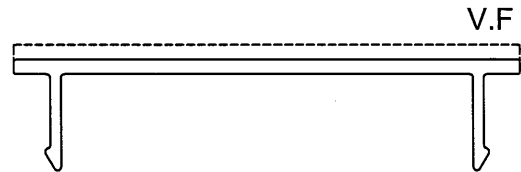
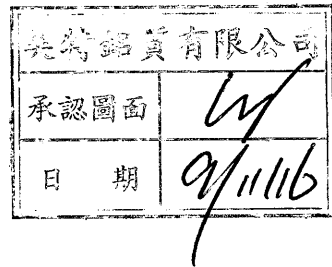
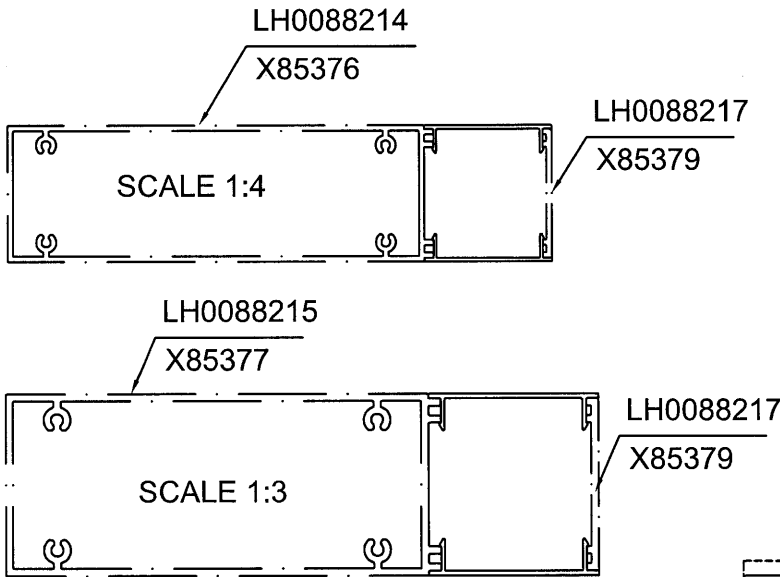
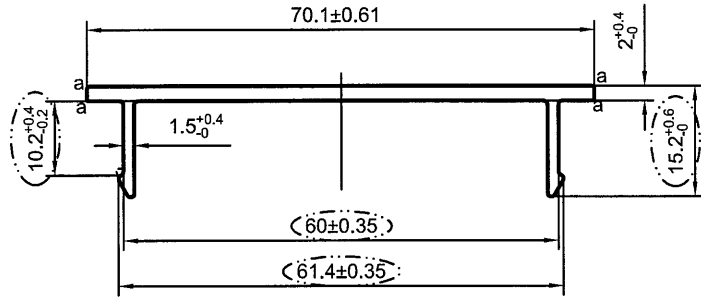

a=R0.3

*配合尺寸以实物配合效果为准!

SCALE 1:1

SIGNATURE GRADEING	HIGH SIGNATURE GRADEING	C.C.DIA(MM)	Ø 70.11						
AREA (SQ MM)	180.59 (199.13)	UNSPECIFIED THICKNESS		PERIMETER (MM)	195	STANDARD	GB 5237.1	SCALE	1:1
MASS (KG/M)	0.54	UNSPECIFIED CORNERS	R 0.5	SURFACE AREA	70.44	ALLOY	6063-T5	VERSION	B
COMPANY ISSUE		B	DRAWA	蔡晓巡	DATE	2016-10-27	APELLATION	-	PAGE OF
			STANDA-RDIZATION		DATE				
			TO SIGN	陈国提	DATE				
			AUDITING		DATE				
MARKER	MODIFY	FILE NO	SIGNATURE	DATE	APPROV				



CUSTOMER	HONGKONG CO.	CUSTOMER APPROVAL	CUST PART NO.	X85379
			SECTION NO.	LH0088217

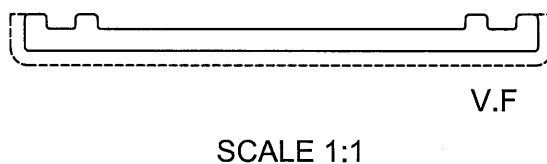
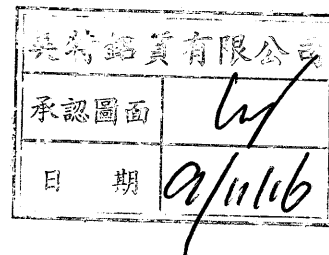
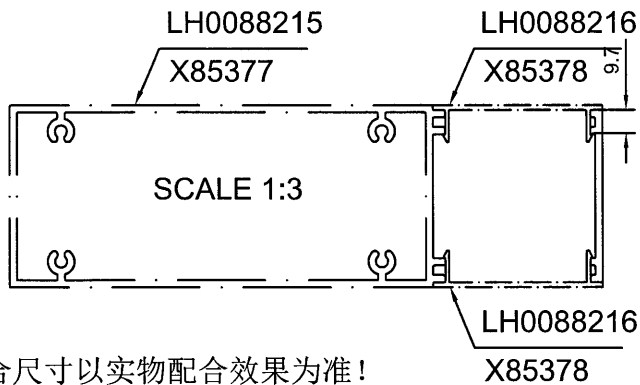
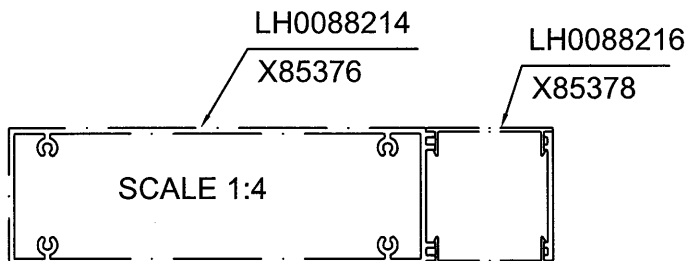
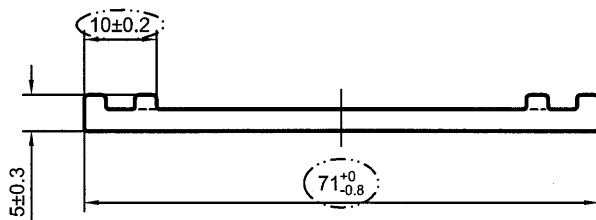

*配合尺寸以实物配合效果为准!

SIGNATURE GRADEING	HIGH SIGNATURE GRADEING	C.C.DIA(MM)	Ø 71.11						
AREA (SQ MM)	236.78 (250.02)	UNSPECIFIED THICKNESS	3 ^{+0.4} ₋₀	PERIMETER (MM)	160.57	STANDARD	GB 5237.1	SCALE	1:1
MASS (KG/M)	0.678	UNSPECIFIED CORNERS	R 0.5	SURFACE AREA	81.14	ALLOY	6063-T5	VERSION	B
COMPANY ISSUE		B	DRAWA	蔡晓巡	DATE	2016-10-27	APPELLATION	-	PAGE OF
			STANDA-RDIZATION		DATE				
			TO SIGN	陈国提	DATE				
			AUDITING		DATE				
MARKER	MODIFY	FILE NO	SIGNATURE	DATE	APPROV				



CUSTOMER	HONGKONG CO.	CUSTOMER APPROVAL	CUST PART NO.	X85366
			SECTION NO.	LH0088204

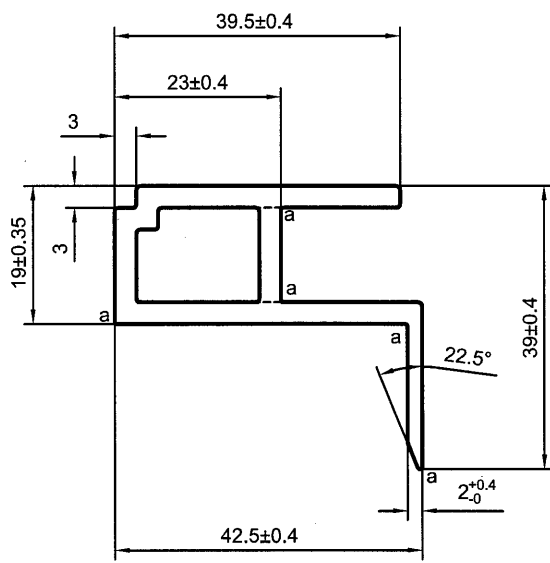

美特铝业有限公司	
承認圖面	<i>[Signature]</i>
日期	09/11/16

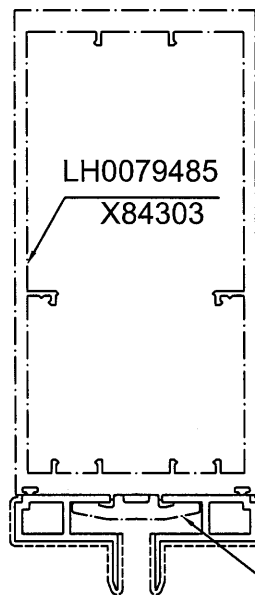
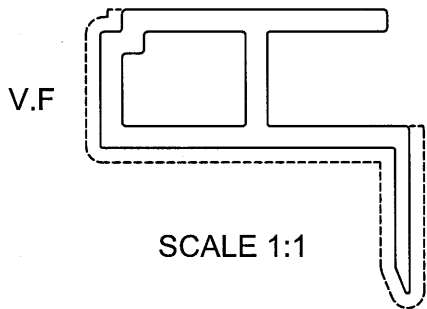

LH0088205
X85367

a=R0.3

*配合尺寸以实物配合效果为准!

SIGNATURE GRADEING	HIGH SIGNATURE GRADEING	C.C.DIA(MM)	Ø 55.37		SCALE 1:3				
AREA (SQ MM)	361.28 (383.55)	UNSPECIFIED THICKNESS	3 ^{+0.4} / ₋₀	PERIMETER (MM)	192.8	STANDARD	GB 5237.1	SCALE	1:1
MASS (KG/M)	1.039	UNSPECIFIED CORNERS	R 0.5	SURFACE AREA	105.99	ALLOY	6063-T6	VERSION	B
COMPANY ISSUE		B	DRAWA	蔡晓巡	DATE	2016-10-31	APELLATION	-	PAGE OF
			STANDA-RDIZATION		DATE				
			TO SIGN	陈国提	DATE				
			AUDITING		DATE				
MARKER	MODIFY	FILE NO	SIGNATURE	DATE	APPROV				



4

CUSTOMER	HONGKONG CO.	CUSTOMER APPROVAL	CUST PART NO.	X85369
			SECTION NO.	LH0088207

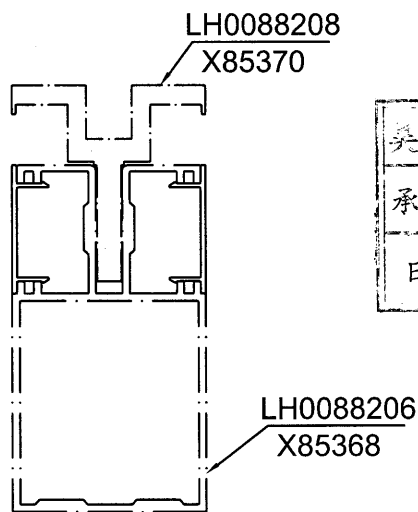
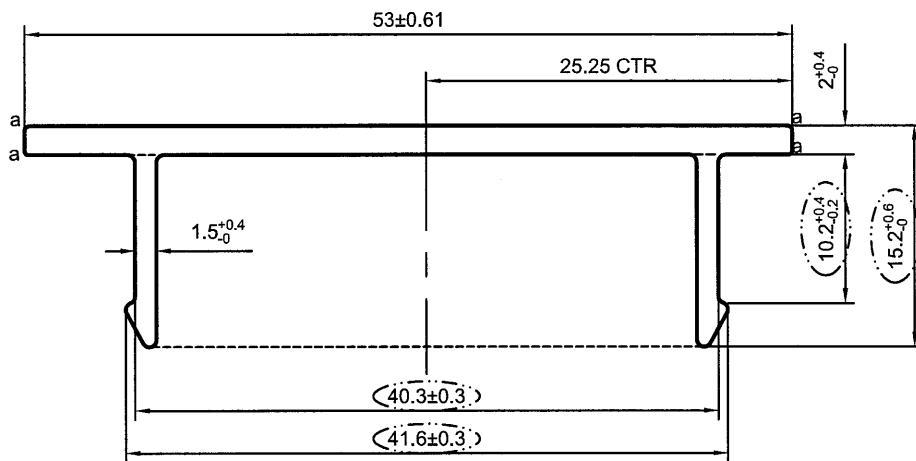

美特铝业有限公司
 承認圖面
 日期 9/11/16

SCALE 1:3

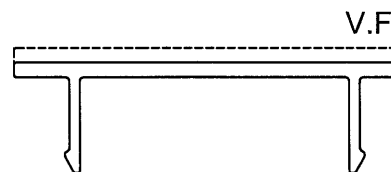

a=R0.3

*配合尺寸以实物配合效果为准!

SCALE 1:1

SIGNATURE GRADEING	HIGH SIGNATURE GRADEING	C.C.DIA(MM)	Ø 53.02						
AREA (SQ MM)	146.2 (161.32)	UNSPECIFIED THICKNESS	PERIMETER (MM)	160.67	STANDARD	GB 5237.1	SCALE	2:1	
MASS (KG/M)	0.437	UNSPECIFIED CORNERS	R 0.5	SURFACE AREA	53.34	ALLOY	6063-T5	VERSION	B
COMPANY ISSUE		B	DRAWA	蔡晓巡	DATE	2016-10-27	APELLATION	-	PAGE OF
			STANDA-RDIZATION		DATE				
			TO SIGN	陈国提	DATE				
			AUDITING		DATE				
MARKER	MODIFY	FILE NO	SIGNATURE	DATE	APPROV	DATE			

PANASIA ALUMINUM (CHINA) LIMITED

CUSTOMER	HONGKONG CO.	CUSTOMER APPROVAL	CUST PART NO.	X85376
			SECTION NO.	LH0088214

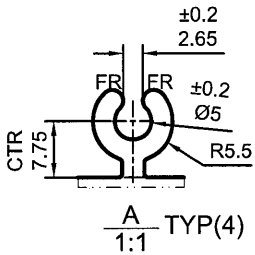
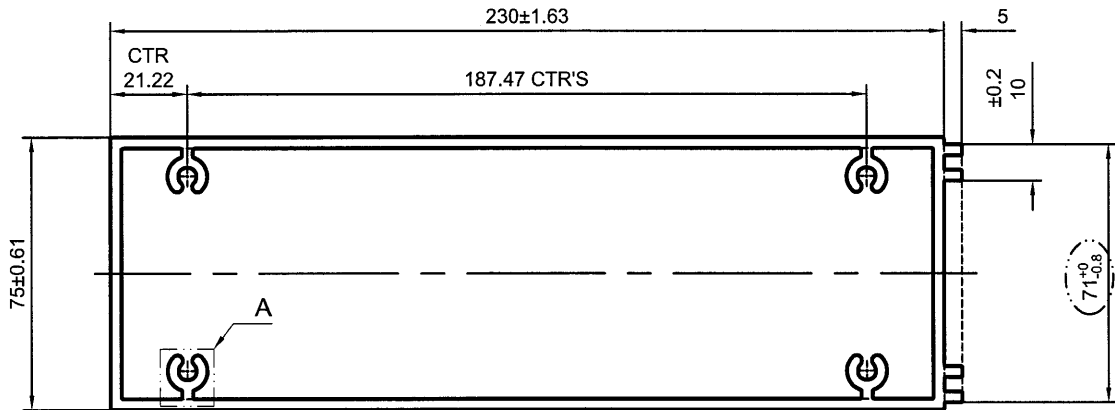

英荷鋁業有限公司	
承認圖面	<i>[Signature]</i>
日期	2016/10/26

V.F

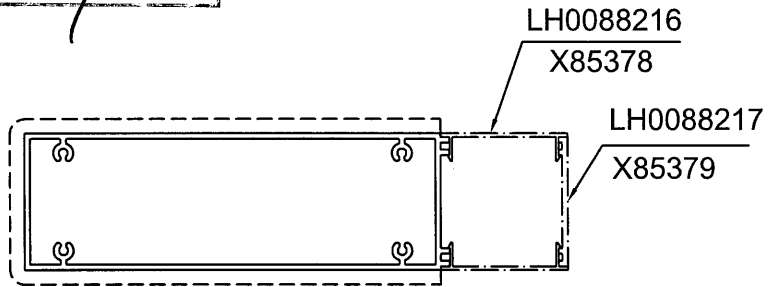

*配合尺寸以实物配合效果为准!

SCALE 1:4

SIGNATURE GRADEING	HIGH SIGNATURE GRADEING	C.C.DIA(MM)	Ø 245.84						
AREA (SQ MM)	2136.95 (2255.59)	UNSPECIFIED THICKNESS	3 ^{+0.4} ₋₀	PERIMETER (MM)	645.71	STANDARD	GB 5237.1	SCALE	1:2
MASS (KG/M)	6.113	UNSPECIFIED CORNERS	R 0.5	SURFACE AREA	535.14	ALLOY	6063-T6	VERSION	B
COMPANY ISSUE		B	DRAWA	蔡晓巡	DATE	2016-10-27	APELLATION	-	PAGE OF
			STANDA-RDIZATION		DATE				
			TO SIGN	陈国提	DATE				
			AUDITING		DATE				
MARKER	MODIFY	FILE NO	SIGNATURE	DATE	APPROV				



PANASIA ALUMINUM (CHINA) LIMITED

6

CUSTOMER	HONGKONG CO.	CUSTOMER APPROVAL	CUST PART NO.	X85377
			SECTION NO.	LH0088215

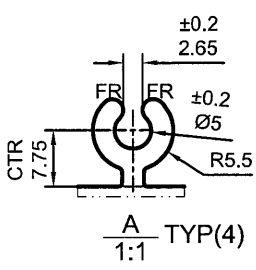
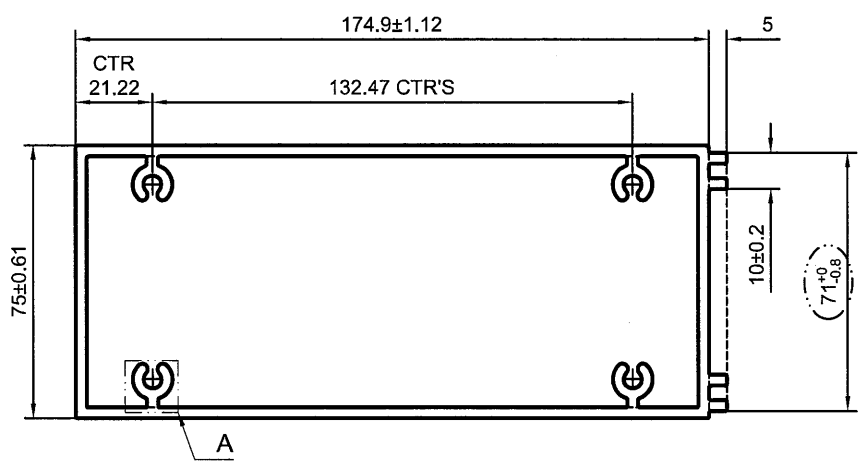

共新鋁質有限公司
承認圖面
日期 2016/11/16

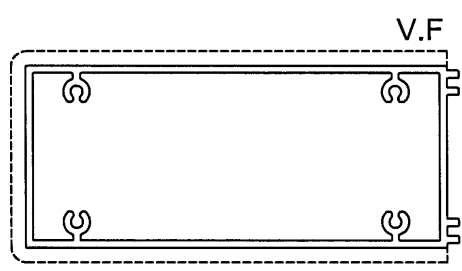
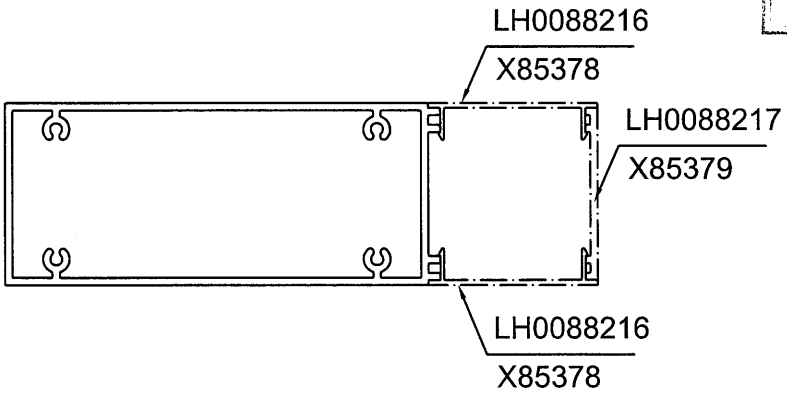

*配合尺寸以实物配合效果为准!

SCALE 1:3

SIGNATURE GRADEING	HIGH SIGNATURE GRADEING	C.C.DIA(MM)	Ø 193.86						
AREA (SQ MM)	1806.35 (1902.95)	UNSPECIFIED THICKNESS	3 ^{+0.4} ₋₀	PERIMETER (MM)	535.51	STANDARD	GB 5237.1	SCALE	1:2
MASS (KG/M)	5.157	UNSPECIFIED CORNERS	R 0.5	SURFACE AREA	424.94	ALLOY	6063-T6	VERSION	B
COMPANY ISSUE		B	DRAWA	蔡晓巡	DATE	2016-10-27	APELLATION	-	PAGE OF
			STANDA-RDIZATION		DATE				
			TO SIGN	陈国提	DATE				
			AUDITING		DATE				
MARKER	MODIFY	FILE NO	SIGNATURE	DATE	APPROV				

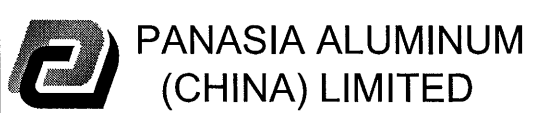

7

CUSTOMER	HONGKONG CO.	CUSTOMER APPROVAL	CUST PART NO.	X85375
			SECTION NO.	LH0088213

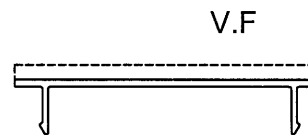
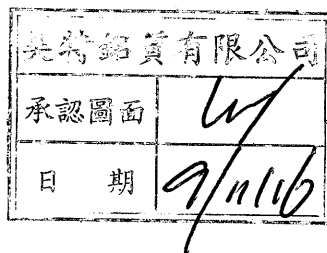
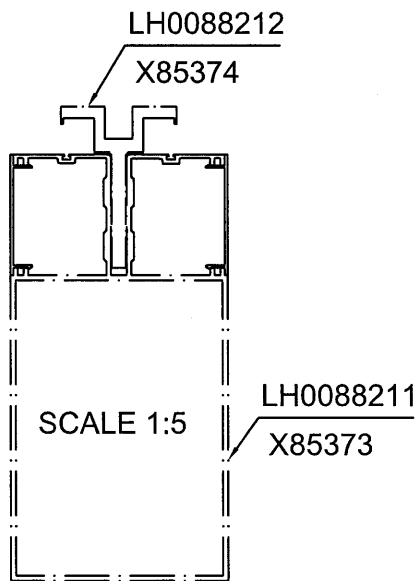
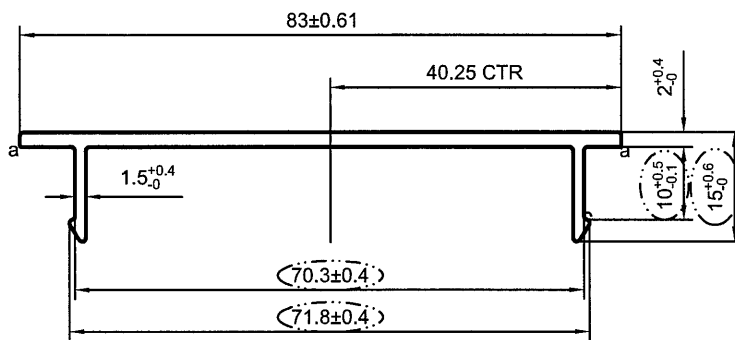

a=R0.3

*配合尺寸以实物配合效果为准!

SCALE 1:2

SIGNATURE GRADEING	HIGH SIGNATURE GRADEING	C.C.DIA(MM)	Ø 83.01						
AREA (SQ MM)	205.94 (226.98)	UNSPECIFIED THICKNESS	PERIMETER (MM)	220.04	STANDARD	GB 5237.1	SCALE	1:1	
MASS (KG/M)	0.615	UNSPECIFIED CORNERS	R 0.5	SURFACE AREA	83.46	ALLOY	6063-T5	VERSION	C
COMPANY ISSUE		B	DRAWA	蔡晓巡	DATE	2016-10-27	APPELLATION	-	PAGE OF
			STANDARDIZATION		DATE		 PANASIA ALUMINUM (CHINA) LIMITED		
			TO SIGN	陈国提	DATE				
			AUDITING		DATE				
MARKER	MODIFY	FILE NO	SIGNATURE	DATE	APPROV	DATE			