



工程指示 / 要求簡箋(E.I.)

工程指示編號：EI 5989/16 修改版次：
 工程編號：JB35 工程名稱：TKO 118平台
 工程項目：幕牆、玻璃牆、鋁棚格及鋁摺件 — 確認橫圖圖紙
 收件人：羅小姐 發件人：Eddie 日期：2016.10.4
 X85366-X85383, X85385-X85389, X85392-X85397

要求提供 / 確認 事項：

- | | | |
|---|-------------------------------------|-------------------------------|
| <input type="checkbox"/> 初步鋁料 B.M. | <input type="checkbox"/> 加工拆圖，然後生產 | <input type="checkbox"/> 尺寸表 |
| <input type="checkbox"/> 正式鋁料 B.M. | <input type="checkbox"/> 技術上資料 / 指示 | <input type="checkbox"/> 報價 |
| <input type="checkbox"/> 配件 B.M. | <input type="checkbox"/> 樣辦或貨品說明書 | <input type="checkbox"/> 分判合約 |
| <input checked="" type="checkbox"/> 其他： <u>橫圖圖紙</u> | | |

內容：

現確認橫圖圖紙 X85366-85383, X85385-X85389
及 X85392-X85397 (共29個)

請在 2016.10.11 前完成上列要求。

附有關圖紙 / 文件：

1+ 29張

以上項目為：

- 原合約工程包 原合約工程加 / 減賬 新工程報價

原因：-

分發東莞各部門：

- | | | | |
|--|---|---|--|
| <input type="checkbox"/> 生產技術總監 <input type="checkbox"/> 連附件 | <input type="checkbox"/> 技術部 <input type="checkbox"/> 連附件 | <input type="checkbox"/> 生產部 <input type="checkbox"/> 連附件 | <input type="checkbox"/> 機械設計部 <input type="checkbox"/> 連附件 |
| <input type="checkbox"/> 採購部 <input type="checkbox"/> 連附件 | <input checked="" type="checkbox"/> 生產統籌部 <input checked="" type="checkbox"/> 連附件 | | |
| <input checked="" type="checkbox"/> 質檢部 <input type="checkbox"/> 連附件 | <input type="checkbox"/> 會計部 <input type="checkbox"/> 連附件 | <input type="checkbox"/> 報關組 <input type="checkbox"/> 連附件 | <input checked="" type="checkbox"/> 其他 <u>倉庫</u> <input checked="" type="checkbox"/> 連附件 |

分發香港各部門：

- | | | | |
|---|--|---|--|
| <input type="checkbox"/> 行政部 <input type="checkbox"/> 連附件 | <input type="checkbox"/> 會計部 <input type="checkbox"/> 連附件 | <input type="checkbox"/> 統籌部 <input type="checkbox"/> 連附件 | <input type="checkbox"/> 工程部地盤科文 <input type="checkbox"/> 連附件 |
| <input type="checkbox"/> 採購部 <input type="checkbox"/> 連附件 | <input type="checkbox"/> QS 部 <input type="checkbox"/> 連附件 | <input type="checkbox"/> 維修部 <input type="checkbox"/> 連附件 | <input type="checkbox"/> 其他 _____ <input type="checkbox"/> 連附件 |

傳遞編號：

HK 2110/16 (FTP)

發件人簽署：

[Signature] 2016.10.4

項目經理簽署：

CUSTOMER		CUSTOMER APPROVAL		CUST PART NO.	X85366
				SECTION NO.	

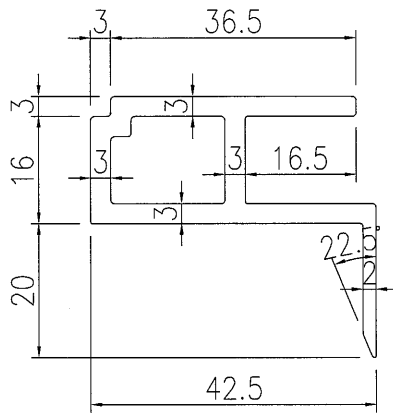

美特鋁質有限公司	
承認圖面	<i>[Signature]</i>
日期	2/10/16

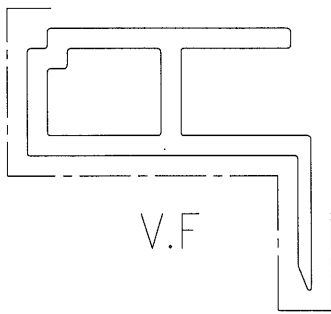

*所有壁厚只接受正公差

X843030

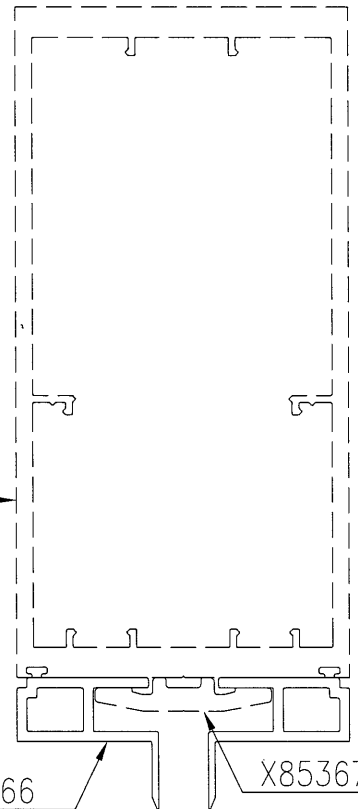

SIGNATURE GRADEING	HIGH SIGNATURE GRADEING	C.C.DIA(MM)							
AREA (SQ MM)	361.28	UNSPECIFIED THICKNESS	-	PERIMETER (MM)	251.51	STANDARD		SCALE	1:1
MASS (KG/M)	0.979	UNSPECIFIED CORNERS	-	SURFACE AREA	105.2	ALLOY	6063-T6	VERSION	
COMPANY ISSUE			DRAWA	XIA	DATE	16.09.30	APPELLATION	-	PAGE OF
			STANDA-		DATE				
			RDIZATI-		DATE				
			ON		DATE				
			AUDITING		DATE				
MARKER	MODIFY FILE NO	SIGNATURE	DATE	APPROV		DATE			

CUSTOMER	CUSTOMER APPROVAL	CUST PART NO.	X85367
		SECTION NO.	

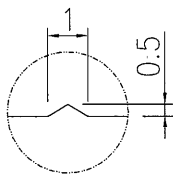
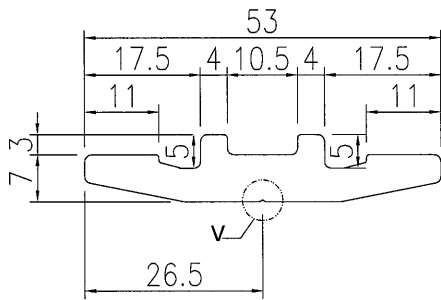

DETAIL "V" 6:1

X843030

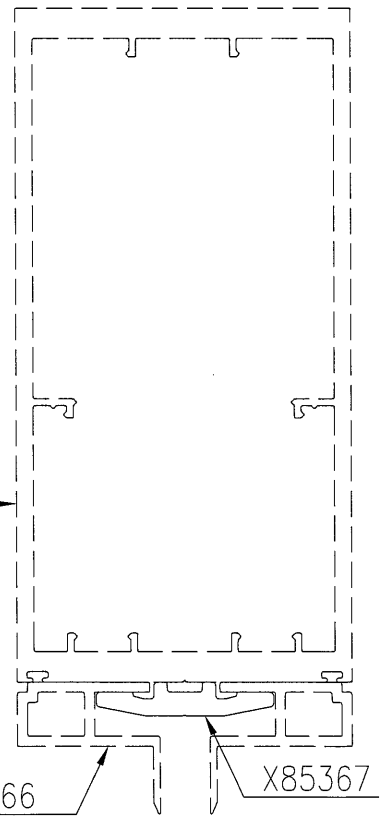

美特鋁質有限公司	
承認圖面	<i>[Signature]</i>
日期	2/10/16

*所有壁厚只接受正公差

SIGNATURE GRADEING	HIGH SIGNATURE GRADEING	C.C. DIA(MM)							
AREA (SQ MM)	328.93	UNSPECIFIED THICKNESS	-	PERIMETER (MM)	128.49	STANDARD		SCALE	1:1
MASS (KG/M)	0.891	UNSPECIFIED CORNERS	-	SURFACE AREA	-	ALLOY	6063-T6	VERSION	
COMPANY ISSUE			DRAWN	XIA	DATE	16.09.30	APPELLATION	-	PAGE OF
			STANDARDIZATION		DATE				
			TO SIGN		DATE				
			AUDITING		DATE				
MARKER	MODIFY FILE NO	SIGNATURE	DATE	APPROV		DATE			

CUSTOMER	CUSTOMER APPROVAL	CUST PART NO.	X85368
		SECTION NO.	

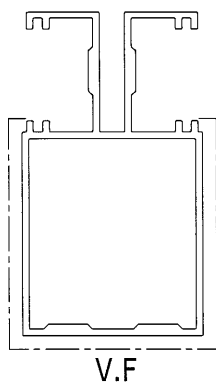
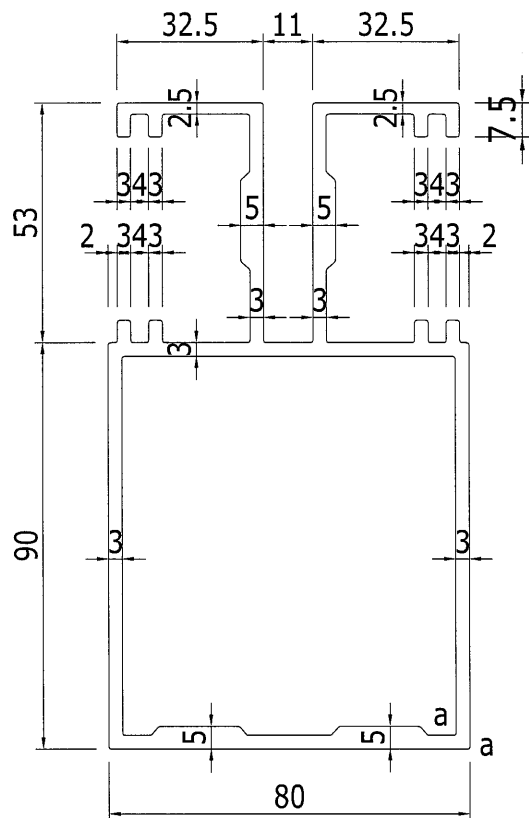

美特鋁質有限公司	
承認圖面	<i>[Signature]</i>
日期	3/10/16

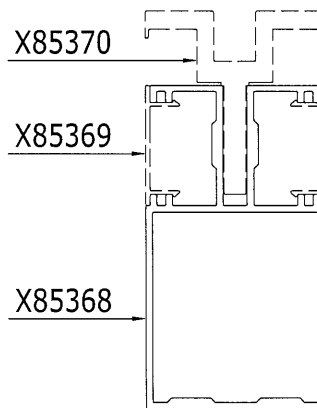

SIGNATURE GRADEING	HIGH SIGNATURE GRADEING	C.C.DIA(MM)	a=R0.5		*所有壁厚只接受正公差				
AREA (SQ MM)	1727.34	UNSPECIFIED THICKNESS	-	PERIMETER (MM)	1062.55	STANDARD		SCALE	1:1
MASS (KG/M)	4.68	UNSPECIFIED CORNERS	-	SURFACE AREA	260.13	ALLOY	6063-T6	VERSION	
COMPANY ISSUE			DRAWN	XIA	DATE	16.09.30	APELLATION	-	PAGE OF
			STANDARDIZATION		DATE				
			TO SIGN		DATE				
			AUDITING		DATE				
MARKER	MODIFY FILE NO	SIGNATURE	DATE	APPROV		DATE			

CUSTOMER	CUSTOMER APPROVAL	CUST PART NO.	X85369
		SECTION NO.	

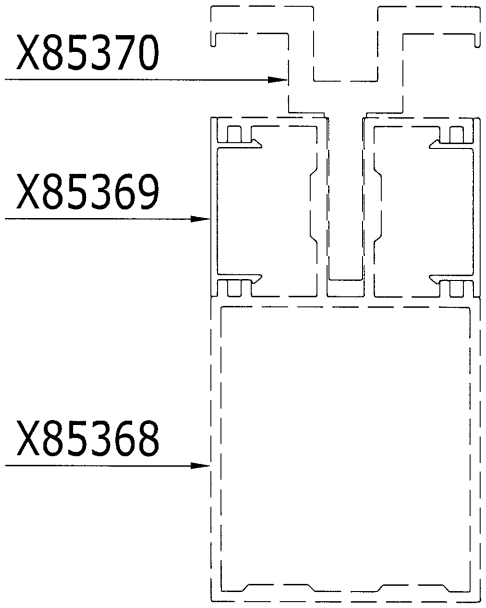
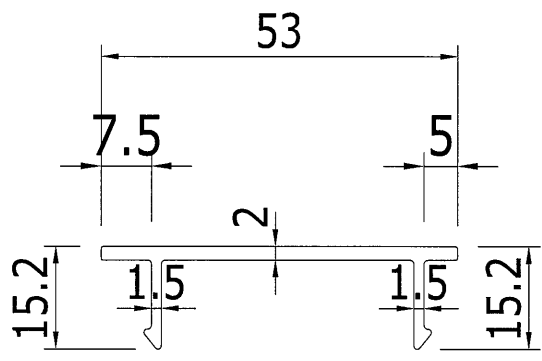

美特鋁質有限公司	
承認圖面	<i>[Signature]</i>
日期	3/10/16

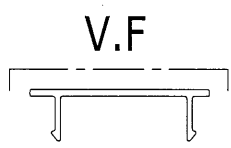

*所有壁厚只接受正公差

SIGNATURE GRADEING	HIGH SIGNATURE GRADEING	C.C.DIA(MM)							
AREA (SQ MM)	147.89	UNSPECIFIED THICKNESS	-	PERIMETER (MM)	162.03	STANDARD		SCALE	1:1
MASS (KG/M)	0.4	UNSPECIFIED CORNERS	-	SURFACE AREA	54.04	ALLOY	6063-T5	VERSION	
COMPANY ISSUE		DRAWN	XIA	DATE	16.09.30	APPELLATION	-	PAGE OF	
		STANDARDIZATION		DATE		美特鋁質有限公司 MIDI Aluminium Fabricator Ltd.			
		TO SIGN		DATE					
		AUDITING		DATE					
MARKER	MODIFY FILE NO	SIGNATURE	DATE	APPROV	DATE				

5

CUSTOMER		CUSTOMER APPROVAL		CUST PART NO.	X85370
				SECTION NO.	

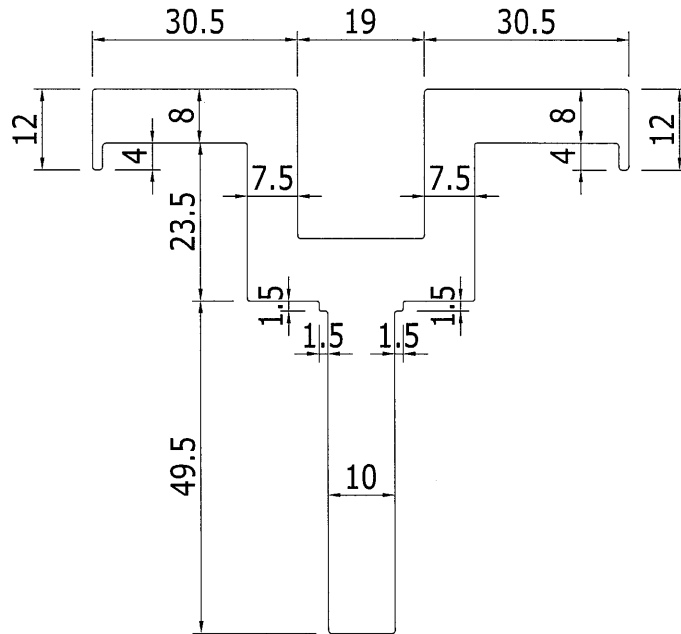

美特鋁質有限公司	
承認圖面	<i>[Signature]</i>
日期	2/10/16

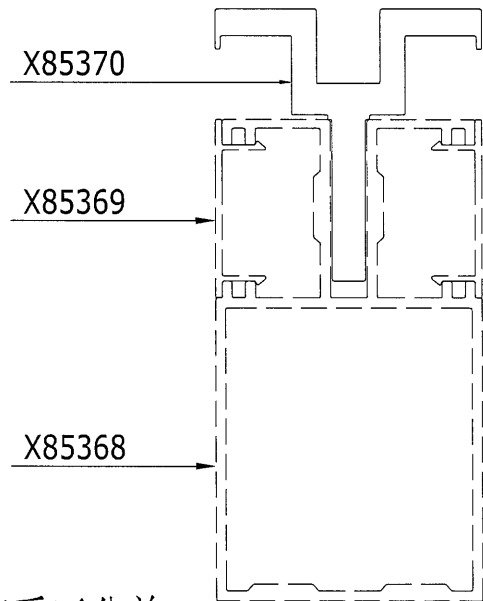

*所有壁厚只接受正公差

SIGNATURE GRADEING	HIGH SIGNATURE GRADEING	C.C.DIA(MM)		*所有壁厚只接受正公差				
AREA (SQ MM)	1527.85	UNSPECIFIED THICKNESS	-	PERIMETER (MM)	378.11	STANDARD	SCALE	1:1
MASS (KG/M)	4.14	UNSPECIFIED CORNERS	-	SURFACE AREA	-	ALLOY	6061-T6	VERSION
COMPANY ISSUE		DRAWN	XIA	DATE	16.09.30	APPELLATION	-	PAGE OF
		STANDARDIZATION		DATE				
		TO SIGN		DATE				
		AUDITING		DATE				
MARKER	MODIFY FILE NO	SIGNATURE	DATE	APPROV	DATE			

CUSTOMER		CUSTOMER APPROVAL		CUST PART NO.	X85371
				SECTION NO.	

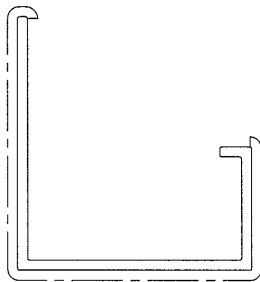
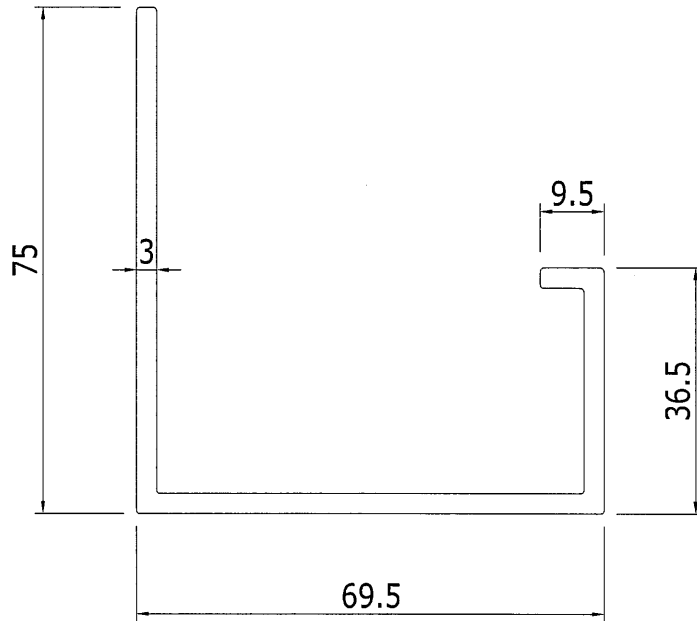

V.F

美特鋁質有限公司	
承認圖面	<i>[Signature]</i>
日期	2/10/16

*所有壁厚只接受正公差

SIGNATURE GRADEING	HIGH SIGNATURE GRADEING	C.C.DIA(MM)							
AREA (SQ MM)	544.29	UNSPECIFIED THICKNESS	-	PERIMETER (MM)	366.85	STANDARD		SCALE	1:1
MASS (KG/M)	1.475	UNSPECIFIED CORNERS	-	SURFACE AREA	183.92	ALLOY	6063-T6	VERSION	
COMPANY ISSUE			DRAWN	XIA	DATE	16.09.30	APPELLATION	-	PAGE OF
			STANDARDIZATION		DATE		美特鋁質有限公司 MIDI Aluminium Fabricator Ltd.		
			TO SIGN		DATE				
			AUDITING		DATE				
MARKER	MODIFY FILE NO	SIGNATURE	DATE	APPROV		DATE			

CUSTOMER	CUSTOMER APPROVAL	CUST PART NO.	X85372
		SECTION NO.	

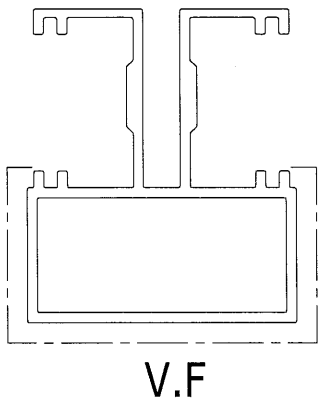
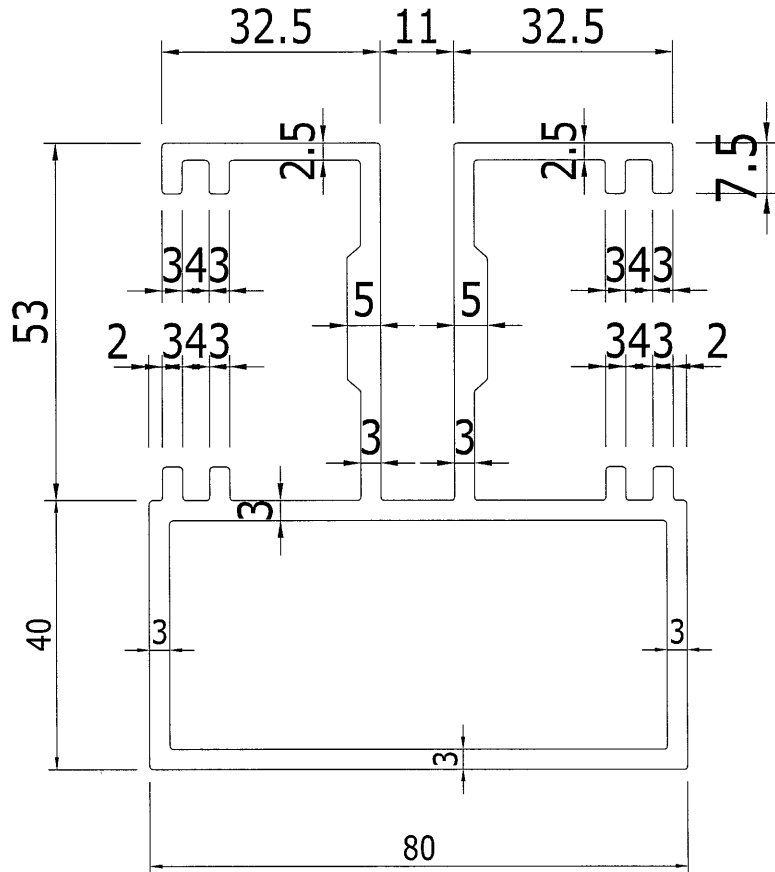

美特鋁質有限公司
承認圖面
日期 3/10/16

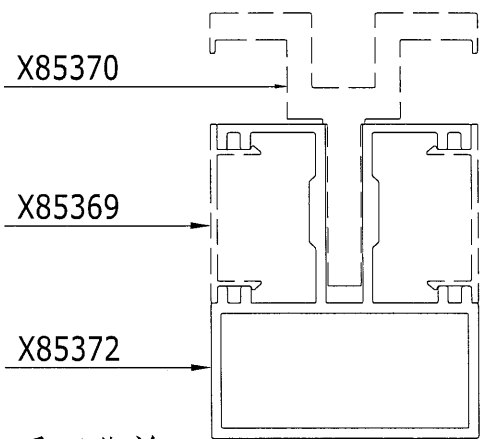

*所有壁厚只接受正公差

SIGNATURE GRADEING	HIGH SIGNATURE GRADEING	C.C.DIA(MM)							
AREA (SQ MM)	1348.42	UNSPECIFIED THICKNESS	-	PERIMETER (MM)	859.12	STANDARD		SCALE	1:1
MASS (KG/M)	3.65	UNSPECIFIED CORNERS	-	SURFACE AREA	160.13	ALLOY	6063-T6	VERSION	
COMPANY ISSUE			DRAWN	XIA	DATE	16.09.30	APPELLATION	-	PAGE OF
			STANDARDIZATION		DATE				
			TO SIGN		DATE				
			AUDITING		DATE				
MARKER	MODIFY FILE NO	SIGNATURE	DATE	APPROV		DATE			

CUSTOMER	CUSTOMER APPROVAL	CUST PART NO.	X85373
		SECTION NO.	

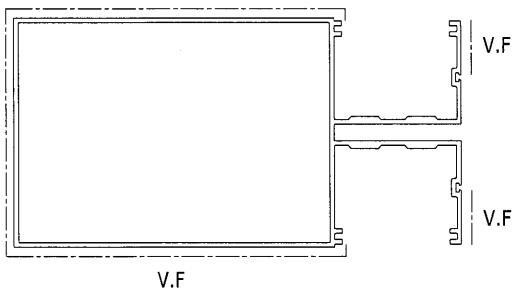
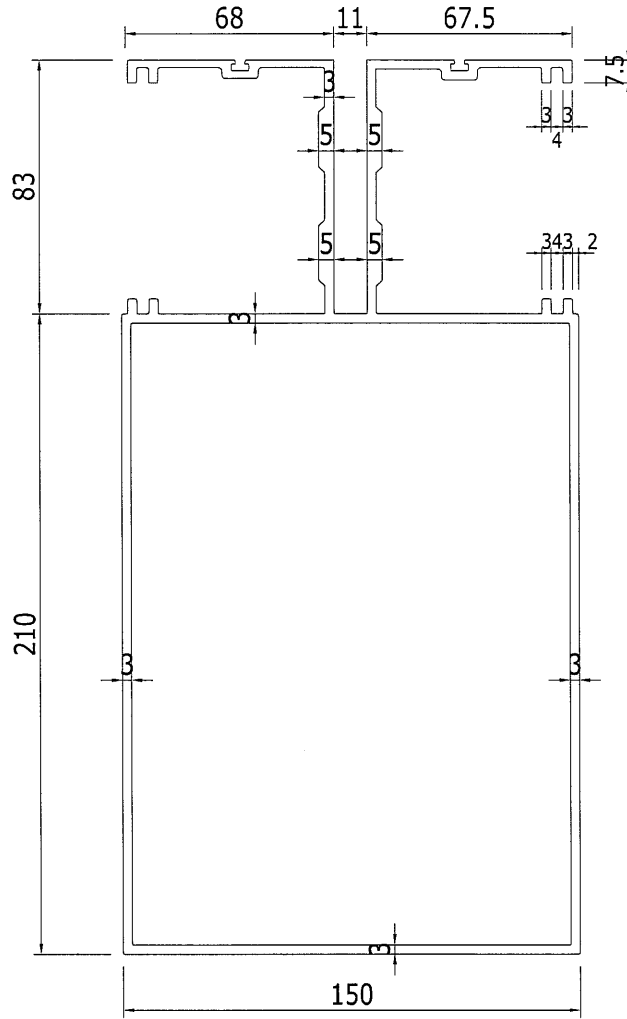

美特鋁質有限公司	
承認圖面	<i>[Signature]</i>
日期	3/10/16

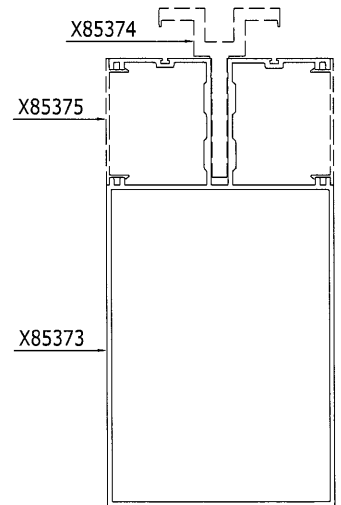

*所有壁厚只接受正公差

SIGNATURE GRADEING	HIGH SIGNATURE GRADEING	C.C.DIA(MM)		*所有壁厚只接受正公差						
AREA (SQ MM)	3179.11	UNSPECIFIED THICKNESS	-	PERIMETER (MM)	2051.99	STANDARD		SCALE	1:1	
MASS (KG/M)	8.615	UNSPECIFIED CORNERS	-	SURFACE AREA	618.58	ALLOY	6063-T6	VERSION		
COMPANY ISSUE				DRAWN	XIA	DATE	16.09.30	APPELLATION	-	PAGE OF
				STANDARDIZATION		DATE				
				TO SIGN		DATE				
				AUDITING		DATE				
MARKER	MODIFY FILE NO	SIGNATURE	DATE	APPROV		DATE				

CUSTOMER		CUSTOMER APPROVAL		CUST PART NO.	X85374
				SECTION NO.	

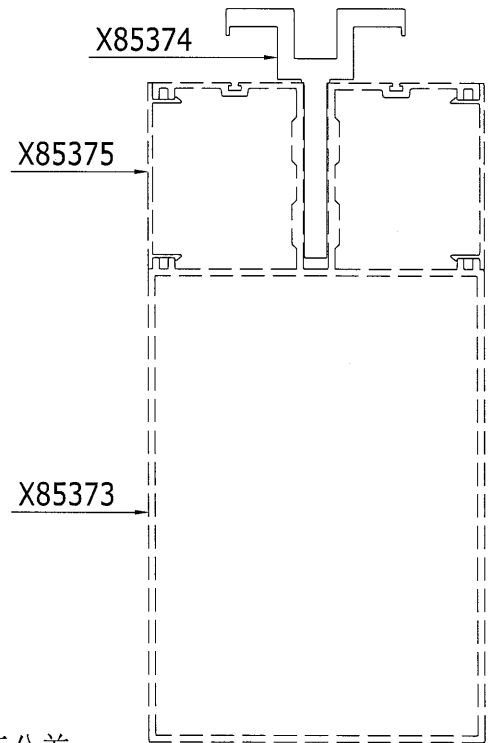
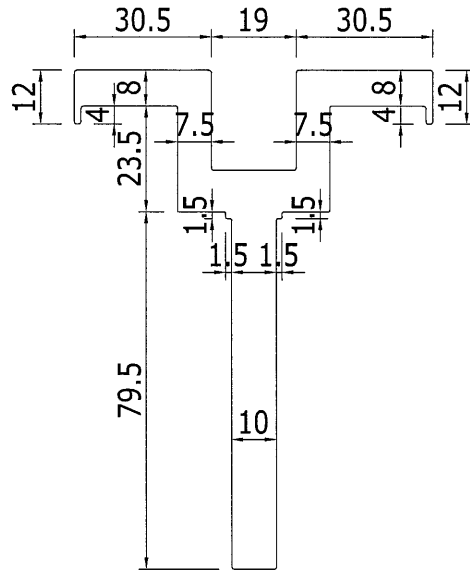

美特鋁質有限公司	
承認圖面	<i>CV</i>
日期	3/10/16

*所有壁厚只接受正公差

SIGNATURE GRADEING	HIGH SIGNATURE GRADEING	C.C.DIA(MM)							
AREA (SQ MM)	1827.84	UNSPECIFIED THICKNESS	-	PERIMETER (MM)	438.10	STANDARD		SCALE	1:1
MASS (KG/M)	4.953	UNSPECIFIED CORNERS	-	SURFACE AREA	-	ALLOY	6061-T6	VERSION	
COMPANY ISSUE			DRAWN	XIA	DATE	16.09.30	APPELLATION	-	PAGE OF
			STANDARDIZATION		DATE				
			TO SIGN		DATE				
			AUDITING		DATE				
MARKER	MODIFY FILE NO	SIGNATURE	DATE	APPROV	DATE				

CUSTOMER		CUSTOMER APPROVAL		CUST PART NO.	X85375
				SECTION NO.	

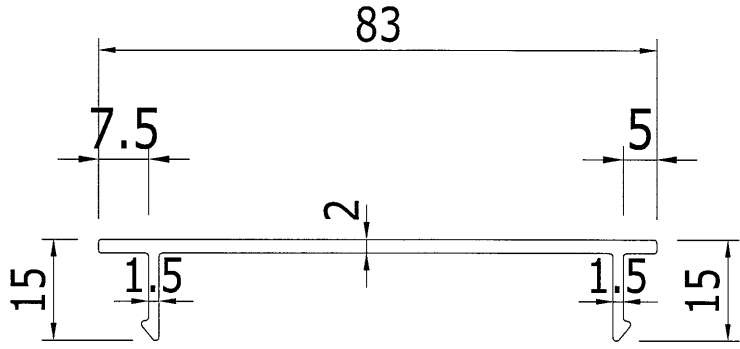

美特鋁質有限公司	
承認圖面	<i>[Signature]</i>
日期	2/10/16

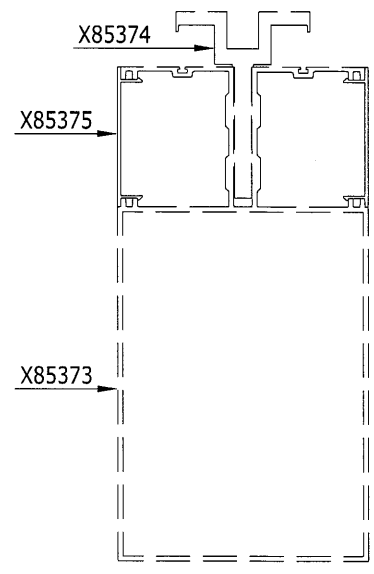

V.F

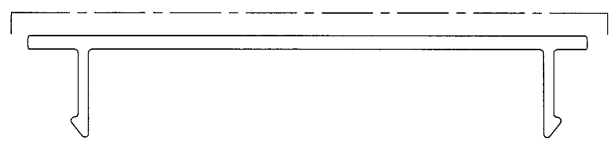

*所有壁厚只接受正公差

SIGNATURE GRADEING	HIGH SIGNATURE GRADEING	C.C.DIA(MM)							
AREA (SQ MM)	207.29	UNSPECIFIED THICKNESS	-	PERIMETER (MM)	221.23	STANDARD		SCALE	1:1
MASS (KG/M)	0.561	UNSPECIFIED CORNERS	-	SURFACE AREA	84.04	ALLOY	6063-T5	VERSION	
COMPANY ISSUE			DRAWN	XIA	DATE	16.09.30	APELLATION	-	PAGE OF
			STANDARDIZATION		DATE				
			TO SIGN		DATE				
			AUDITING		DATE				
MARKER	MODIFY FILE NO	SIGNATURE	DATE	APPROV		DATE			

11

CUSTOMER	CUSTOMER APPROVAL	CUST PART NO.	X85376
		SECTION NO.	

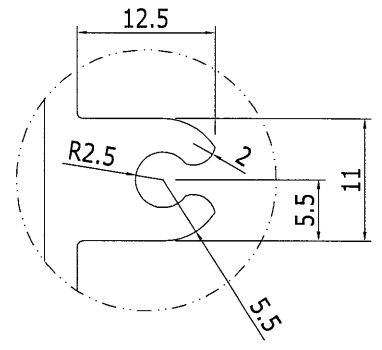
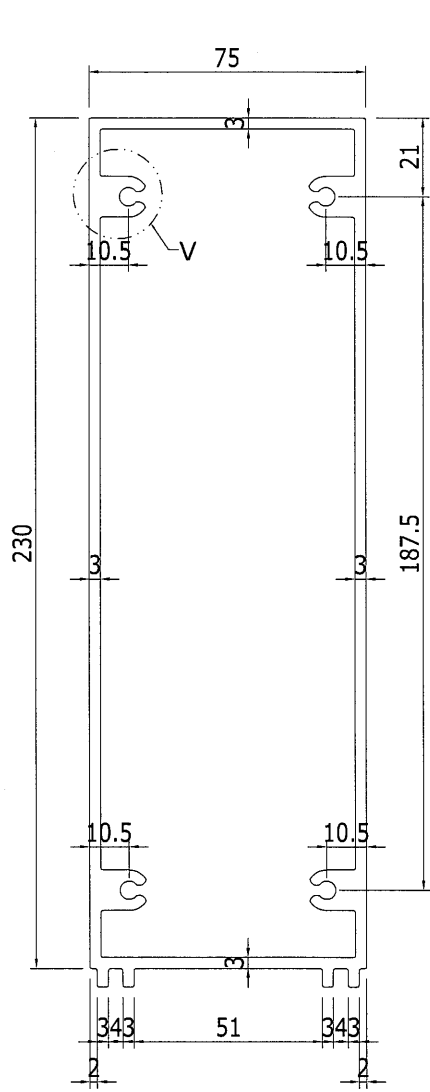

DETAIL "V" 3:1

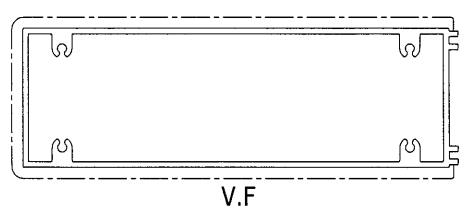

美特鋁質有限公司	
承認圖面	<i>[Signature]</i>
日期	2/20/16

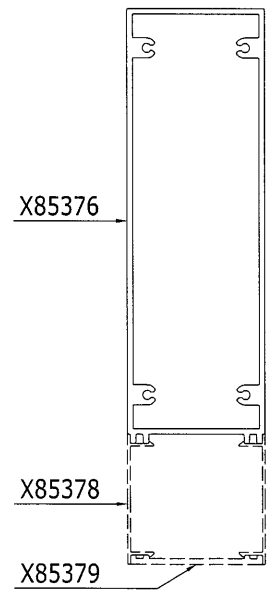

SIGNATURE GRADEING	HIGH SIGNATURE GRADEING	C.C.DIA(MM)	*所有壁厚只接受正公差						
AREA (SQ MM)	2262.35	UNSPECIFIED THICKNESS	-	PERIMETER (MM)	1369.05	STANDARD		SCALE	1:1
MASS (KG/M)	6.13	UNSPECIFIED CORNERS	-	SURFACE AREA	537.51	ALLOY	6063-T6	VERSION	
COMPANY ISSUE			DRAWN	XIA	DATE	16.09.30	APPELLATION	-	PAGE OF
			STANDARDIZATION		DATE				
			TO SIGN		DATE				
			AUDITING		DATE				
MARKER	MODIFY FILE NO	SIGNATURE	DATE	APPROV		DATE			

CUSTOMER	CUSTOMER APPROVAL	CUST PART NO.	X85377
		SECTION NO.	

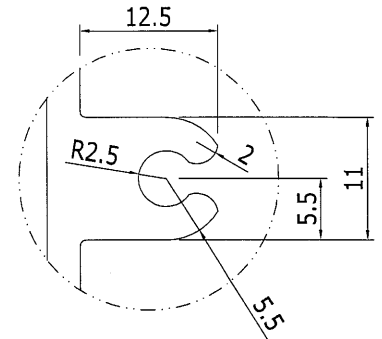
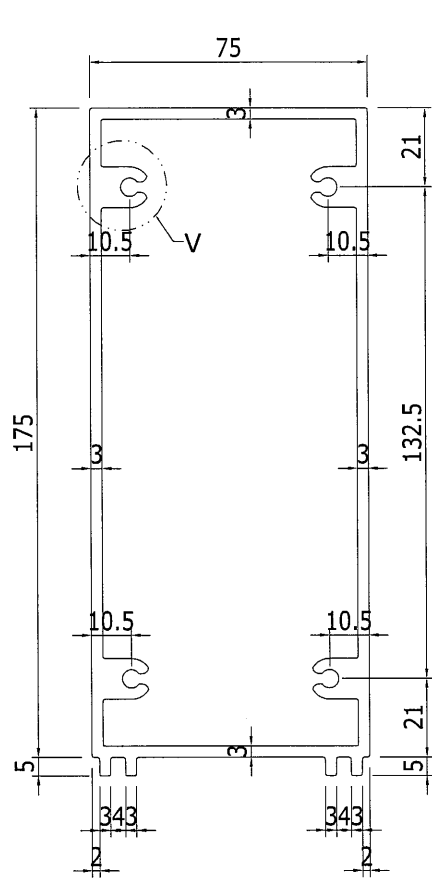

DETAIL "V" 3:1

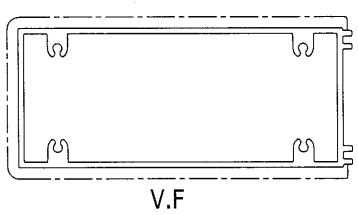

美特鋁質有限公司	
承認圖面	<i>[Signature]</i>
日期	2/10/16

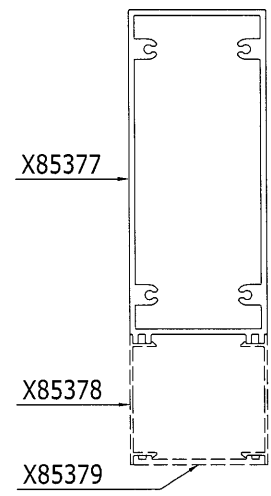

*所有壁厚只接受正公差

SIGNATURE GRADEING	HIGH SIGNATURE GRADEING	C.C.DIA(MM)		*所有壁厚只接受正公差					
AREA (SQ MM)	1932.35	UNSPECIFIED THICKNESS	-	PERIMETER (MM)	1149.05	STANDARD		SCALE	1:1
MASS (KG/M)	5.236	UNSPECIFIED CORNERS	-	SURFACE AREA	425.94	ALLOY	6063-T6	VERSION	
COMPANY ISSUE			DRAWN	XIA	DATE	16.09.30	APPELLATION	-	PAGE OF
			STANDARDIZATION		DATE				
			TO SIGN		DATE				
			AUDITING		DATE				
MARKER	MODIFY FILE NO	SIGNATURE	DATE	APPROV		DATE			

CUSTOMER	CUSTOMER APPROVAL	CUST PART NO.	X85378
		SECTION NO.	

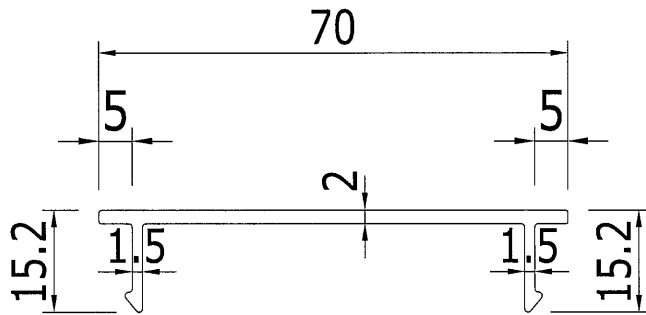

美特鋁質有限公司	
承認圖面	<i>[Signature]</i>
日期	2/10/16

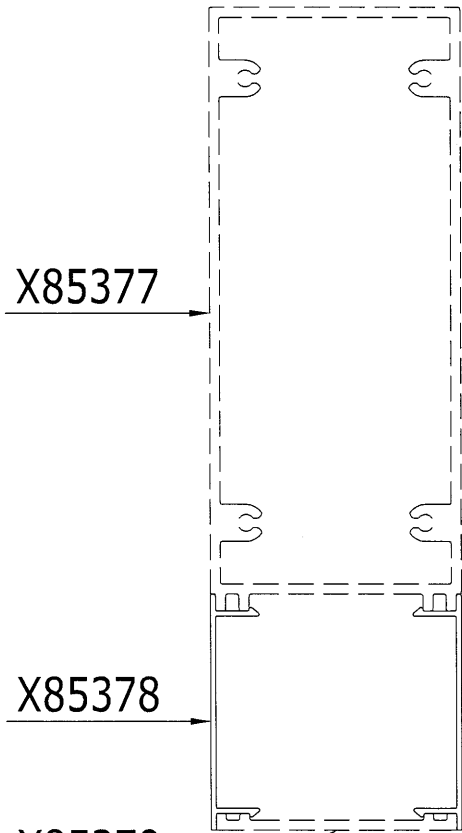

V.F

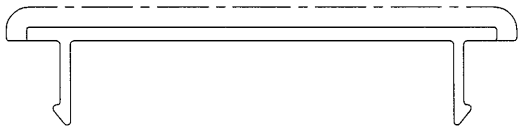

*所有壁厚只接受正公差

SIGNATURE GRADEING	HIGH SIGNATURE GRADEING	C.C.DIA(MM)							
AREA (SQ MM)	182.09	UNSPECIFIED THICKNESS	-	PERIMETER (MM)	196.23	STANDARD		SCALE	1:1
MASS (KG/M)	0.493	UNSPECIFIED CORNERS	-	SURFACE AREA	73.18	ALLOY	6063-T5	VERSION	
COMPANY ISSUE			DRAWN	XIA	DATE	16.09.30	APPELLATION	-	PAGE OF
			STANDARDIZATION		DATE				
			TO SIGN		DATE				
			AUDITING		DATE				
MARKER	MODIFY FILE NO	SIGNATURE	DATE	APPROV		DATE			

16

CUSTOMER		CUSTOMER APPROVAL		CUST PART NO.	X85379
				SECTION NO.	

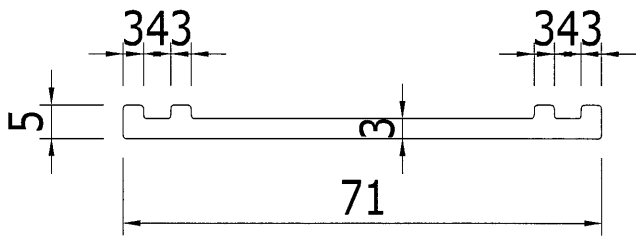

美特鋁質有限公司	
承認圖面	<i>[Signature]</i>
日期	3/10/16

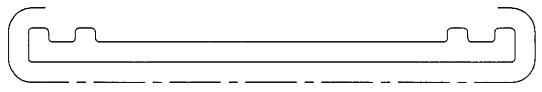
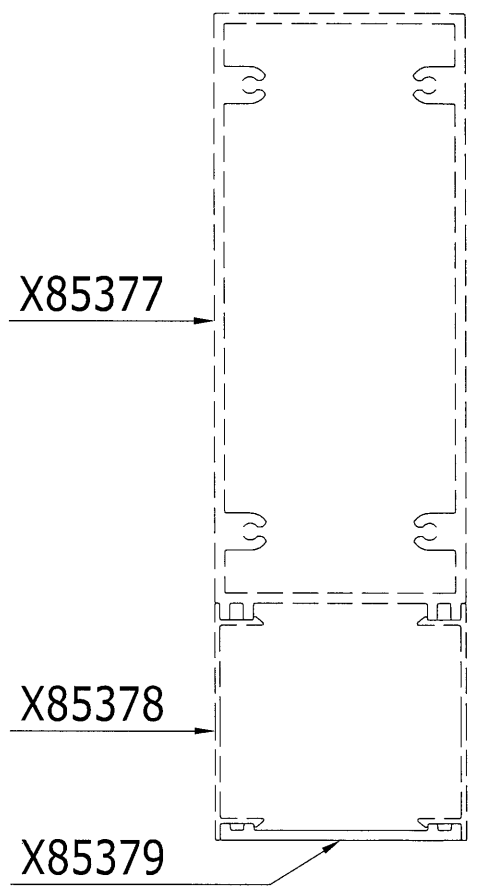

V.F

*所有壁厚只接受正公差

SIGNATURE GRADEING	HIGH SIGNATURE GRADEING	C.C.DIA(MM)							
AREA (SQ MM)	236.78	UNSPECIFIED THICKNESS	-	PERIMETER (MM)	160.56	STANDARD		SCALE	1:1
MASS (KG/M)	0.641	UNSPECIFIED CORNERS	-	SURFACE AREA	87.71	ALLOY	6063-T5	VERSION	
COMPANY ISSUE			DRAWA	XIA	DATE	16.09.30	APELLATION	-	PAGE OF
			STANDA-RDIZATION		DATE				
			TO SIGN		DATE				
			AUDITING		DATE				
MARKER	MODIFY FILE NO	SIGNATURE	DATE	APPROV	DATE				

15

CUSTOMER	CUSTOMER APPROVAL	CUST PART NO.	X85380
		SECTION NO.	

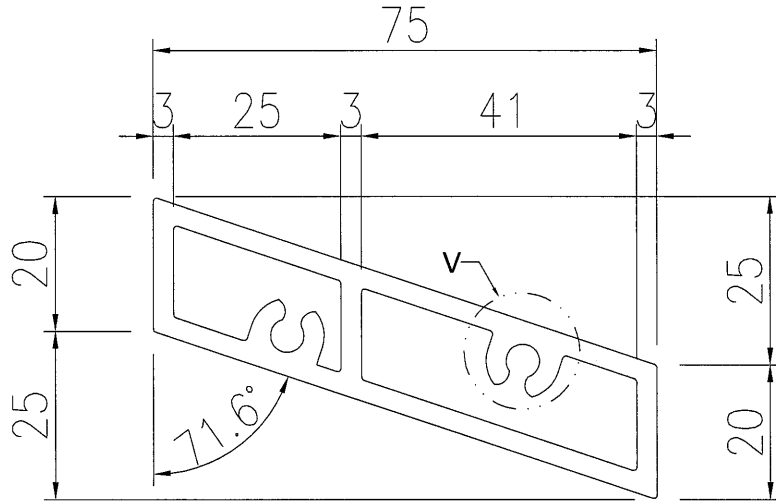

美特鋁質有限公司	
承認圖面	<i>[Signature]</i>
日期	2/10/16

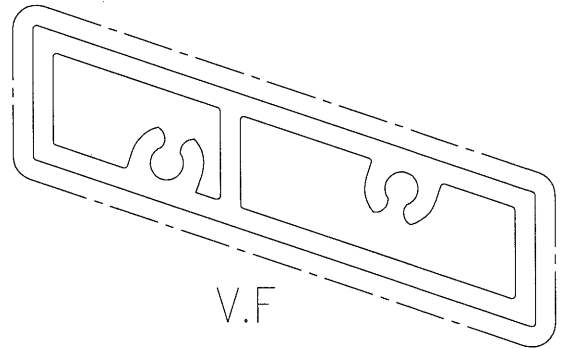
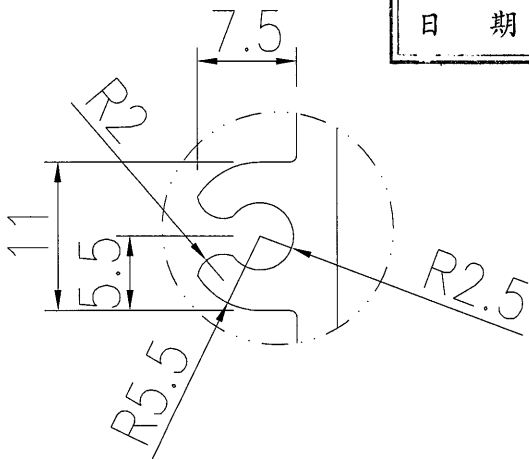

DETAIL "V" 2:1

*所有壁厚只接受正公差

SIGNATURE GRADEING	HIGH SIGNATURE GRADEING	C.C.DIA(MM)							
AREA (SQ MM)	692.11	UNSPECIFIED THICKNESS	-	PERIMETER (MM)	438.25	STANDARD		SCALE	1:1
MASS (KG/M)	1.875	UNSPECIFIED CORNERS	-	SURFACE AREA	197.03	ALLOY	6063-T6	VERSION	
COMPANY ISSUE			DRAWN	XIA	DATE	16.09.30	APELLATION	-	PAGE OF
			STANDARDIZATION		DATE		 美特鋁質有限公司 MIDI Aluminium Fabricator Ltd.		
			TO SIGN		DATE				
			AUDITING		DATE				
MARKER	MODIFY FILE NO	SIGNATURE	DATE	APPROV		DATE			

CUSTOMER		CUSTOMER APPROVAL		CUST PART NO.	X85381
				SECTION NO.	

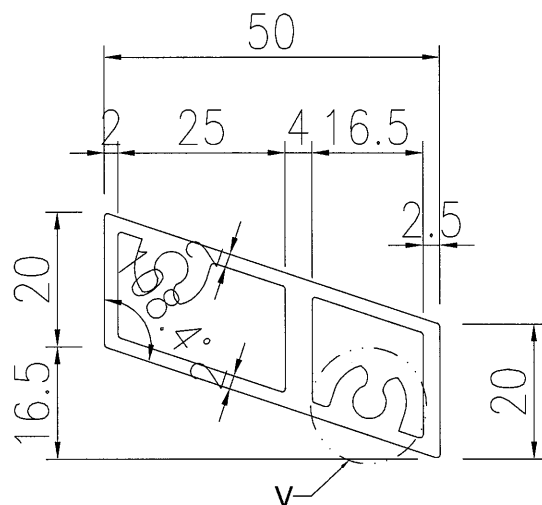

美特鋁質有限公司	
承認圖面	<i>[Signature]</i>
日期	2/10/16

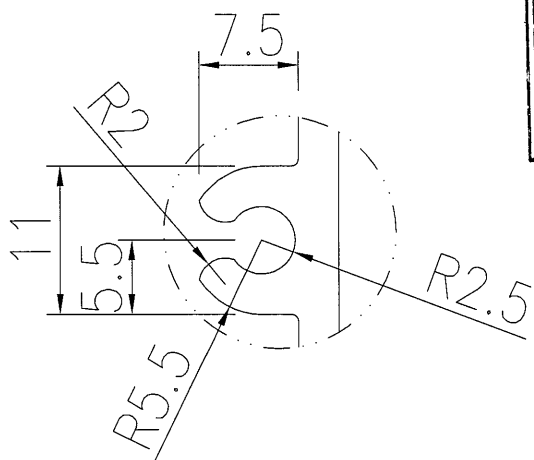

DETAIL "V" 2:1

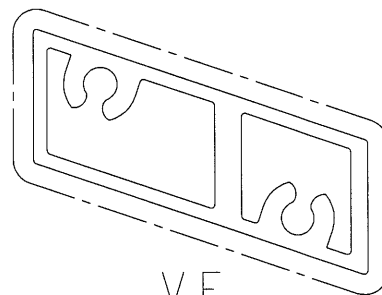

V.F

SIGNATURE GRADEING	HIGH SIGNATURE GRADEING	C.C.DIA(MM)							
AREA (SQ MM)	439.61	UNSPECIFIED THICKNESS	-	PERIMETER (MM)	342.54	STANDARD		SCALE	1:1
MASS (KG/M)	1.191	UNSPECIFIED CORNERS	-	SURFACE AREA	144.33	ALLOY	6063-T6	VERSION	
COMPANY ISSUE			DRAWN	XIA	DATE	16.09.30	APPELLATION	-	PAGE OF
			STANDARDIZATION		DATE				
			TO SIGN		DATE				
			AUDITING		DATE				
MARKER	MODIFY FILE NO	SIGNATURE	DATE	APPROV	DATE				

CUSTOMER		CUSTOMER APPROVAL		CUST PART NO.	X85382
				SECTION NO.	

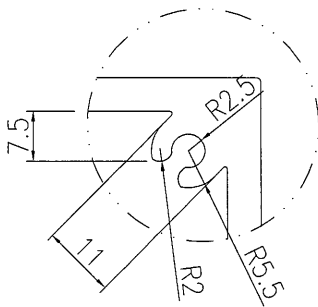
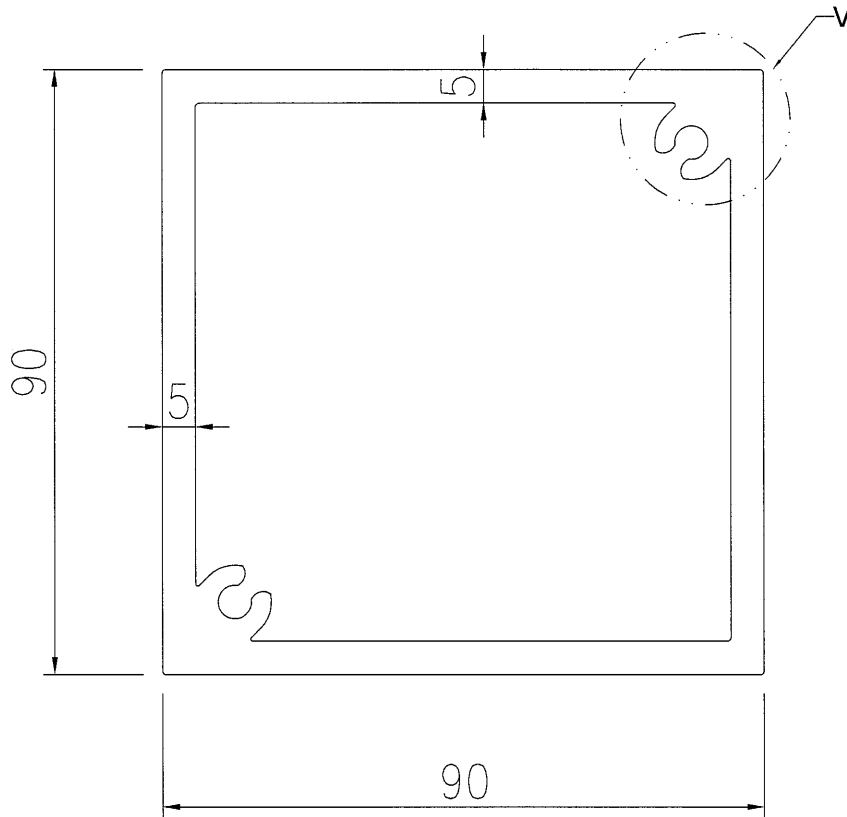

DETAIL "V"

美特鋁質有限公司	
承認圖面	<i>[Signature]</i>
日期	3/20/16

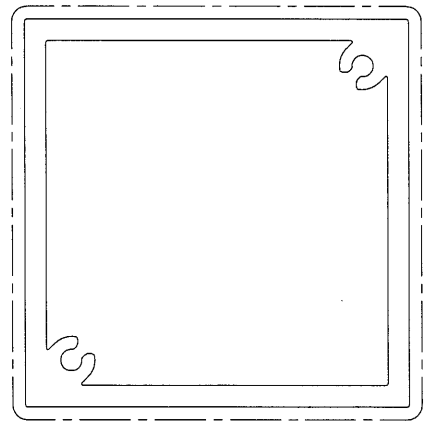

*所有壁厚只接受正公差 V.F

SIGNATURE GRADEING	HIGH SIGNATURE GRADEING	C.C.DIA(MM)		*所有壁厚只接受正公差				V.F	
AREA (SQ MM)	1855.10	UNSPECIFIED THICKNESS	-	PERIMETER (MM)	716.79	STANDARD		SCALE	1:1
MASS (KG/M)	5.027	UNSPECIFIED CORNERS	-	SURFACE AREA	359.14	ALLOY	6063-T6	VERSION	
COMPANY ISSUE			DRAWN	XIA	DATE	16.09.30	APPELLATION	-	PAGE OF
			STANDARDIZATION		DATE		 美特鋁質有限公司 MIDI Aluminium Fabricator Ltd.		
			TO SIGN		DATE				
			AUDITING		DATE				
MARKER	MODIFY FILE NO	SIGNATURE	DATE	APPROV	DATE				

CUSTOMER		CUSTOMER APPROVAL		CUST PART NO.	X85383
				SECTION NO.	

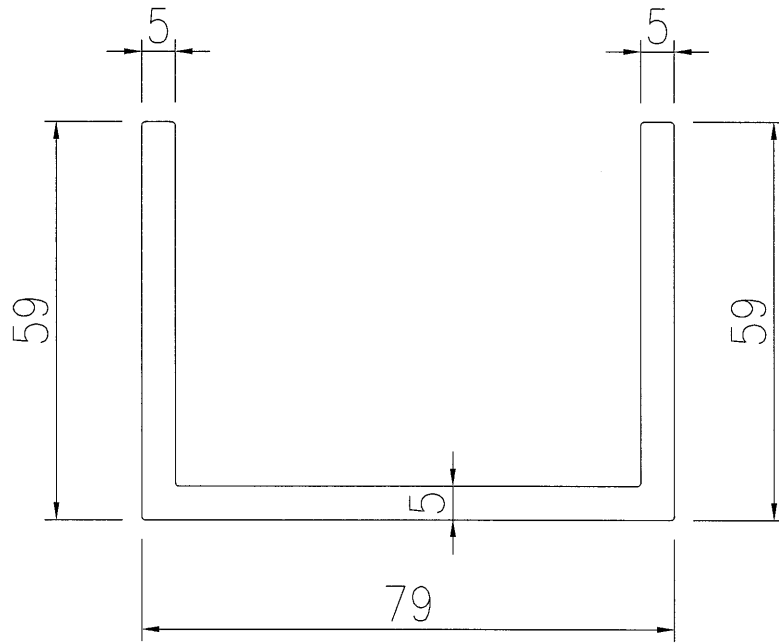

美特鋁質有限公司	
承認圖面	<i>[Signature]</i>
日期	2/10/16

*所有壁厚只接受正公差

SIGNATURE GRADEING	HIGH SIGNATURE GRADEING	C.C.DIA(MM)							
AREA (SQ MM)	934.78	UNSPECIFIED THICKNESS	-	PERIMETER (MM)	382.28	STANDARD		SCALE	1:1
MASS (KG/M)	2.533	UNSPECIFIED CORNERS	-	SURFACE AREA	-	ALLOY	6061-T6	VERSION	
COMPANY ISSUE			DRAWN	XIA	DATE	16.09.30	APPELLATION	-	PAGE OF
			STANDARDIZATION		DATE		 美特鋁質有限公司 MIDI Aluminium Fabricator Ltd.		
			TO SIGN		DATE				
			AUDITING		DATE				
MARKER	MODIFY FILE NO	SIGNATURE	DATE	APPROV	DATE				

CUSTOMER	CUSTOMER APPROVAL	CUST PART NO.	X85385
		SECTION NO.	

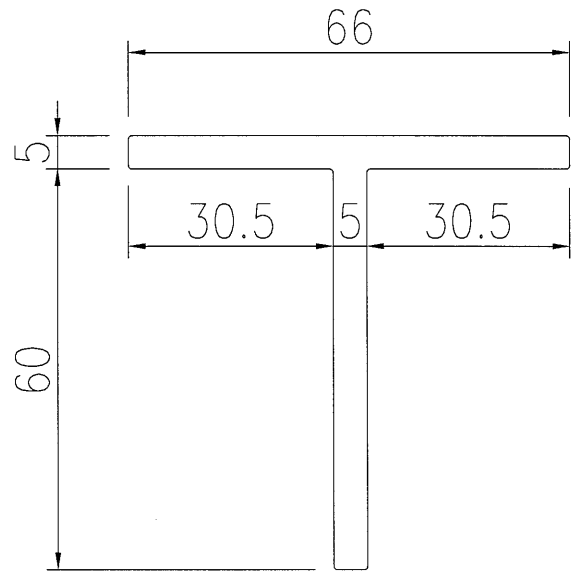

美特鋁質有限公司	
承認圖面	<i>[Signature]</i>
日期	2/10/16

*所有壁厚只接受正公差

SIGNATURE GRADEING	HIGH SIGNATURE GRADEING	C.C.DIA(MM)							
AREA (SQ MM)	629.18	UNSPECIFIED THICKNESS	-	PERIMETER (MM)	260.04	STANDARD		SCALE	1:1
MASS (KG/M)	1.705	UNSPECIFIED CORNERS	-	SURFACE AREA	-	ALLOY	6061-T6	VERSION	
COMPANY ISSUE			DRAWN	XIA	DATE	16.09.30	APPELLATION	-	PAGE OF
			STANDARDIZATION		DATE		 美特鋁質有限公司 MIDI Aluminium Fabricator Ltd.		
			TO SIGN		DATE				
			AUDITING		DATE				
MARKER	MODIFY FILE NO	SIGNATURE	DATE	APPROV	DATE				

CUSTOMER		CUSTOMER APPROVAL		CUST PART NO.	X85386
				SECTION NO.	

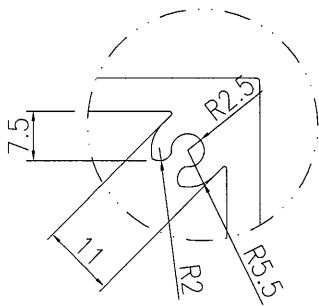
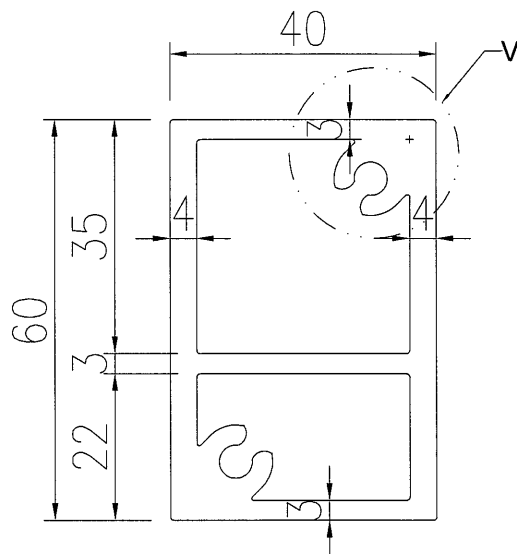

DETAIL "V"

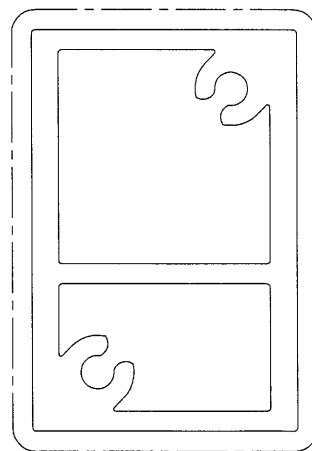
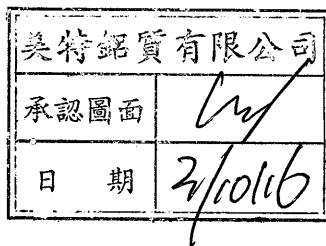

V.F

*所有壁厚只接受正公差

SIGNATURE GRADEING	HIGH SIGNATURE GRADEING	C.C.DIA(MM)							
AREA (SQ MM)	923.31	UNSPECIFIED THICKNESS	-	PERIMETER (MM)	465.93	STANDARD		SCALE	1:1
MASS (KG/M)	2.502	UNSPECIFIED CORNERS	-	SURFACE AREA	199.14	ALLOY	6063-T6	VERSION	
COMPANY ISSUE			DRAWA	XIA	DATE	16.09.30	APELLATION	-	PAGE OF
			STANDA-RDIZATION		DATE		 美特鋁質有限公司 MIDI Aluminium Fabricator Ltd.		
			TO SIGN		DATE				
			AUDITING		DATE				
MARKER	MODIFY FILE NO	SIGNATURE	DATE	APPROV	DATE				

CUSTOMER	CUSTOMER APPROVAL	CUST PART NO.	X85387
		SECTION NO.	

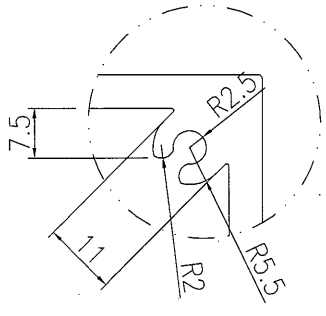
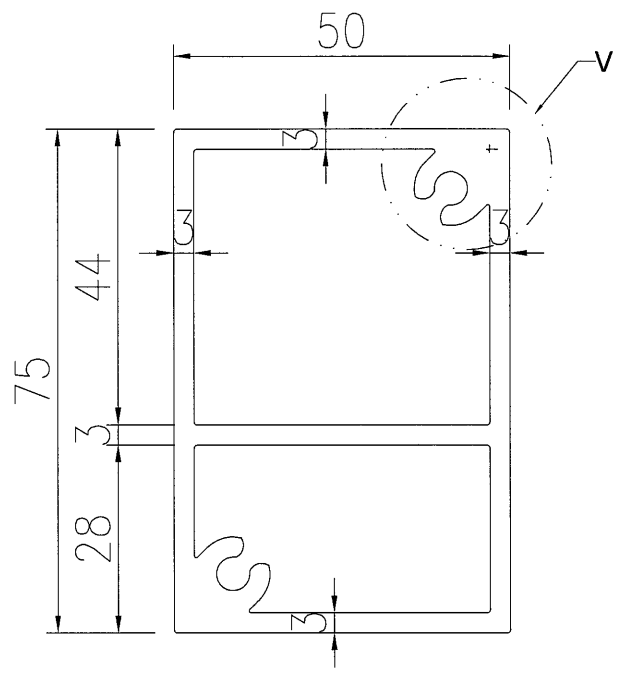

DETAIL "V"

美特鋁質有限公司	
承認圖面	<i>[Signature]</i>
日期	3/10/16

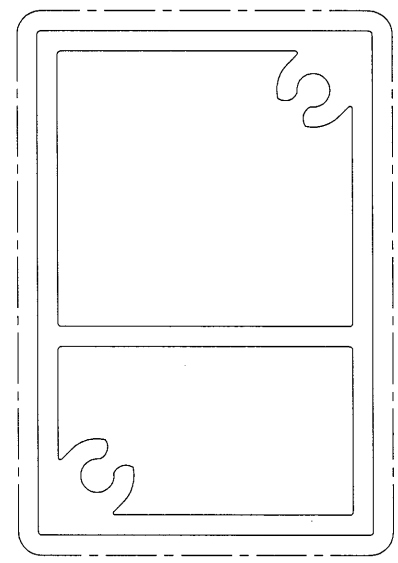

SIGNATURE GRADEING		HIGH SIGNATURE GRADEING	C.C.DIA(MM)	*所有壁厚只接受正公差				V.F	
AREA (SQ MM)	1003.39	UNSPECIFIED THICKNESS	-	PERIMETER (MM)	595.32	STANDARD		SCALE	1:1
MASS (KG/M)	2.719	UNSPECIFIED CORNERS	-	SURFACE AREA	249.60	ALLOY	6063-T6	VERSION	
COMPANY ISSUE			DRAWN	XIA	DATE	16.09.30	APPELLATION	-	PAGE OF
			STANDARDIZATION		DATE		美特鋁質有限公司 MIDI Aluminium Fabricator Ltd.		
			TO SIGN		DATE				
			AUDITING		DATE				
MARKER	MODIFY FILE NO	SIGNATURE	DATE	APPROV		DATE			

22

CUSTOMER		CUSTOMER APPROVAL		CUST PART NO.	X85388
				SECTION NO.	

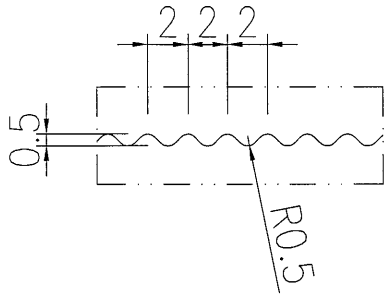

DETAIL "V" 3:1

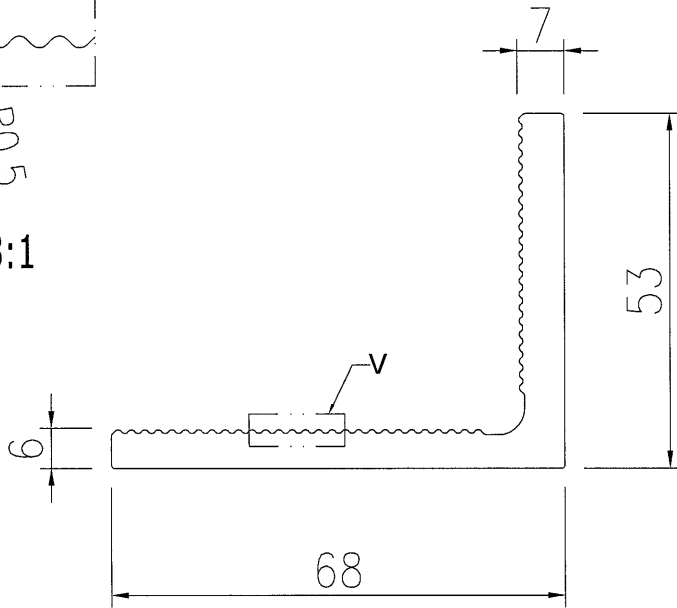

美特鋁質有限公司	
承認圖面	<i>Cxy</i>
日期	3/10/16

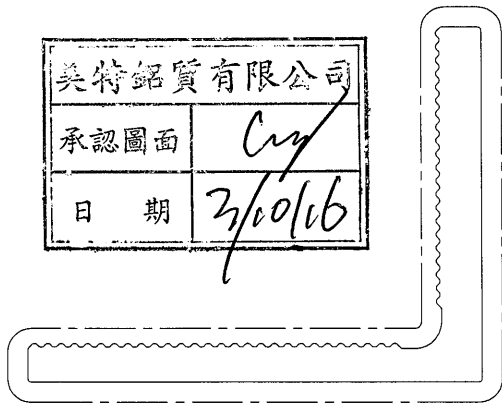

V.F

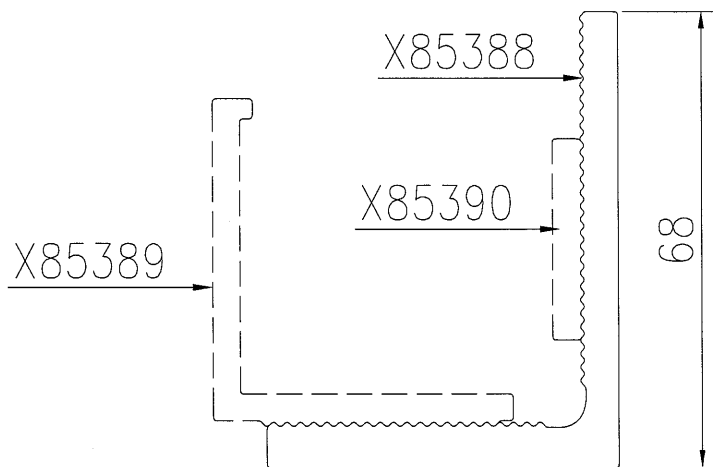

*所有壁厚只接受正公差

SIGNATURE GRADEING	HIGH SIGNATURE GRADEING	C.C.DIA(MM)							
AREA (SQ MM)	679.96	UNSPECIFIED THICKNESS	-	PERIMETER (MM)	259.49	STANDARD		SCALE	1:1
MASS (KG/M)	1.843	UNSPECIFIED CORNERS	-	SURFACE AREA	259.49	ALLOY	6061-T6	VERSION	
COMPANY ISSUE			DRAWN	XIA	DATE	16.09.30	APPELLATION	-	PAGE OF
			STANDARDIZATION		DATE				
			TO SIGN		DATE				
			AUDITING		DATE				
MARKER	MODIFY FILE NO	SIGNATURE	DATE	APPROV	DATE				

23

CUSTOMER	CUSTOMER APPROVAL	CUST PART NO.	X85389
		SECTION NO.	

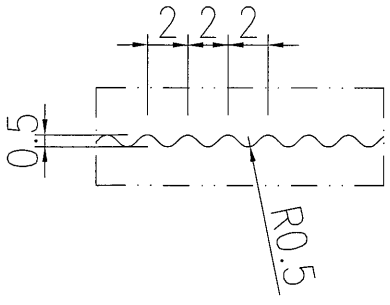

DETAIL "V" 3:1

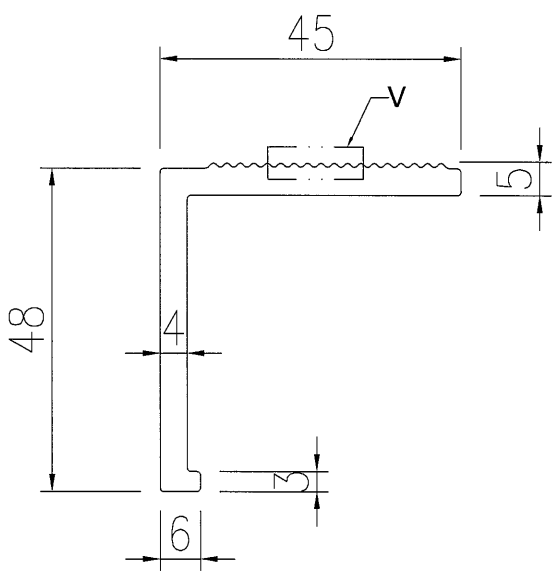

美特鋁質有限公司	
承認圖面	<i>[Signature]</i>
日期	3/10/16

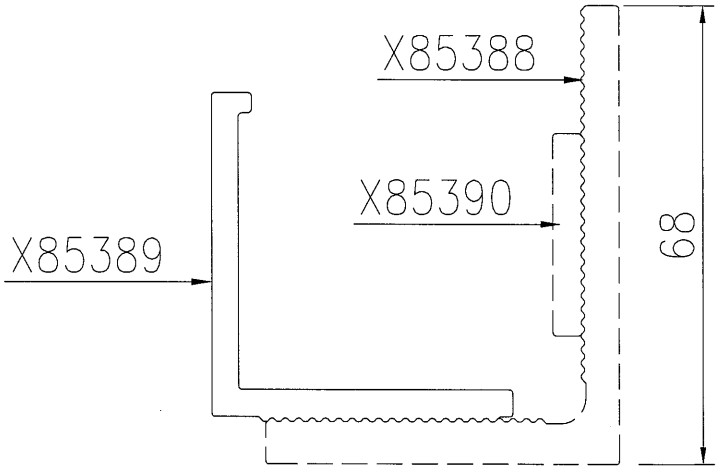
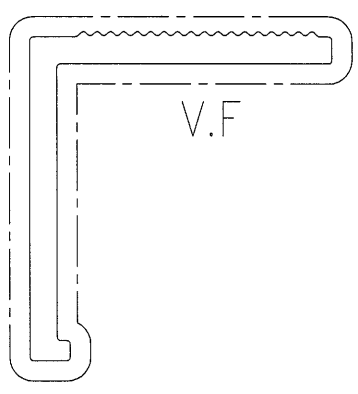

*所有壁厚只接受正公差

SIGNATURE GRADEING	HIGH SIGNATURE GRADEING	C.C.DIA(MM)	*所有壁厚只接受正公差						
AREA (SQ MM)	380.97	UNSPECIFIED THICKNESS	-	PERIMETER (MM)	195.58	STANDARD		SCALE	1:1
MASS (KG/M)	1.032	UNSPECIFIED CORNERS	-	SURFACE AREA	195.58	ALLOY	6063-T6	VERSION	
COMPANY ISSUE			DRAWN	XIA	DATE	16.09.30	APPELLATION	-	PAGE OF
			STANDARDIZATION		DATE				
			TO SIGN		DATE				
			AUDITING		DATE				
MARKER	MODIFY FILE NO	SIGNATURE	DATE	APPROV		DATE			

CUSTOMER	CUSTOMER APPROVAL	CUST PART NO.	X85392
		SECTION NO.	

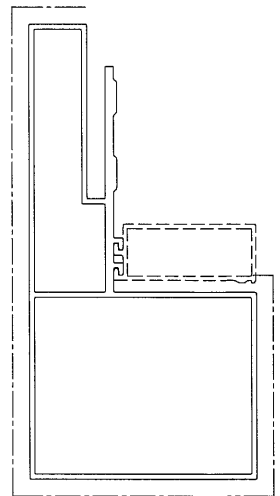
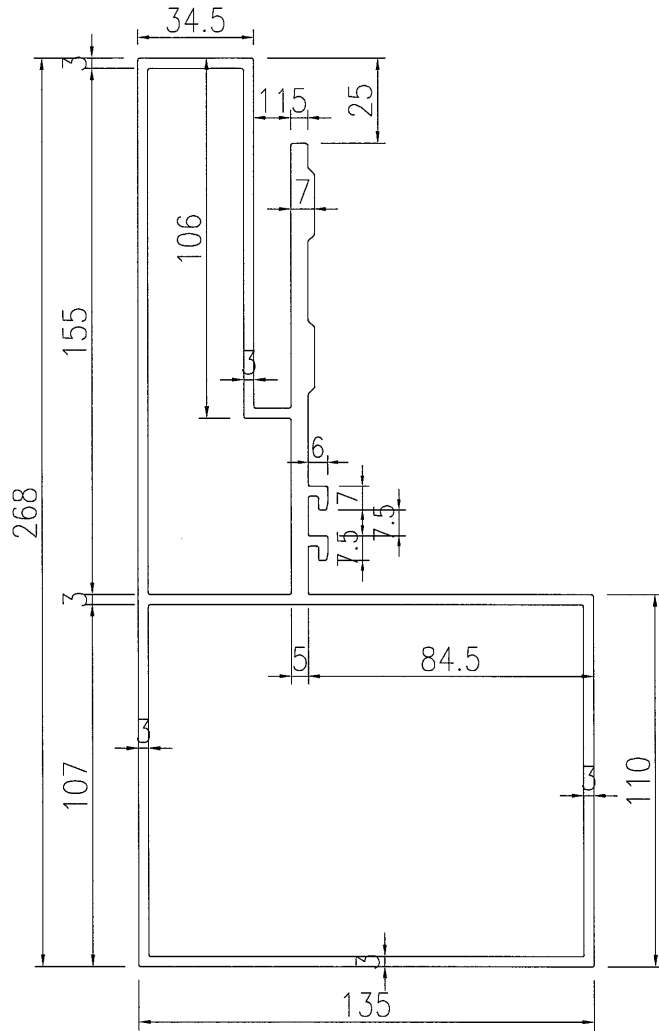

美特鋁質有限公司	
承認圖面	<i>[Signature]</i>
日期	2/10/16

*所有壁厚只接受正公差

SIGNATURE GRADEING	HIGH SIGNATURE GRADEING	C.C.DIA(MM)							
AREA (SQ.MM)	3145.72	UNSPECIFIED THICKNESS	-	PERIMETER (MM)	1858.67	STANDARD		SCALE	1:1
MASS (KG/M)	8.525	UNSPECIFIED CORNERS	-	SURFACE AREA	547.22	ALLOY	6063-T6	VERSION	
COMPANY ISSUE			DRAWN	XIA	DATE	16.09.30	APPELLATION	-	PAGE OF
			STANDARDIZATION		DATE				
			TO SIGN		DATE				
			AUDITING		DATE				
MARKER	MODIFY FILE NO	SIGNATURE	DATE	APPROV		DATE			

25

CUSTOMER	CUSTOMER APPROVAL	CUST PART NO.	X85393
		SECTION NO.	

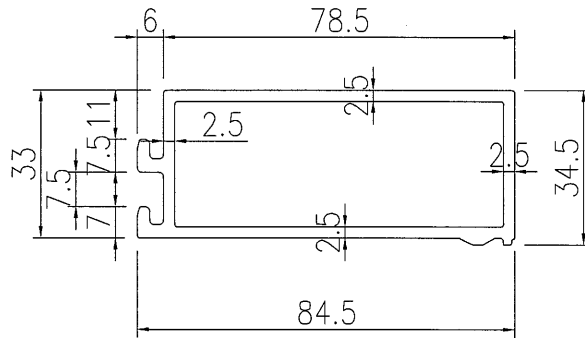

美特鋁質有限公司	
承認圖面	<i>[Signature]</i>
日期	2/10/16

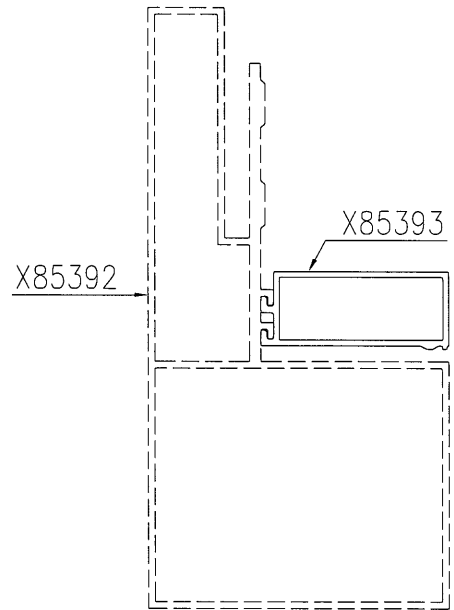
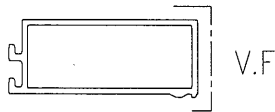

SIGNATURE GRADEING	HIGH SIGNATURE GRADEING	C.C.DIA(MM)	*所有壁厚只接受正公差						
AREA (SQ MM)	601.77	UNSPECIFIED THICKNESS	-	PERIMETER (MM)	463.43	STANDARD		SCALE	1:1
MASS (KG/M)	1.631	UNSPECIFIED CORNERS	-	SURFACE AREA	65.25	ALLOY	6063-T6	VERSION	
COMPANY ISSUE			DRAWN	XIA	DATE	16.09.30	APPELLATION	-	PAGE OF
			STANDARDIZATION		DATE				
			TO SIGN		DATE				
			AUDITING		DATE				
MARKER	MODIFY FILE NO	SIGNATURE	DATE	APPROV		DATE			

26

CUSTOMER	CUSTOMER APPROVAL	CUST PART NO.	X85394
		SECTION NO.	

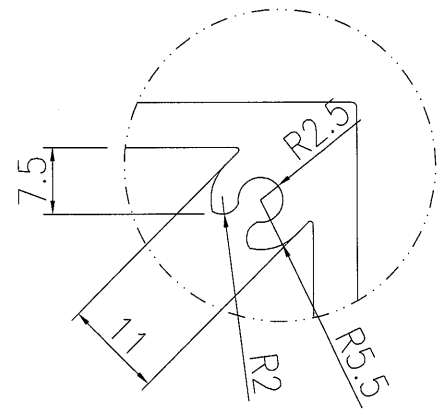
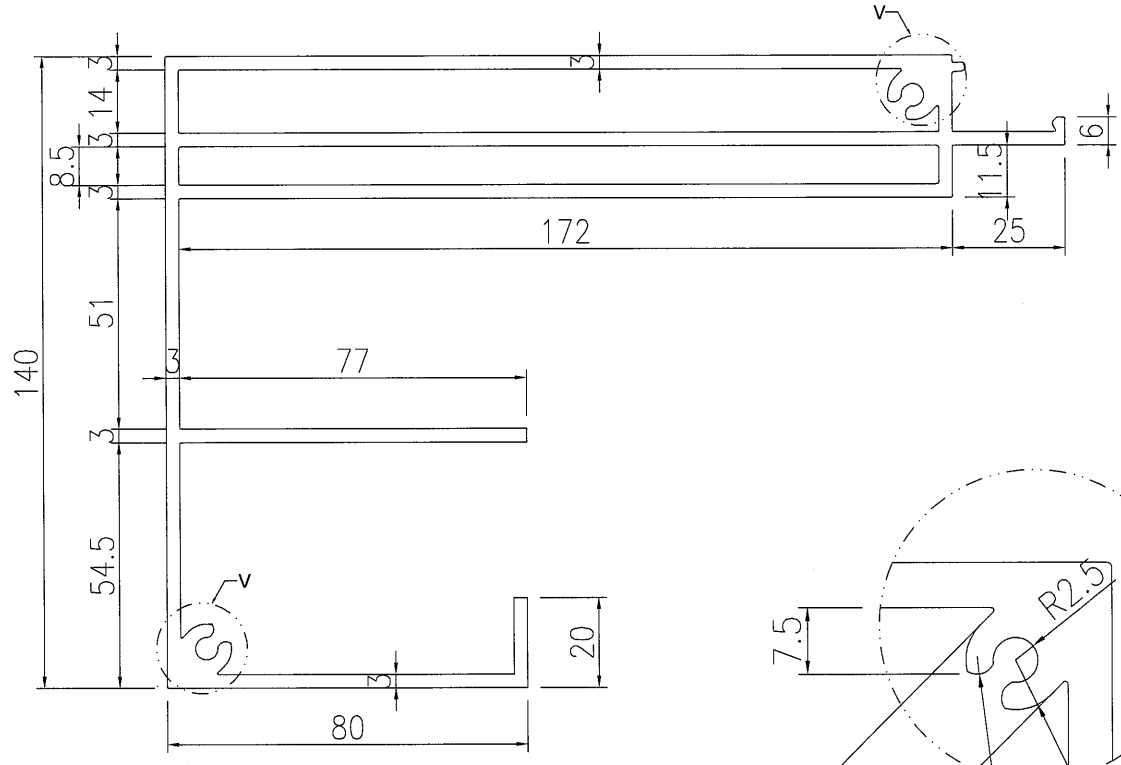

DETAIL "V" 2:1

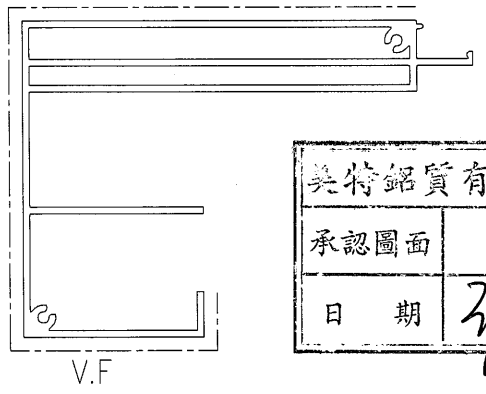

美特鋁質有限公司
承認圖面
日期 2/10/16

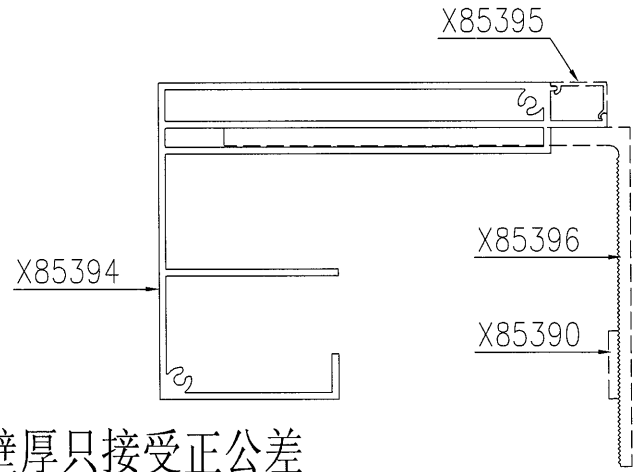

*所有壁厚只接受正公差

SIGNATURE GRADEING	HIGH SIGNATURE GRADEING	C.C.DIA(MM)							
AREA (SQ MM)	2792.30	UNSPECIFIED THICKNESS	-	PERIMETER (MM)	1789.87	STANDARD		SCALE	1:1
MASS (KG/M)	7.567	UNSPECIFIED CORNERS	-	SURFACE AREA	414.91	ALLOY	6063-T6	VERSION	
COMPANY ISSUE			DRAWA	XIA	DATE	16.09.30	APPELLATION	-	PAGE OF
			STANDA-RDIZATION		DATE				
			TO SIGN		DATE				
			AUDITING		DATE				
MARKER	MODIFY FILE NO	SIGNATURE	DATE	APPROV		DATE			

CUSTOMER	CUSTOMER APPROVAL	CUST PART NO.	X85395
		SECTION NO.	

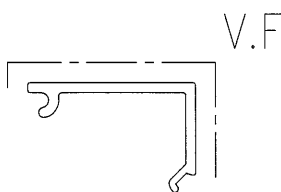
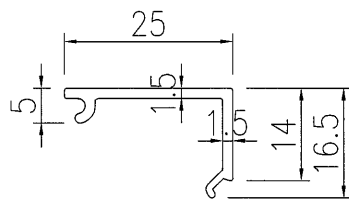

美特鋁質有限公司	
承認圖面	<i>ly</i>
日期	2/2016

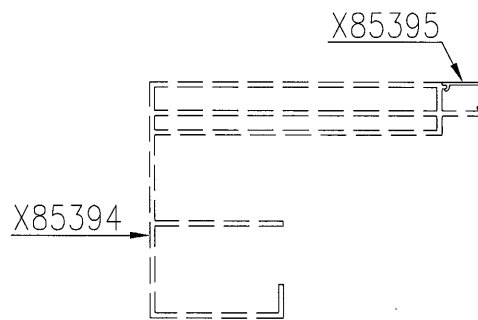

*所有壁厚只接受正公差

SIGNATURE GRADEING	HIGH SIGNATURE GRADEING	C.C.DIA(MM)							
AREA (SQ MM)	66.61	UNSPECIFIED THICKNESS	-	PERIMETER (MM)	92.24	STANDARD	SCALE	1:1	
MASS (KG/M)	0.181	UNSPECIFIED CORNERS	-	SURFACE AREA	40.42	ALLOY	6063-T5	VERSION	
COMPANY ISSUE			DRAWN	XIA	DATE	16.09.30	APPELLATION	-	PAGE OF
			STANDARDIZATION		DATE		美特鋁質有限公司 MIDI Aluminium Fabricator Ltd.		
			TO SIGN		DATE				
			AUDITING		DATE				
MARKER	MODIFY FILE NO	SIGNATURE	DATE	APPROV	DATE				

28

CUSTOMER	CUSTOMER APPROVAL	CUST PART NO.	X85396
		SECTION NO.	

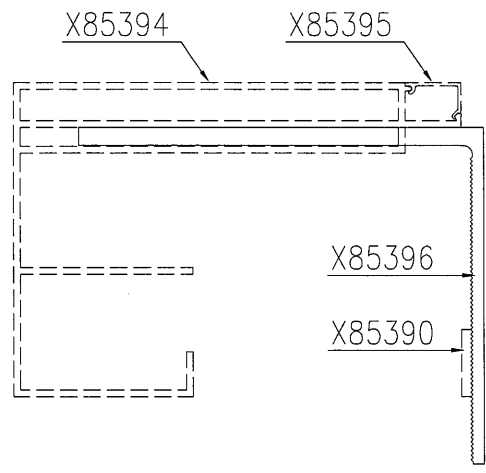
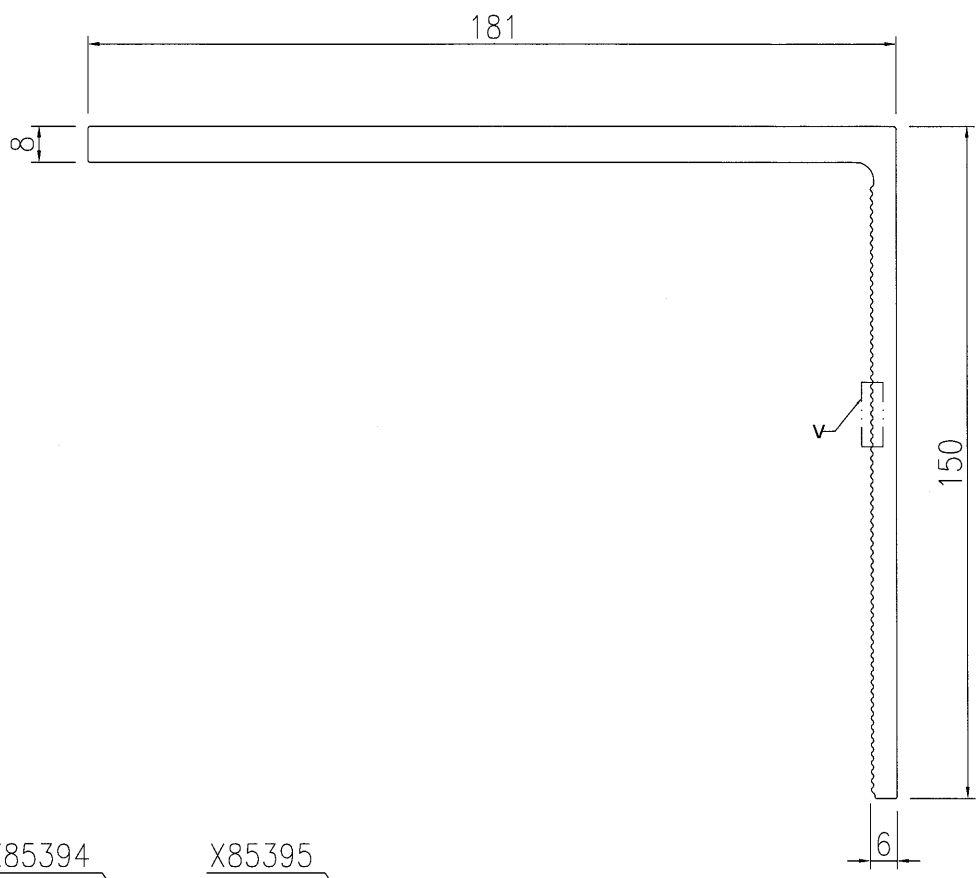

美特鋁質有限公司	
承認圖面	<i>[Signature]</i>
日期	2/20/16

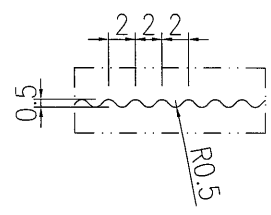

*所有壁厚只接受正公差

DETAIL "V" 3:1

SIGNATURE GRADEING	HIGH SIGNATURE GRADEING	C.C.DIA(MM)		*所有壁厚只接受正公差				DETAIL "V" 3:1	
AREA (SQ MM)	2229.12	UNSPECIFIED THICKNESS	-	PERIMETER (MM)	686.52	STANDARD		SCALE	1:1
MASS (KG/M)	6.041	UNSPECIFIED CORNERS	-	SURFACE AREA	-	ALLOY	6061-T6	VERSION	
COMPANY ISSUE			DRAWN	XIA	DATE	16.09.30	APPELLATION	-	PAGE OF
			STANDARDIZATION		DATE				
			TO SIGN		DATE				
			AUDITING		DATE				
MARKER	MODIFY FILE NO	SIGNATURE	DATE	APPROV		DATE			

28

CUSTOMER		CUSTOMER APPROVAL		CUST PART NO.	X85397
				SECTION NO.	

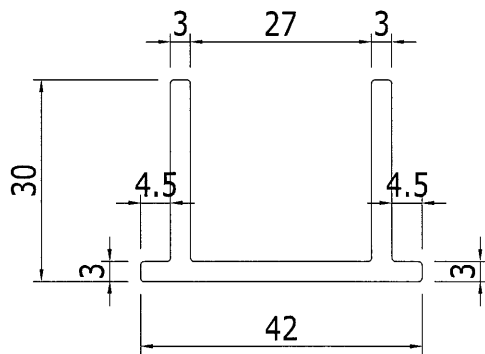

美特鋁質有限公司	
承認圖面	<i>Lu</i>
日期	3/10/16

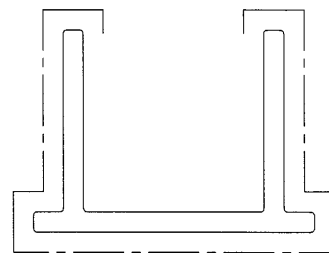

V.F

*所有壁厚只接受正公差

SIGNATURE GRADEING	HIGH SIGNATURE GRADEING	C.C.DIA(MM)							
AREA (SQ MM)	287.78	UNSPECIFIED THICKNESS	-	PERIMETER (MM)	195.42	STANDARD		SCALE	1:1
MASS (KG/M)	0.779	UNSPECIFIED CORNERS	-	SURFACE AREA	115.85	ALLOY	6063-T6	VERSION	
COMPANY ISSUE			DRAWN	XIA	DATE	16.09.30	APPELLATION	-	PAGE OF
			STANDARDIZATION		DATE		 美特鋁質有限公司 MIDI Aluminium Fabricator Ltd.		
			TO SIGN		DATE				
			AUDITING		DATE				
MARKER	MODIFY FILE NO	SIGNATURE	DATE	APPROV	DATE				